

MediaWorks

by Bill Engholm



Copyright
Paul William Engholm
ALL RIGHTS RESERVED

MediaWorks

by Bill Engholm



Copyright
Paul William Engholm
ALL RIGHTS RESERVED

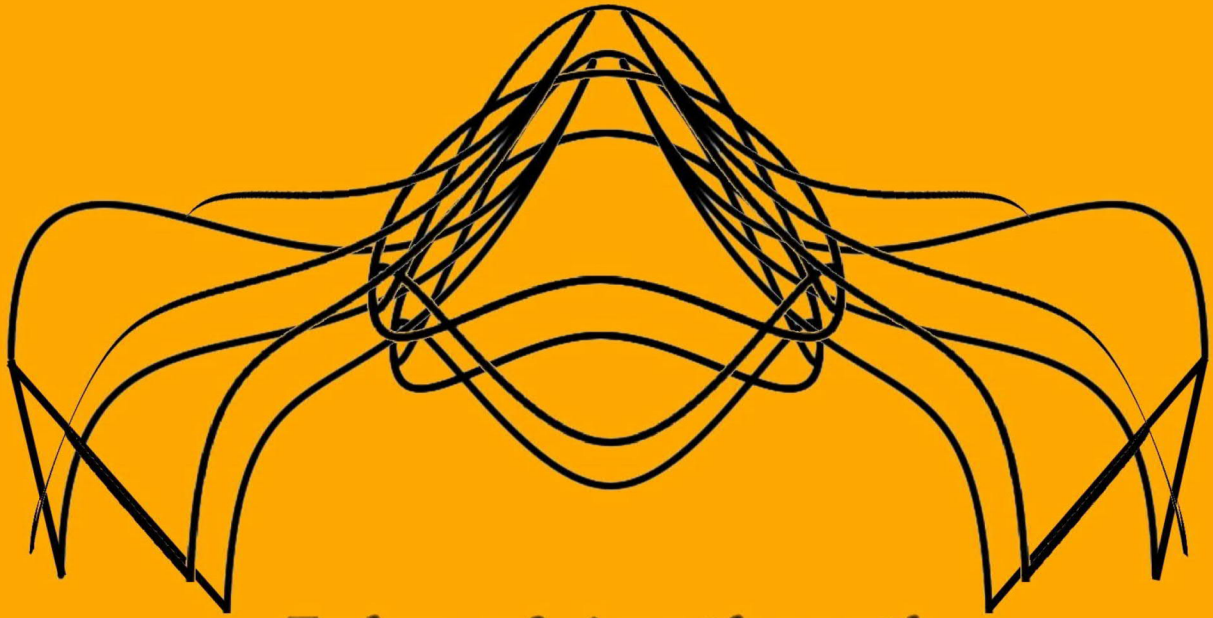

Tales of Anothearth
Folklore, Fables and Poetry
of the
Fictional Continent Anotherealm
and the Enchanted Isle

by Paul William Engholm

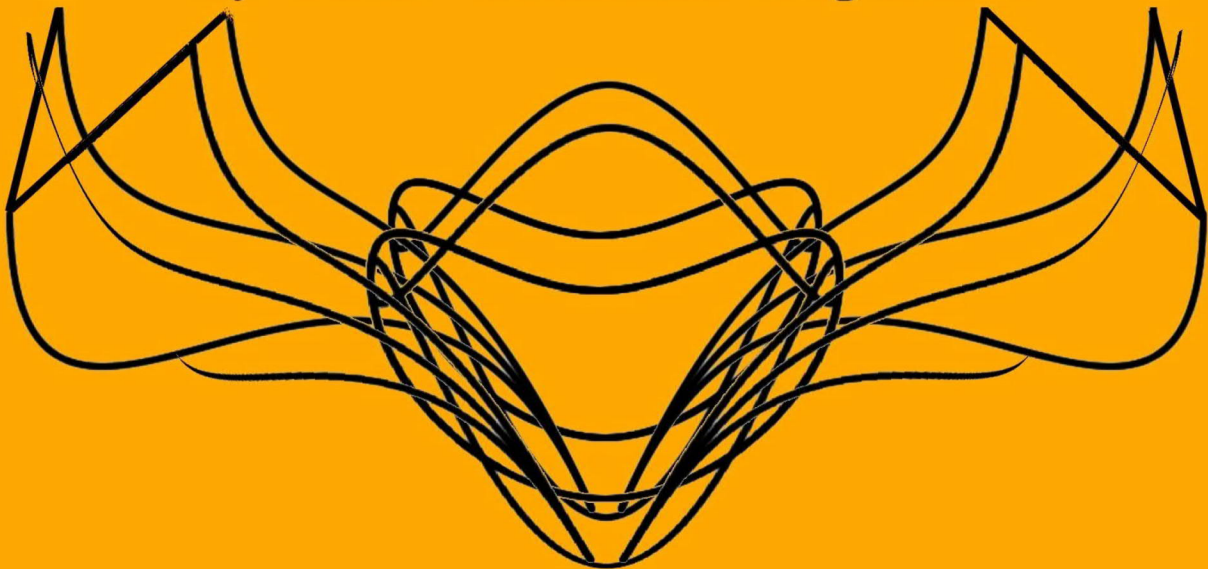

**Tales of Anothearth
Folklore, Fables and Poetry
of the
Fictional Continent Anotherealm
and the Enchanted Isle**

by Paul William Engholm



**Copyright Paul William Engholm
ALL RIGHTS RESERVED**

Introduction

The contents of Tales of Anothearth consist of fictional works based on a combination of folklore, myths and fables and additional original concepts of these same in unique combinations.

The name of the novel itself and some of the words used to give names to the fictional creatures and places used are a combination of words written and spoken as one word.

There is also the similarity of the last alphabetical letter of the first word being the same as the first alphabetical letter of the following word to form a single word by not using that same alphabetical letter twice, but only once. For example good + day would then be simply 'gooday' spelled with the letter 'd' appearing only once.

Part one of the novel entitled Anothearth Folklore is primarily an account of the Family Tree of the various life forms (floras and faunas) that inhabited the ancient fictional continent Anotherealm and the Enchanted Isle as they existed long ago in time and this section is depicted in chronological order.

Part two of the novel entitled Anothearth Fables contains a collection of short stories about the various creatures that inhabited these regions.

Part three of the novel entitled Anothearth Rhymes is poetry based primarily on the subject matter of the novel.

Table of Contents

Partial Glossary:

Unique Floras And Faunas

Unique Celestial Bodies

Part One: Anothearth Folklore

Part Two: Anothearth Fables

Sojourn Of The Dwarfs

The Fifty-Two Truths Of Folding And Unfolding

The Interpretation Of The Truths Of Folding And Unfolding

The Lady And The Tiny One

Legend Of Silverlark

The Adventures Of Azureone

Fable Of The Knight Of Toast

The Goblin And The Pixy

The Griffaera And The Wareacher

A Short History Of The Elves

The Oracle Of The Fountain

Mister Guessbox

Part Three: Anothearth Rhymes

Shine On Anotherealm

Pixy Rhyme

Elfinwarriors

Song Of Cyclops

Fable Of The Mermaids

DraquneWixaerd

The Smirk Of The Man In The Moon

Why The Man In The Moon Ran Too Soon

Saga Of Silverlark

The Tallest Of Trees

The Greatest Of All Continents

Captain Sea Eyes

The Wixaerd And The Draqune

The Wixaerd's Quest

Azureone

Mountowers Song

To Be Continued ...

... Supplemental ...

Partial Glossary:

Unique Floras And Faunas

Fish, Beast and Fowl of Groweed;
Pixies, Sprites and Fairies of Bulberry;
Nymphs of Watersweet;
Sylphs of Farmint;
Aborigines of Eartherb;
Dwarfs of Metaleaf;
Elves of Gemelon, Timelon and Realmelon;
Tiny Ones of Dewhisper;
Men Of Leafig;
Cyclopes of Earthorn;
The Oracle Of The Fountain of the Northern Faroot;
Draqunes of the Southeastern Fyroot;
the Griffaera, Man O'Saur, Harpettes, Gargoyles, Scorpio
and Tyrantula of the Knotree of the Watchorn root;
Mermaids of Waterroot;
Mermen of the Southwestern Fyroot;
Sirens of Waterhorn;
Trolls of Warmelon;
Goblins of Harmelon;
Gnomes of Weatherb;
the Gorgolyte of Growatch;
Phoenique of Fyrbush;
Women Of Leaflower;
Wagglers and Wareachers of Watcherb;
the Roc of Clawood;
Gryphons of Nightalon
and the Wixaerds of Hearthorn.

Unique Celestial Bodies

Aureleus The Starflower, Calistrophus The Starshell, Andromeles The Starace, Teleus The Eastar or Eastern Sun, Malispo The Wanestar or Doomoon and Galeus The Westar or Evenstar.

ANOTHEARTH FOLKLORE

In the dawn of time in another place, when the planet Anothearth was first formed out of the void, long before the light of the stars had even reached the planet the whole world was encompassed by the endless frozen waters of the ocean. The sky was completely dark at night and the only time there was any light was during the day when its Sun shone upon the face of the barren inhospitable planet. The planet was slightly more distant from its Sun than it is now for it had not settled into a permanent stable orbit and the climate was not suitable for sustaining life for as was stated the planet's surface was frozen.

Since it was at a greater distance from its Sun the Anothearth rotated more slowly on its own axis due to natural forces and there was little disturbance in its atmosphere and no clouds existed in the sky above. Anothearth was in its throes of birth then for the spark of life had not ignited upon the planet and it was in a state of dormancy. Eventually, as millennia passed by the Anothearth slowly wandered closer to its Sun due to its gravitational pull upon the planet and this in turn increased the speed of rotation of the Anothearth upon its axis.

This caused turbulence to occur such as volcanoes, for the core of the Anothearth itself was actually molten, earthquakes and storms arose, and the sea began to withdraw as the waters evaporated and dry land appeared. First, it was one great continent alone upon the face of the planet, greater than any existing today combined and this massive, foreboding body of land was named ... Anotherealm. For nearly a billion years, the continent heaved with volcanic eruptions and the smoke of the mountainous infernos filled the air. Then the crust of the planet upon which the molten seas flowed began slowly cooling. Most of the volcanoes became dormant and the sky began clearing.

Eventually, the inevitable happened and after a long time, there appeared the first, small living organism. Coincidentally at the same moment of this occurrence as if it was a sign, the light of the first star to reach Anothearth appeared that night and historians named the star Aureleus, which means Starflower. The beginning of life had formed upon the world and it was a plant that history tells us was given the name of Arborstar, that transliterates as ... Tree Of The Fruit Of Life.

For many millennia, the Arborstar grew until it was the most gigantic tree ever to have existed in all time. Upon this tree, all the limbs except one remained dormant and a limb that branched out of the lowest main Western bough of the trunk and grew in a generally vertical direction produced a variety of floras collectively named Groweed. They bloomed, the flowers became pollinated and the winds carried the seeds unto the far reaches of Anothearth, saturating land and sea. The sprouts began evolving and changing into many types of plant life upon Anothearth, within the sea and upon the continent. These same thrived and multiplied profusely until the planet became fertile and luscious.

The Arborstar tree was situated within The Garden Of Delight that was located in a valley in the middle of a range of peaks named The Mystic Mountains. This mountain range was located at the equator and ran from East to West in a slight curve directly through the middle of the continent of Anotherealm. Because of its favorable location and the many natural steam vents and hot springs within the valley, The Garden Of Delight was a tropical paradise, ideal for development of the many varieties of plant life.

Then one night a miraculous event occurred and one smaller branch of the Groweed limb metamorphosed. It was significant enough to be of noticeable change and caused the limb to grow vines from the area influenced. These vines put forth a new variation of growths, which gave up the seeds of their flowers to the winds. By a strange anomaly of Nature, these went through a change into life forms of a higher order of evolution. After many millennia, they transformed into the Fish of the sea, Beast of the field and Fowl of the air. Even the terrifying Dinosaurs and the primitive Neanderthal originated from these beginnings. At the same time, there appeared a second star in the night sky and was named Calistrophus, which means Starshell.

Many millennia passed by uneventfully and then a massive comet appeared that was on a collision course with Anothearth and it struck the planet with such force that it caused the Anothearth to alter its orbit and distance itself from its Sun slightly. The turbulence caused by the collision reactivated many of the dormant volcanoes, the smoke produced and dust caused by the comet's impact shrouded Anothearth in perpetual darkness. The darkened sky and greater distance from its Sun caused the Anothearth to experience the Ice Age and the bitter glacial rivers crawled along the

surface of the planet, emanating predominantly from the polar regions and stretching over the surface of the Anothearth as frozen rivulets of ice. Even the ocean froze and life ceased to exist on the planet except for the plant life in The Garden Of Delight and the great Arborstar tree. The various steam vents and hot springs in this area provided sufficient heat for their survival. Also, the roots of the massive tree were buried deep below the surface and drew additional warmth from the molten core of the Anothearth.

Yet due to the frigid climatic conditions of the Anothearth the tree returned to a dormant state and produced no additional foliage and that which existed in the garden itself too did not flourish substantially. The great tree and The Garden Of Delight withstood the onslaught of the Ice Age for many millennia before there were any significant changes in the environment.

Then, once again the Anothearth returned to its stable, closer orbit about its Sun and the ice began withdrawing back into the polar regions and the planet was able to sustain life again. After a long time great forests flourished upon the continent and in the far Northwest region of Anotherealm grew one such collection of trees that was named Elforest for its inhabitants. In the Northcentral portion of the continent near The Mystic Mountains were two forests divided by an immense river that was named Noriver that ran in a Northern direction to the sea through the middle of Elforest. On the Western bank of the river near the mountains was the forest named Hollowoods. In the midst of the Northcentral region of the forest was a body of water that was called Bowlake by those who later inhabited the area. In that same vicinity on the Eastern side of the Noriver was the forest named Meadowoods. A large woodland also grew in the Southeastern region of Anotherealm called Glowood Forest and a river divided it like the Elforest. This current of water was named the Whitheriver and it ran in a mainly Southern direction from where it originated in The Mystic Mountains until it reached the sea.

From primarily the Northeast of the continent to the Southeast of The Mystic Mountains was a swampland and the Eastcentral area was named Moglands, while in the Northcentral to Northeast was a vast marshland that was called Edgeery Wastes. In the South coastal area West of Glowood Forest was a formidable crater left by the comet that had struck surrounded by a circle of boulders that were its remains. This area was called Boulderidge. The gigantic boulders of Boulderidge extended even into the Southeastern seaboard and this area was named Breedereefs. In the Westcentral region existed a sparse grassland called Warplanes and farther Southwest of this were a series of low lying and relatively smooth rolling hills that were named the Roundowns that ran from the mountains to the Southern ocean.

Covering most of the Southwest was a great area of sand dunes named ... Sandesert. In the Southwestern sea near the shores of Sandesert was a barrier of reefs in shallow water that was called Bareef. Farther Southwest in the ocean was a small island that appeared at the end of the Ice Age and this was named The Enchanted Isle.

For the next 50,000 years life flourished on Anotherealm and in the sea and the Arborstar continued to grow and prosper. A metamorphosis began to occur and through the process of evolution the entire tree's limbs and their branches began to produce wondrous varieties of succulent fruits, berries and floras.

There now appeared the light of a third star in the night sky as if to herald the coming of a new generation of life forms to appear for this did occur and this star was named Andromeles, which means Starace. To the West the same bough of the trunk containing the Groweed limb extended and then divided into three separate branches that each produced what were called Bulberries in reference to their appearance. These branches grew subsequent vines that began to produce flowers. The colors of the flowers that each vine produced (in chronological order) were pink, blue and white. When the flowers of the vines were pollinated and came into fruition the berries they produced were the same color as the flowers of their origin.

The berries themselves were enormous in size by comparison to those produced by similar present day plants. Upon ripening they fell to the ground to continue going through a lengthy period of continued evolution and then produced the most miraculous of living beings.

The first to evolve of the Bulberries were the pink ones. Although large by comparison to today's berries (nearly three inches in diameter), nevertheless they actually were berries. Once ripened and having fallen to the ground, they lie there undergoing a strange transformation. They developed into cocoon-like pods and within them formed a creature with features similar to those of a Human although of smaller stature and with some variations. The period of development for the individual within its pod was slightly over 100 years and then it emerged from its casing as a Pixy with wings of sheer gossamer.

Upon entering the world its delicate moist wings began to dry and harden like those of a Butterfly. The Pixy would flex them until it gained strength enough to fly and then it would instinctively soar up to the branch of its origin upon the Arborstar and begin caring for the semi-ripe developing berries of its origin. The Pixies were the first sentient beings to evolve from the Arborstar and they perfected an elaborate form of speech. Their words were extremely long in terms of syllabic content and descriptive and numerous in variety. They had devised a word for every known thing that came into existence. They were also first to devise the game of riddles and found great pleasure in creating one that was impossible to solve.

The next of the Bulberries to come into fruition were the blue ones and these formed pods like those of the Pixy although they were slightly larger. Almost 1,000 years had passed since the Pixies had come into existence before the blue Bulberries produced creatures and these were named Sprites. The period of development for a Sprite in its pod was about 30 years. Sprites also had wings similar to those of the Pixy and there was a larger population of these than Pixies in The Garden Of Delight. They were less interested in riddles than the Pixies and intrigued by the making of potions, especially for curing ailments.

Whereas, the Pixies had a commonplace language among themselves the Sprites each had their own specific dialect as a derivative of the basic language. Consequently, it was harder for them to communicate through speech even among themselves and they were argumentative in nature. They were impractical, quixotic beings and made nonsense of nearly everything they heard and learned. If a Sprite spoke of Tail Of Snake as an ingredient to a potion it could just as easily mean Snail Of Lake in reference.

It was another 2,000 years before the white Bulberries came to fruition and when they did they metamorphosed similar to their predecessors. These berries were slightly larger than those of the Sprites and once developed they produced beings named Fairies. The period of development for the Fairy in its pod was similar to that of a Human fetus and about nine months before it emerged.

All the offspring of the Bulberry floras had a luminous aura that shone the color of the berry of their origin. They were visible in darkness; especially the Pixies who historians believe were originally mistaken for Fireflies. A concentrated mist surrounded Fairies known as Fairy Dust. To come into contact with it would provide rejuvenation and increase in life span.

The Fairies had a well-established and respected matriarchy among their kind and were ruled by their benevolent and powerful Queen who was first-born of their lineage. The Fairy was the most levelheaded and intelligent of the Bulberry folks and one of these could easily answer almost any given riddle put to them and then reciprocate in kind with a riddle of their own, that was usually nearly impossible to solve.

Fairies spoke two languages among themselves; The more common or Standard Fairy tongue was most prevalent in use by their race and when in the presence of matriarchs of their kind they used their ornate Proper tongue. Fairies also created music and had powerful loud voices for their small stature.

The next limb of the Arborstar to bring forth living beings was the one that branched out from the lowest main Eastern bough of the trunk and produced what was named Watersweet fruit. From this evolved the creatures named Nymphs. The Watersweet was similar to a giant unripe Pear in appearance. It was about a foot in length and eight inches in diameter. Like the transformation of the Bulberry folks the Nymph lie encased in the fruit throughout its period of development. Once ripened the Watersweet fell to the earth and the outer skin of the fruit hardened over time as the growth

increased significantly in size. This period of metamorphosis took almost 10 years before the fully developed Nymph emerged from its casing.

The semi-ripe Watersweet fruit of its origin that the Nymph developed from had an overpowering effect on most of the other races if they came into contact with it. The fruit caused nearly everyone other than a Nymph who did so to become immediately enamored with the first person met after exposure. The Pixies had concocted an elixir derived from the Watersweet leaves that had an overwhelming euphoric effect.

Almost all those who drank this potion became totally infatuated with the first individual seen after consumption. Historians also recorded that after approaching a Nymph usually the beholder became infatuated with the creature. It was discovered the Nymphs also produced a scent that was similar in effect to the Pixies potion and the fruit itself. Nymphs were about four feet tall when fully mature and had beautiful Human-like features similar to those of the Bulberry folks although the Nymph did not have wings. The Nymphs did not have vocal cords similar to those of the Bulberry folks, but could mimic the sounds of Nature. Ancient fables told of the Nymph as having taught the wind to moan and the brook to babble.

The next limb of the Arborstar to evolve and produce a life form branched off from the same bough as that which produced the Watersweet and the flora of this limb was named Farmint. From it evolved the Sylphs. The succulent fruit of the Farmint was about the size of a small Watermelon and similar in consistency, although of an azure color. Once fertilized, the Farmint fell to the earth and began maturing on the ground and it too grew immensely in size as the outer shell hardened and in about 2 years the fully developed Sylph emerged from its casing. The mature Sylph was about five feet tall with features similar to the Bulberry folks also although it did not have wings either. The Sylphs were the first to tame the wild Stallions of Anotherealm and were empathic in their abilities to communicate, especially with animals. Their vocal abilities were similar to that of the Bulberry folks, for they had conversation frequently with these peoples and in the process developed their own particular words and language.

Millennia passed by before there was another form of being evolved from the Arborstar and in this time the Bulberry folks, Nymphs and Sylphs became prolific in population within The Garden Of Delight. Next of the limbs of the Arborstar to put forth a life form of sentient nature was the Eastern bough from the trunk of the tree above the one that contained the Watersweet and Farmint limbs and it produced the flora that was called Eartherb. It generated spores that were carried on the winds into the garden, where they were able to root in the earth and then produced Cactus-like plants with four limbs upon them.

When it became fully ripe the plant fell off its trunk to the ground to continue metamorphosing into a being named Aborigine. The period of time for the Eartherb plant from the point of departure from its trunk until it reached a fully developed Aborigine was about 3 years. When the Aborigines were fully developed they stood almost four feet tall of a somewhat stocky nature and had a dark brown complexion and short, black, curly hair. The Aborigine was the first of the Arborstar beings to be of an omnivorous nature. They hunted the wild Beasts of the field for food and ate the various edible plants, but not directly from the Arborstar for they considered this distasteful. The Aborigines were the first people to become nomadic and venture out of The Garden Of Delight.

All the other creatures feasted mainly upon the fruits and vegetables that grew only in the garden but the Aborigines being omnivorous ventured out of the garden to search for food and began populating most of the continent of Anotherealm. Since they had Human-like features and vocal cords, although did not associate with the other races their language was of their own origin and was far different from that of the other folks of the Arborstar. Their words were extremely guttural and existed of few syllables. The Aborigines were diplomatic and their first-born was their Leader. They also performed Holistic healing administered predominantly by their second-born who was the Interpreter for the group. He invented the written language of the first ancient Symbols and would cast a collection of the remnant bones of an Ox that had been properly prepared and had Symbols engraved on them upon the dried hide of the animal that had markings upon it to determine the various factors of a reading for inspired guidance. This was known as Whitherboning.

The next limb of the Arborstar to put forth a living creature was at the top of the tree, growing West. From it developed a succulent fruit named Metaleaf. It too resembled a Watermelon only it was about six inches in diameter and of a silver hue. The fruit fell to earth once ripened and then became enlarged and hardened like the Farmint fruit and after almost 50 years of development the being emerged from its casing and was named ... Dwarf. The Dwarf grew to a height of about four feet and was larger boned and stocky by comparison to the Aborigine.

Dwarfs were of a mixed complexion in general and their skin pigmentation varied from dark black to nearly albino. Their eye coloring was a most astonishing facet of their physical makeup ... for the eyes of a Dwarf were attuned not only to visual perception but intuitive, cognitive reasoning powers and would vary in tones and shades of the entire color spectrum in reference to their communicative powers.

The Dwarf also had an innate, natural sense of direction so that they were seldom lost in their journeys. Fable speaks of them as having taught the Birds to migrate over long distances without losing their way. They also had extraordinary memories and although they spoke a language of their own making, they had no written word initially. Similar to the Aborigines of Anotherealm at that time the Dwarf was an omnivorous being.

The Dwarfs had a commonwealth system of government and had an appointed council of Lords. Each Lord ruled over the main population of their district. The High Lord was also the magistrate who had the final decision in all matters of importance. Originally, the Dwarfs were nomadic and would travel abroad about the continent of Anotherealm in a Dwarfcompany led by their respective Dwarflord. In preparation for such journeys they would dry varieties of food to take with them for meals. The Dwarfs were highly industrious beings and originally became carpenters and constructed elaborate buildings to reside in out of the wood they harvested from the various forested areas of Anotherealm. They later developed their skills as artisans of masonry and metalworking and began constructing buildings of granite that they quarried from the Mystic Mountains.

They eventually migrated to the Eastern edge of Sandesert where they constructed a massive stone fortress named Mountowers that became their permanent residence. They also invented huge drilling devices and dug under the base of Mountowers deep into the Anothearth where they made numerous underground tunnels and passageways. These were intricate mazes within Mountowers and were ingeniously interconnected by unique monorails and elevators that operated on a magnetic principle.

They drilled so far into the Anothearth that they reached molten lava pools within Mountowers and with gigantic ladles they would dip into these pools and capture Lavagems and Lavajewels that were most highly prized by all the races of Anotherealm. These precious stones produced a perpetual, radiating warmth naturally for many years after removal from the pools and the various races of Anotherealm used them for additional heat during cold weather.

Next, the top of the Arborstar came into fruition and put forth succulent fruits about the size of Cantaloupes, although of a pale, Emerald color on the surface. They were semi-transparent and translucent and had a shine to them as if they were jewels. The fruit was called Gemelon and during the day when the sunshine was upon it the Gemelon fruit was so bright that it could be seen shining from a great distance from the Arborstar. At night the starlight and moonlight would shine upon it and be refracted in all colors of the rainbow. When the Gemelon fruits ripened and fell to earth they too went through a metamorphosis, some becoming enlarged and their outer skin hardening. For the Gemelon the period of development from the time it fell to the ground until the being emerged from its casing was almost 100 years and the creature it produced was called an Elf.

When the Elf was mature it was of a lean stature and about five feet in height. Like the growth of its origin the Elf had a pale, Emerald colored complexion. Their hair was dark black and long and straight and around them was an aura of light similar to that emanated by the Bulberry folks although not as prevalent. The Elf was primarily herbivorous, although not limited entirely to fruit and vegetables as were the Bulberry folks, Nymphs and Sylphs.

Although the Elves conversed with the Bulberry folks and were somewhat amused by riddles they had little use for non-constructive past times and were most intrigued by the Pixies and their potions.

It was immediately discovered that the Elves were not affected by the Watersweet leaves, its potion or the scent of the Nymph in the usual manner and consequently, the only ones who had any sensible communication with these creatures. It was not until the Elves evolved from the Arborstar that any being was able to approach a Nymph and when they met, the Elves began teaching them sign language that they had invented since the Nymph could not communicate language orally. The Elves themselves could speak and their language known as Elfintongue was a combination of the spoken words of the Bulberry folks, the Dwarfs and the Aborigines. Their written word was based upon translation of the Aborigine's Symbols.

The Dwarfs had frequent contact with the Elves and introduced them to carpentry and the Elves immediately became far more adept at woodworking than their teachers. They created ornate furniture that they traded to the Dwarfs in exchange for Lavagems and Lavajewels. No respectable Dwarflord was without a handmade, genuine, solid wood Elfinthrone in his main chambers. The Elves so greatly loved carpentry that they left The Garden Of Delight in search of lumber in the forests of Anotherealm.

Some went to Glowood Forest where the massive fort home site they constructed was called Everhavens. Others traveled to Elforest and there built fantastic mansions collectively named Hidever. From the lumber of Glowood Forest and Elforest the Elves also fashioned the most advanced and swiftest aquatic vessels of the time for sailing up and down the rivers and in the sea. The ships were fashioned such that the likeness of the Sea Horse was upon the bow of the vessel and within its head were two special Lavagem eyes that produced brilliant light that would penetrate through fog, which helped the Elves avoid running their ships aground.

The Elves were also the first to delve into the sciences and it was they who first charted the movements of the celestial bodies such as the stars in the sky and in observing their motion and the rising and setting of the Sun and Moon of Anotheearth they devised the calendar. They also devised the Sextant and Compass and shared them with the Dwarfs who being more mechanically inclined made improvements upon these devices.

The form of government that the Elves maintained was democratic in nature. Their aspirations were to elect those members of most excellent skills to the tasks that suited them appropriately.

From the Fairies the Elves had learned the art of music and with their exceptional woodworking skills created and constructed musical instruments whose wooden bodies produced unexcelled sound qualities.

Almost 1,000 years after the Elves had become prolific in Anotherealm the top far right limb of the Arborstar growing East became fertile and produced succulent berry-like growths that were named Dewhisper berries upon the numerous branches that grew on the limb. These were small by comparison to the other berries produced by the tree and nearly transparent and gelatinous in form. When they became ripe they fell to the ground similar to the other growths of the Arborstar and developed and enlarged and after about 25 years they had become what appeared as miniature Humans about six inches tall but in actuality were called Tiny Ones.

These mysterious Little People were extremely nimble, highly energetic, adept and quick. They could move and hide from view so fast that it seemed as if they had disappeared right before an onlooker's eyes. Although they did not have wings they were capable of taming the wild Birds of Anotherealm and would ride upon their backs when the Birds took flight.

The Tiny Ones soon learned to become the greatest Chemists that ever existed and could produce gold that was highly treasured by all the races of Anotherealm. They would prepare a formula in a pot and then wait until a rainbow appeared on rainy days and place the mixture in the pot at the end of it. The chemical reaction of the ingredients and the spectral reaction of the colors of the rainbow would transform the mixture into gold. Two fables came into existence at that time based upon the Tiny Ones: One was that there is a pot of gold at the end of a rainbow and the other fable was that if someone recognized a Tiny One they would be granted three wishes in exchange for anonymity of the Tiny One.

The Tiny Ones also enjoyed riddles immensely and devised the basic form of portraying one poetically. They usually spoke in rhymes and cherished poetic verse above simpler forms of spoken

communication. As for the language of the Tiny Ones they spoke a dialect of the Proper Fairy tongue, for they were most welcome in the court of the matriarchs of the Fairies although they had a monarchy with the first-born of their lineage as King.

The Tiny Ones also learned music from the Fairies and although they played no musical instruments they had beautiful soothing voices with which they could mesmerize and tame the wild animals of Anotherrealm.

The Garden Of Delight was populated for many centuries by the various folks and myriad creatures of the Arborstar before there were any further developments by the tree. Then the second largest bough of the tree that was slightly above the largest bough and grew towards the South produced fleshy growths that were pink in pigmentation and shaped like the present day Mandrake root only much larger.

The singular growth was named Leafig and when it was fully ripened it fell to the ground to continue developing. After almost a year it had the likeness of a Human. In fact, it was the first actual Human for this was to become Man of Anothearth who was born there in The Garden Of Delight. At the same time a most brilliant celestial body appeared in the Eastern night sky and this was named Teleus and this interpreted meant The Eastern Sun and it was also called The Eastar and received its name in honor of the hailing of the arrival of Mankind.

Actually, it was not a star, but was a flaming comet that had fallen out of orbit around its Sun and into an orbit around Anothearth. It orbited the planet in the same direction as the rotation of Anothearth only at a slightly faster rate and appeared as if to sink into the Eastern Sea at certain times.

As the Leafig growths developed upon the grassy soil, they became large and after about 30 years fully mature adult Men were lying there in a state of hibernation until they gradually awoke. When the first Man awoke from his deep sleep and looked around him he became curious about his surrounding environment. Especially other Leafig growths that were nearby and in various stages of development that he discerned were others of his race in the process of maturing.

As more of the Leafig growths matured and produced Men their numbers grew and Mankind quickly spread throughout the continent of Anotherrealm, even making his abodes in the Northwest Elforest as well as Meadowoods in the midst of the continent and the eldest of Mankind who was King of their race had his gigantic fortress that was named Earthalls built in Hollowoods. He also occupied Glowood Forest and was somewhat nomadic but not to the degree of the Aborigines and at times could be found traversing the bleak, hot and dry Sandesert. Man was omnivorous in nature similar to the Aborigine although much more diverse in taste.

From the other races such as the Elves and Dwarfs he learned the mastery of the arts, sciences and technologies that they developed. From the Dwarfs he learned masonry, forging of metals and metalworking and the knowledge of mechanical devices and systems. From the Elves he learned carpentry and how to construct musical instruments and combined these with his knowledge of metalworking to produce unique musical devices.

The language of Man was of his own making although it had striking resemblance to the language of the Aborigines, for originally they had provided him with the translation of the Symbols and he in turn applied his own specific interpretations of the meanings and pronunciations and converted them into a written alphabet.

Man was tallest of all beings yet to exist upon Anotherrealm during that time and was an average height of almost six feet and those of his race produced by Leafig growths were extremely long-lived having many hundreds of years in life span.

Below the Leafig limb near the base of the Arborstar's trunk growing to the East was the greatest of all limbs upon the tree and the first King of Leafig was about 300 years old before it came into fruition. When it did it produced a pithy growth resembling the present day Beefsteak Mushroom although gigantic by comparison and this was named Earthorn. Once this was fertilized it produced spores that the winds carried and spread throughout the four corners of the world.

Only those spores that fell upon the peaks of The Mystic Mountains continued to survive and develop, as this location provided a suitable environment for their growth. Even so, few of the

Earthorn spores matured and these went through a long period of development before they produced anything.

Yet when they did, from the smallest spore grew the most gigantic of beings ever to walk the face of the continent. This was a gigantic replica of Man with the particular difference of having only one eye that was situated in the middle of his forehead. This titanic being was named Cyclops and stood almost thirty feet tall.

When the first-born of the race of Cyclopes was fully developed and awakened within The Mystic Mountain range he hungered for knowledge and traveled all over Anotherealm in search of information. The first sighting of this Cyclops by Man was in Hollowoods. A scout on patrol from Earthalls saw him and was immediately frightened and ran back there to tell others the news of a gigantic Man-like being who had only one eye in his forehead. News spread quickly throughout the residents of Earthalls and they gave him the name of Loneye The Titan for they feared that he might be aggressive. He was actually a timid creature by nature and when he had his first meeting with the scout who ran in fright this also frightened the Cyclops. Thus, he kept his distance from the race of Mankind, although he was sighted numerous times by Men.

At that time the first-born Cyclops was without the comprehension of the speech of Mankind, although he had acute hearing and at times when groups of Men would go on scouting parties near where he was he would remain concealed within the trees and listen to their speech and began to discern the meanings of their words.

Eventually, Man and this Cyclops did begin to communicate when a scout met him in the woods and before the Man had a chance to run Loneye quickly explained that he would do no harm and was interested in making friends with Mankind. The scout took this information back to Earthalls and the news of the gentle Cyclops spread quickly throughout the land and soon Man and the Cyclops became friends.

Loneye returned to The Mystic Mountains of his origin often in search of others of his kind, but it was nearly another century before any other Cyclopes appeared. Meanwhile he applied himself to the task of becoming a shepherd and tended herds of cattle and Sheep for their milk. He also became the greatest gardener of the time and planted orchards and gardens throughout the continent for the Cyclops was not carnivorous and consumed only vegetables, fruits and the milk of his herds.

He became an excellent storyteller, for he had an uncanny memory not unlike that of the Dwarfs and gained renown for his ability to entertain crowds and people loved to gather around him and hear him tell his tales in his thunderous, booming voice. The Dwarfs also became friends with the Cyclops and held great respect for him and out of reverence for Loneye they wrought a gargantuan crown of gold that he wore proudly as first-born of his lineage.

After all these millennia the Arborstar dwarfed every other tree in size by comparison and its roots had even reached deep into the Anotheath, stretching along for thousands of miles beneath the surface of the continent Anotherealm.

One such root grew to the Northcentral area of Anotherealm and emerged in a natural Artesian spring located in the nameless foothills of that area. This root was named the Northern Faroot and it was fertile and within the spring produced a most intriguing and mysterious entity. This particular life form was known as The Oracle Of The Fountain for within the center of the pool of water formed by the spring a geyser would erupt and the oracle appeared in its midst. It was a most fantastic being, as it was capable of seeing the past, present and foretelling future events that would occur.

It was a symbiotic life form for it was actually attached to the Northern Faroot and above the root formed into a Man-like torso of an azure color. Its head differed from that of Man for it had seven eyes located around its head and upon each side of its head grew horns similar to those of a Ram.

The oracle was also capable of intuitive powers and could communicate in every known language of the races of Anotherealm orally. Yet, when it spoke in terms of future events about to happen it was most commonly as a symbolic simile.

Another root of the Arborstar grew to the Southeast and emerged in the center of Boulderidge and then continued until it grew out upon the sea and due to its buoyancy the root remained afloat upon the surface of the water. Here, branches eventually grew and upon them in time grew gigantic, semi-

transparent, metal-like pods that when ripe fell off the branches into the sea. Then they floated on the surface of the ocean and were carried by the tides to the beach around the area of Boulderidge where they continued to develop and formed into the most wondrous of creatures ... Draques.

The Draque resembled the modern day lizard only it was immense in proportion and had wings upon its back. It was also capable of breathing fire. When the first of the Draques emerged from its shell it clambered up the beach to the rocky embankments of Boulderidge where it could sun itself and dry. There it continued to mature, flexing its leather-like wings until they were fully dried and it was able to take flight. Instinctively, the first Draque flew over the sea and began collecting the pods of others of its race and deposited them in Boulderidge crater. Directly below the crater was magma that provided added warmth and allowed the pods to develop more quickly.

Within a span of almost 100 years from the time the first Draque matured there were numerous of these magnificent Beasts flying over the continent Anotherealm. The entire hide of the Draque was covered with iridescent, multi-colored, multi-faceted scales that were so tough that not even the finest Dwarfwrought blade could pierce its exterior. The fangs of the Draque were harder and sharper than the finest metal.

Most of the Draques were Male and larger in size than their Female counterparts. The Females had duller sheen to their hides in contrast to the brightly colored scales of the Males. Their wings were similar to those of a gigantic Bat and they were webbed and had opposable claws like a Bat and some Draques even had hands upon their wings.

The Draque was a mystical Beast for it was not only empathic but also had levitation powers and could traverse the space-time continuum. It would fly into the Warplanes of Anotherealm and conjure a vortex that it would enter and leave its present location and arrive elsewhere upon the continent. Sightings by the various inhabitants of Anotherealm such as Dwarfs, Elves and Men were reported of mature Draques using not only their feet to transport pods of their kind to shore but also through levitation power suspending the pods in midair near them.

The Draque spoke a sibilant language due partially to its bifurcate tongue and it was almost indecipherable by comparison to the languages of the other folks of Anotherealm. Although the Draque could communicate in the languages of the other individuals of the continent who had linguistic capabilities this Beast was rarely socialized with by them since it was a primarily carnivorous and aggressive animal. Also the fact that it was capable of incinerating almost anything with its breath if provoked caused most of the peoples to stay as far away from one as possible.

The next root of the Arborstar to bring forth entities was the one that grew almost directly South into the Warplanes and was named the Watchorn root. There in the midst of the Warplanes the root surfaced and from it grew a gnarled appendage that was named the Knotree.

The Knotree grew for about 1,000 years before it began to produce any growths upon its limbs. When it did these were coniferous kernels that ripened in succession and fell to the earth to develop upon the sparse, grassy lowlands of the Warplanes. Eventually this tree resembled the Arborstar for its growths and put forth a variety of creatures, collectively named Horbeasts.

Similar to the Arborstar the first of the kernels to ripen and fall to earth produced a strange Beast named the Griffaera. When full grown this creature had the head of a Lion, a Goat's body, wings of an Eagle upon its back and the tail of a Serpent.

The Griffaera was a formidable, untamed Beast of the wild. It found its home in The Mystic Mountains although at times it could be seen flying over the Warplanes in search of prey, as it was a carnivorous creature. It had animal-like vocal cords and it would let out a loud roar that would startle its proposed victim and catch them off guard. Those who became its victims it would corner and then hypnotize into a deep trance. Those who were not hypnotized were left behind in a mesmerized state from which they rarely recovered.

The next kernel of the Knotree to mature and produce a creature created a hideous Beast named the Man O'Saur. Like other offspring of the Knotree the Man O'Saur was a combination of creatures.

This Beast had the body of a Man and wings. It too had the power to hypnotize its victims, similar to the Griffaera. The Man O'Saur also made its way from the Warplanes into the middle of The Mystic

Mountains where there were not only hills and caves, but also escarpments and ravines where the Man O'Saur made its home. It was known to perch upon the ledge of a cliff and await a passerby and then soar down upon its victim while uttering a dreadful shriek. It was not capable of full flight but could glide for short distances on air currents.

The Man O'Saur did not have a language of its own but was capable of speech and learned words of various languages from its victims but had little reasoning power and would torment each of them into answering ridiculous questions for its amusement.

The next kernel of the Knotree to drop to the ground and flourish produced the quixotic creature named the Harpette. The Harpette too was like previous creatures of the Knotree in that it was a conglomeration of two life forms. It had the body of an Ape-like creature with the claws of an Eagle on its arms instead of hands.

The mature Harpette was a cruel and sarcastic creature for it would make snide remarks about the appearance of others and harass anyone who was in its presence. If they did not depart quickly it would attack them.

It settled in the dreary Moglands where it was seldom encountered due to its inherent solitary and secretive nature. The Harpette also had the power to mesmerize other creatures similar to the Man O'Saur and the Griffaera, although this effect was not permanent. The Harpette did this by confusing its prey in a raspy voice to distract the creature it met so that they were caught off guard and were startled and it was by this means that it gained attention.

Upon gazing into its eyes its victim entered a trance. If they were not attacked, when they awoke from their dream-like state the Harpette had departed and they were not aware that it had even been there at all.

Then Teleus reached a cycle where it could be seen every night for many years and the Knotree flourished under its rays and put forth several kernels that ripened upon the bough. These fell to earth too and continued to develop and produce hideous creatures named Gargoyles.

There were two distinctly different variations of this creature. One resembled a Monster with wings and it had a bifurcate tongue and forked tail just like a Draque. This particular form of Gargoyle was a deep, dark, crimson color and upon its arrival into the world the other inhabitants of Anotherealm spoke of it as a being from the Underworld that had been sent to plague them.

The other Gargoyle resembled a grotesque transformed Vulture in form. Both of these types of creatures were capable of flying about the continent and were also capable of the Chameleon-like quality of being able to alter their features such that they appeared to be made of stone. Fables came into existence that the statues of such creatures built atop the ancient towers were actually living Gargoyles who had transformed themselves and were awaiting the arrival of a Holocaust when they would return to their natural form and wreak havoc upon the world.

Neither of these forms of Gargoyles was capable of oral conversation although like the Harpette they could mimic words and phrases that they had heard in their extremely raspy voices. These creatures followed the migratory path of the Harpette to the coastal Moglands and even ventured as far North as the inhospitable Edgeery Wastes.

Those few travelers to these areas who had sighted these creatures brought back tales of Monsters dwelling among the crags and that they would entrap the unwary wayfarer and enslave them to do their bidding.

Then the Knotree put forth a large kernel that developed for about 300 years and grew to immense dimensions and a hideous creature emerged from its casing and this was named the Scorpio. It resembled a Scorpion in form although many times larger for it was as huge as the large Beasts of the wild and many times more deadly than its miniature counterpart. It also had wings that resembled those of the Draquefly and would soar about the continent menacing and frightening every other creature in existence.

Then another large kernel of the Knotree dropped to the ground and began growing and became immense in size also and formed into what was the most monstrous of all Spiders in creation, the deadly Arachnid named ... Tyrantula. It was even larger than the Scorpio and even this creature

avoided the Tyrantula for this Spider-like creature was immune to the Scorpio's sting but the Spider's poison was deadly to the Scorpio.

The web that the Tyrantula wove was made of transparent strands that were stronger than steel and even the fiery breath of a Draque could not destroy the webbing of the mighty Spider. The strands also had an adhesive property that the strongest of Beasts could not break free from once entrapped.

Under the mystical rays of The Eastern Sun Teleus, two roots of the Arborstar grew Southwest through Sandesert all the way out into the sea unto the region named Bareef. The first root to come to fruition was the Waterroot upon which grew a strange form of sea Anemones that over a period of almost 500 years developed into the wondrous and beautiful creatures named Mermaids.

The Mermaid had the upper torso of a beautiful Woman and from the waist down a tail like a Fish. The hair colors of these fantastic beings varied greatly among their kind from pure white, to auburn and even jet black and all of them grew it extremely long in length. They all had fair complexion. Eye colors among them resembled priceless gems and ranged from Amethyst, to Sapphire, to Turquoise to Ruby red and many other variations of the color spectrum.

They had the most astonishing glow to them of inner light and these beings had the power to hypnotize other creatures. Fables spoke of sailors who had seen these wondrous beings having become enamored and dazed by them and running their ships aground.

Although they could and did hypnotize other creatures it was not to use them for any ulterior motives. Their act of hypnotism was to ensure that the being they placed in a trance would not have any wrong intentions towards them and would remain steadfastly infatuated with them and willing to do their bidding without question.

Sailors who had been hypnotized by these beings seldom returned to the shore of their origin for they were deeply in love with the Mermaids and wished only to be continuously in their presence and serve them faithfully.

Almost 150 years after Mermaids came into existence the Southwestern Fyroot that was the companion root to the Waterroot in the Bareef came into fruition and grew sea Anemones similar to those that had produced the Mermaids.

When these were fully developed they brought forth the Male counterparts to the Mermaids named Mermen. The Mermen were similar to the Mermaids in that they were part Human and Fish, only in this instance from the torso up Man-like and from the waist down they too had a tail like a Fish. They were also of fair complexion with various hair and eye colorings similar to the Mermaids. Although in contrast the Mermen shorn their head hair and some of them had substantial facial hair such as beards, mustaches and sideburns.

Merkind (as these beings were called) were highly civilized and became extremely advanced in the areas of ecology, technology and the sciences. They learned to harness the power of the Atom itself for they had built safe and efficient pure nuclear reactor domes far beneath the surface of the ocean, in the deep trenches that lie in the sea, North of The Enchanted Isle.

Where the Southwestern Fyroot continued into the sea past the area where it produced the sea Anemones of Mermen, a vine stretched out from the root and this was called Waterhorn. From the Waterhorn vine sprang growths that when they matured produced extremely vivacious creatures named Sirens.

The Siren was similar in appearance to a Woman, although the features of these beings were strikingly seductive by comparison. Unlike Merkind, Sirens were not aquatic and from the first one that floated up on the beach of The Enchanted Isle they all took refuge in the caves on the Northern coast of the island. Along with being gorgeous in appearance they had beautiful, mesmerizing voices and would sing to sailors at sea whose boats passed near the island off shore. The lilting melodies of the Sirens were so potent the mariners would go into a dream-like state and become unconscious and usually their ships would wreck upon the rocky reefs surrounding the island.

By now, the continent of Anotherealm was becoming well populated with the variety of creatures inhabiting it and then one cold, clear night in the Western sky appeared a most malevolent light from a star that had appeared to view. Its malicious ultraviolet hue permeated the atmosphere of the planet

and altered some people and plants of the Anothearth. This terrible star was called Malispo; The Wanestar or Doomoon; The Moon Of Doom.

The Beasts of the world had some sensibility before Malispo arose and certain of them could be tamed, although with the arrival of this devastating light in the sky nearly every Beast of the field became ferocious and wild. Some of the Dwarfs were also afflicted by Malispo and went mad and concocted an elixir that they administered to the Metaleaf succulent fruits and altered them.

From these bizarre experimental growths sprang the detestable plant named Warmelon. When the Warmelon matured it produced one of the strangest creatures yet to exist ... the Troll.

These creatures were most gruesome, thriving in the light of Malispo and hiding from sunlight, for under its intensely pure rays they would become petrified as if turned to stone. They were larger than Dwarfs by comparison and of a stocky build and did not have the complexion of the Dwarfs. Instead they had a gray, coarse, hairy hide and a pallor complexion. The Trolls were carnivorous in nature and even the Dwarfs who created them feared them for these creatures were uncontrollable. The Trolls were brutes of little intellectual power and dwelt in caves, except at night. Then they would conceal themselves in bushes along paths and when a passerby approached they would attack them.

Also affected by Malispo's deadly rays were those of the Dwarfs who ventured out of Mountowers too long during its appearance at night. These same became the cohorts of the Dwarfs who had gone mad and applied the malevolent mixture to the Metaleaf fruits. When these growths were altered they produced a disgusting plant named Harmelon that when it came to fruition produced the ignoble Goblins.

The Goblins were most despicable creatures and resembled the Trolls in their complexion. They too were larger than their counterparts, the mad Dwarfs and even of a stockier build than the Trolls. They were also even less intelligent than the Trolls who at least could speak a derivative of the vulgar Dwarftongue, while the Goblins would only cackle and howl in cacophony at the approach of a potential victim. They sharpened their pointed teeth with a rock of flint and around them was a most unpleasant aura of strange color combinations that fluctuated with intensity even at night.

Unlike the Trolls the Goblins were not adversely affected by direct sunlight, although they too preferred to appear at night for they had acute night vision and were able to see potential victims and attack before they were noticed. Even some of the original Dwarfs who had spent all their lives under the stars became lunatic with the rising of Malispo and allowed the mad Dwarfs to administer their appalling potion to some of the Metaleaf plants. Although they tried reluctantly to alter the growths unlike the ignoble plant life produced by the previous dosages these developed into what was named Weatherb.

It gained its name from the fact that it was totally toxic to all other creatures except those beings created by it. Those who sprang from the Weatherb were totally unlike the Trolls and Goblins for the offspring of this plant were the mysterious, yet wise and noble benefactors ... the Gnomes.

The Gnome resembled a mixture of a Dwarf and Elf for this was a small being, husky in stature like the Dwarf but with the smooth, translucent complexion and fair features of the Elf. The Gnomes made their way from The Garden Of Delight where they originated into the forest areas of Anotherealm and populated Elforest, Hollowoods, Meadowoods and Glowood Forest.

The Gnomes were adept in their ability to control the growths of the trees and nurtured them so that the highest branches interlaced throughout the wooded areas. The Gnomes then used these branches to travel across the forests. They could travel quickly and nimbly and were never known to lose their footing. Gnomes primarily spoke a dialect of the proper Elfintongue that they had derived and developed over a period of many years, although they were known to converse in other languages with the other learned folks of Anotherealm.

The mad Dwarfs stopped administering their appalling concoction to any further Dwarf Metaleaf plants and there was not that great a population of Gnomes upon the continent of Anotherealm.

The mad Elves did take the Warmelon and Harmelon growths and transplanted them all over The Mystic Mountains and as time went by Malispo continued to glower upon the continent with its deadly rays, Trolls and Goblins propagated profusely in the mountains. Even some of the Elves went mad from exposure to the light of Malispo and became the cohorts of the mad Dwarfs.

The reign of terror of Malispo reach its climax in a massive confrontation between the Elves and Dwarfs on the side of good and the Goblins and Trolls teamed with those of the Elves and Dwarfs who were mad and intent on atrocity.

The mad Elves and Dwarfs had created a large army of Trolls and Goblins within The Mystic Mountains and together they finally attacked The Garden Of Delight and planted Warmelon and Harmelon all about the Arborstar. Yet the great tree's strength was its defense and no malign growths would take root.

The sane Elves held a council and proposed a joining of forces with the normal Dwarfs of Mountowers in an effort to oust the foul creatures from the garden. Both Elf and Dwarf in Dwarfwrought armor with swords of enchanted steel swept down in masses upon the host of foul creatures in The Garden Of Delight.

The Trolls and Goblins had only stones and clubs for weapons, although they were extremely powerful and greatly outnumbered their opponents. The beautiful lush fields of the blessed hidden valley of the garden were impervious to the despicable folks, yet they came on in hordes down from The Mystic Mountains to surround the valley.

Finally, the valorous Elves and Dwarfs fought their way to the center of the garden and reached the Arborstar. The battle raged on throughout the day and soon darkness would overtake the benevolent beings when Malispo would again arise, giving added strength to the decrepit creatures.

The head of the council of Elves, Galinor fought most fiercely striding ahead of the other warriors in the midst of the detestable creatures. He forged his way alone through the ring of Goblins and Trolls surrounding the Arborstar and then valiantly began climbing the gigantic growth.

During the council meeting before the battle it had been decided by the Elves that Galinor would climb the mighty Arborstar and take a branch of Gemelon from it to be transplanted far North in Elforest where there were few of the dreadful beings and it could flourish in safety. As Galinor made his way to the top of the tree the good Elves and Dwarfs surrounded the base of the Arborstar to protect him and the branch he was to carry. They drove off the foul creatures from the bottom of the tree as Galinor reached the top and clipped the branch with his sword and then began his descent.

Once he was on the ground he and the good Elves and Dwarfs fled for safety, for the Sun of Anothearth was sinking on the horizon and the malignant entities would become even more powerful under the rays of Malispo once it appeared. Galinor had thrust his mystical sword Fyrbyt into the ground near the trunk of the Arborstar and it glowed ablaze with the energy of purity. Especially at night and the mad creatures would avoid it and no longer planted their ugly growths near the tree.

The Elves amassed and took the graft of Gemelon far North into Elforest and there they transplanted it and in time it began to prosper and put forth beautiful fruits similar to those of the Gemelon. These growths flourished and were called Timelons. When the Timelon fruits ripened they produced Elves who were similar to those of Gemelon and these being descendants and having been told of their origin regarded those Elves of Gemelon to be their ancestors.

Even though the trunk of the great Arborstar was no longer afflicted with abominable growths around it, for the power of the sword Fyrbyt had disabled them, it still put forth another hideous root. From the Wateroot of the Mermaids grew a malicious vine that was called Growatch. Upon it grew frothing nodules which secreted spores carried by wind and sea to the shores of The Enchanted Isle.

Here they beached upon the sands and congealed into a mass that developed into a hideous being named ... the Gorgolyte.

It was absolutely terrifying to look upon and had the body of a sleek Beast, although of a pale, jaded shade with deep, dark, red eyes that glowed with malignancy. Also where the Sirens and Mermaids had hair the Gorgolyte had instead a head covered with living Snakes. The Gorgolyte was capable of causing anyone who looked upon it to become petrified in a trance and the fable came into existence that if one looked upon such a creature they would immediately turn to stone. It too made its home in the rocky caverns of the Northern side of The Enchanted Isle, but avoided Sirens for these same were not affected by the Gorgolyte's visage and thus could not be entrapped in a trance like other creatures.

It was because of sightings of Sirens and missing sailors who had become entrapped by the Gorgolyte that the mysterious Enchanted Isle was spoken of in legend as a most mysterious place and mariners who sailed the Southwestern sea would keep their distance from the island.

Then the Arborstar seemed to enter a semi-recovering state since Galinor had planted his sword Fyrbyt in the ground to ward off the gruesome creatures and a root that had grown to the West under The Mystic Mountains surfaced within the volcano named Everock.

This was named the Fyrbush root and it emerged deep within the caldera of the volcano and from it formed a cluster of growths that appeared as if they were glowing intensely hot grapes. From the fiery globules a most magnificent feathered creature was created and this was the fabulous Phoenique.

The plumage of the Phoenique was pure white and radiated a glow and the Bird appeared as if it were on fire itself. It flew about the continent of Anotherealm and then once every 500 years it would return to Mount Everock to be consumed by fire and then rejuvenate itself from the cluster of fiery globules.

The malignant star Malispo grew in power over the years, terrorizing the night sky and only when Teleus was in alignment with it was it safe to venture out at night. In a final stroke of devastation The Wanestar began pulsing and emanating powerful, malignant rays that struck the Anotheath like immense lightning bolts, searing whatever they touched. Where they hit the sea the water would boil and upon land where they struck, gaping crevices were left behind. The pulsing of Malispo in this manner grew in strength, severity and frequency and the entire planet was deluged with the frightening bolts of light and every creature in existence took refuge to avoid being destroyed by the malevolence of this occurrence.

Then a devastatingly large bolt of the malevolent light struck the bough of the Leafig on the Arborstar and severed it from the tree and there was no more of the long lineage of Mankind to be born from this noble growth. When this occurred and became evident to Man, the heart and essence of all Mankind was anguished and sank into despair and their eldest, the good King Arcturius who was master of Earthalls in Hollowoods traveled abroad seeking aid to Man's dilemma. He sought to find the great Galinor and his followers of Elfkind for he had heard of their transplantation of the Gemelon branch that had produced the Timelon Elves.

Arcturius took a company of eleven Men with him and they all searched among the abodes of Elforest for the whereabouts of the Elves and were met one day in route by an Elf of Timelon, whose name was Borimus. Upon explaining their plight to the Elf, Borimus suggested that they employ a Cyclops to help in the transplanting of the Leafig bough for it was immense in size and would take a whole troop of both Elves and Men just to carry it to a safe place where it could be transplanted and a Cyclops could easily carry the bough alone.

Arcturius and company headed Northeast from Elforest to the area named Lostown that was the residence of the Cyclopes. They traveled through the nameless hills and strange rock formations until they reached the monolithic structure that was the sacred site erected by the gargantuan beings.

They approached the mysterious Cromlech with its Dolmen of secrets in the middle of the structure. Here they found a giant sea Conch shell mounted on a base that was to be shouted into to amplify the voice and summon a Cyclops.

Arcturius called upon the great apparatus and two of the Cyclopes beckoned to his call. The Men waited patiently and within a few minutes felt the earth rumbling beneath their feet at the approach of the gargantuan beings.

When the Cyclopes arrived the first who spoke to them was Tameye whose eye in the middle of his forehead was brown in color. Arcturius told him of their predicament and then the other Cyclops, who was called Stoneye and had a gray colored eye told them he was not only a shepherd but a gardener and that he would help them in their awesome task of transporting and transplanting the Leafig bough.

Together, the Cyclops and Men left and headed straight for The Garden Of Delight to take the Leafig bough and transplant it. Stoneye had brought a mixture of poultice that he had prepared for this endeavor and told the Men that it was to be used in grafting the bough onto a root of the

Arborstar. After consultation it was agreed that the bough would be taken from The Garden Of Delight to an area slightly North of Boulderidge and grafted onto the Southeastern Fyroot, where this part of the Arborstar emerged.

Stoneye informed the Men that this was a most favorable area for the grafting of the bough and it would be more prone to growth due to the added warmth of this region's ground and its inherent fertility. Once the company reached The Garden Of Delight the Cyclops hefted the humungous bough and carried it Southeast by himself at a rapid pace that the Men could not keep up with and they watched as he strode quickly out of sight.

Reaching the chosen area Stoneye carefully searched until he found an area of the Fyroot that extended far enough below the surface to allow the grafting of the bough onto the root and to be covered with the rich soil of that terrain. He returned to his home North and often came to visit the site of the grafted bough and to care for it and nurture it so that it would take root and flourish.

After a period of about 50 years the Leafig bough had become sturdy and healthy and had transformed into what was named the Clovestrap tree for it had grown limbs upon it and was fertile. It had put forth a bough to the Northeast that had numerous branches upon it and each had a wonderful bouquet of blossoms and these growths were then called Leafflowers. When these flowers upon the branches were in full bloom they became pollinated and cast their seed to the wind and some of it was born high over the mountains into the lush area of The Garden Of Delight and they flourished and produced pods and these eventually developed and produced the companion to Man Of Leafig for these were the females of him in likeness and were called Women Of Leaflower.

Arcturius who was King of Men cared for the first pod to develop when he found it and when it matured and the first Woman awoke he named her Bezeltha, Queen Of Women. He took her into his Kingdom of Earthalls and under his kind tutoring she became acquainted with the mysteries of the continent of Anotherealm. When the other Men Of Leafig saw the beautiful Queen next to their King upon their thrones they eagerly awaited the development of others of her kind to become their companions also.

It was not long before the courts of Earthalls were graced with many such Women, each who had their own Man as a lifelong companion. Although the Leafig limb having been transformed no longer produced any more Men, these Men and Women were able to have children as their offspring.

After Galinor had stuck his sword Fyrbyt into the earth at the base of the Arborstar the Goblins and Trolls retreated from the garden, believing that the sword was an omen that they would lose their essence if they came too close to it. Nevertheless, the mad Elves were not so easily convinced and they had returned after the great war and collected the last growths of the Leafig bough that were lying on the ground and to these, they applied their potion, in hope that they could produce an even more terrifying creation than the Goblins or Trolls.

Only one growth was transformed and this they planted in the garden at a safe distance from the Arborstar. It grew into a grotesque bush with limbs upon it resembling Snakes. Upon these limbs grew malign Figs. Because of its appearance the bush was called The Tree Of The Serpent. Any Man Of Leafig or Woman Of Leaflower who consumed the fruits of this bush lost their longevity. After the first few individuals of Humanity had ingested these deplorable Figs resulting in shortened life span, it was realized that The Tree Of The Serpent was the doing of the mad Elves and the Men destroyed it.

The next limb that grew upon the Clovestrap tree appeared shortly after the Leaflower bough and it grew due East. When it finally grew to a sizable length, unlike the other limbs of the Clovestrap tree it was unable to sustain the light of Malispo without being thwarted in its growth. This limb was named Watcherb for the beings that it eventually produced. It put forth several unmentionable growths similar to fungi as large puffballs. When these ripened they burst and spread their spores to the wind and those of the spores that floated on the Northern winds to the Edgeery Wastes developed into gurgling masses of toxic slime within the marshes there.

Under the malignant light of Malispo the slime continued to evolve until wriggling forth from it were frothing forms like grotesque Humans. These continued to develop and when mature produced the Female Wagglers and Male Wareachers of the Edgeery Wastes.

The gaseous fumes from the hideous slime pools were toxic to the air of Northeastern Anotherealm for many years and only these horrid creatures could withstand it. Although they were hideous to look upon during the full light of day, under the malevolent influence of Malispo they could transform themselves through xenomorphism into beautiful Princes and Princesses.

It was they who also obtained the Watersweet growths and made them into a pure euphoriant. When they were in the transformed state of beautiful beings they would administer this potion to unwary travelers in their realm who then became their permanent slaves to do their bidding. Those enslaved by the Wagglers and Wareachers by this elixir eventually became disoriented and uncontrollable.

The Wagglers and Wareachers practiced narcissism and each Wareacher was accompanied by a coven of Wagglers. They could not only pose as beautiful beings during the night under the light of The Wanestar but could transform themselves into terrifying Werewolves and Vampires in the evening under the light of the malevolent star.

In the historical journals of Anotherealm there is a tale told of one Woman of The Garden Of Delight who became curious about the inhabitants of the Edgeery Wastes and upon discovering one such Wareacher, consumed the elixir of the Watersweet that he had prepared and she became a seductress and enchantress under the spell that it produced upon her.

Eventually, the potion drove her mad and she wandered aimlessly about the continent. When she reached Boulderidge she found one of the Draquene pods and took it. Meanwhile, the Female Draquene that was caring for her nest of pods returned to find one missing and smelled the scent of Womankind in her nest. Immediately enraged at the transgressor, the Draquene flew directly to the site of the Clovestrap tree and sundered the limb of Leafflower from it in retaliation.

When Queen Bezeltha received the news of the severed limb of her birthright she was bereaved and sent a messenger to the Cyclops Stoneye notifying him of the awful catastrophe that had occurred. The messenger informed him of the incident that had occurred and beseeched him to do his best to save the limb of Leafflower. Once again Stoneye the Cyclops came to the aid of a graft taken from the Arborstar and took the sundered limb of Leafflower to the West where he grafted it onto the Waterroot. Under the care of Stoneye the Leafflower metamorphosed into a tree that was called Branchorn.

Eventually, a limb of the tree grew to the Southwest and this was named the Clawwood branch. In time it grew a strange cluster that seemed to resemble a giant Bird's claw. This eventually fell to earth and matured to transform into the gigantic, Vulture-like Fowl named the Roc.

The Roc was larger than all other Birds with a wingspan well over fifty feet and it too became the companion of Stoneye the Cyclops, for it sensed that he was responsible for its existence. It traveled about Anotherealm, gliding upon the air currents and was sighted by many of the inhabitants of the continent.

At the end of the Branchorn was a limb that eventually grew to the Northwest and this was called the Nightalon branch. Upon it grew gigantic nuts similar to Acorns in appearance that dropped to the ground to mature into the mythical Beasts called ... Gryphons.

Each of these creatures had the body of a Lion with the head and wings of an Eagle. Unlike the Roc, the Gryphons were totally carnivorous in nature and the peoples of the continent were cautious not to approach one of these animals. They were capable of swift flight and usually flew together in a group and were seldom seen individually for they hunted in a pack.

Another limb also grew from the Branchorn tree to the Southwest and this was named the branch of Heartherb. Once it grew to fruition it produced strange, pulsing globules that all the intelligent races of the continent used for medicinal purposes. These globules were first picked and air dried in direct sunlight and then removed at night when Malispo arose in the sky so that it would not contaminate them and then when they were fully dried they were ground up into powder and mixed with other ground herbs to be used for their curative powers.

Then one fateful night when Malispo was glowering down upon Anotheath the Goblins went to the Branchorn tree and hacked the Heartherb limb away from the tree. This they took far to the Northern reaches of Edgeery Wastes and gave to the Wagglers and Wareachers. These same loathsome

beings did everything in their power to alter the limb, yet it survived unblemished, so strong was its endowed strength of purity.

After all these events had occurred another star appeared one night on the Western horizon and it was called ... Galeus. This interpreted meant Westar and Man called it The Evenstar. The strength of Galeus was not as great as that of Teleus although these two stars now shining in the night sky diminished the debilitating effects of Malispo by their combined luminance and this in turn benefited the growth of the Arborstar.

Despite this event the massive Earthorn bough was decaying and eventually fell to earth. Arcturius gathered his troops together and they took the Earthorn bough Southeast to Glowood Forest. Here they showed the bough to the Elves and after consultation it was agreed that together they would transport the bough in a Sea Horse ship unto The Enchanted Isle.

The Men and Elves took to the sea in the Elves ship and when they reached The Enchanted Isle Arcturius and his Men buried the base of the bough in the fertile soil of the mystical island. Then the King and Men erected a slab of basalt that they had quarried from the cliffs of the island.

As a memorial to the Earthorn bough of the Cyclopes birth upon it they inscribed, 'When Malispo will fade in eternity, then Teleus The Eastern Sun shall reign supreme and life will flourish.'

Then Arcturius and his Men and the Elves departed, returning to the mainland in their ship and expecting little to come of the transplanted Earthorn bough. The bough did flourish and put forth many branches and it was called The Tree Of Hearthorn. Upon its limbs grew globules that pulsed similar to those of the Heartherb, only these were in the exact shape of a Human heart. These bulbs ripened over a period of years and fell to earth where they grew in size and then matured into that which appeared to be Men, but in truth were the ominous Wixaerds Of Hearthorn.

The Wixaerds were of fair complexion and taller in stature than even Man himself. They had great mystical powers and eventually constructed sailing vessels from the wood of the trees of The Enchanted Isle and sailed to the mainland where they became acquainted with the other races of Anotherrealm.

They learned much from the other peoples of the Arborstar and concocted miraculous potions not only from the Heartherb globules but from the many varieties of floras growing upon the continent. They were also capable of casting spells of great strength to ward off disaster. It was the Wixaerds who first were able to proceed to Boulderidge and begin communication empathically with the Draques of that region. They trained the terrific Beasts to allow the Wixaerds to mount and ride upon the backs of Draques and soar off into a vortex of time, arriving in the past, present or future at will.

Malispo continued to shower its hideous rays upon the Anothearth and the population of Goblins and Trolls had grown immense. The Wagglers and Wareachers had also grown great in numbers and had built a sacrificial temple in the North Edgeery Wastes named Watchalls. Even these despicable creatures could be seen venturing in The Mystic Mountains near The Garden Of Delight and the gentler races were perplexed as to what to do about the vile beings.

The Elves sent messengers from Elforest unto all parts of the world for the Dwarfs, Elves of Glowood Forest, Wixaerds of The Enchanted Isle and Men to meet at Earthalls and prepare for a battle with the hideous creatures that was called ... The Growar.

The forces of good left Earthalls and headed East along the edge of The Mystic Mountains for they did not wish to enter the regions of the mountain range as of yet, for it was plagued with the population of Goblins and Trolls. When they reached the pass that led to The Garden Of Delight they were immediately confronted by swarms of Goblins, Trolls, Wagglers, Wareachers and even Gargoyles. The troops gathered to defend good realized that these foul creatures must have heard of the impending attack and amassed in great quantities.

Under the directions of the Wixaerds who had taken mount upon the Draques they appeared through a vortex and began driving the iniquitous beings away. Once again the brave warriors who faced the despicable creatures were able to reach The Garden Of Delight and Galinor regained his mighty sword Fyrbyt. Climbing the Arborstar again he reached the top and took another branch of the Gemelon of his race. Elves, Dwarfs, Men and Wixaerds mounted on Draques vanquished the repulsive folks and drove them back into the Edgeery Wastes.

Then the Wixaerds cast a Spell Of Protection upon The Garden Of Delight and it was never again plagued by misfortune. Galinor and his Elves took the second branch of Gemelon to Elforest and here they planted it and in due time it grew to become the Realmelon tree and produced succulent fruits. These same matured and developed into Elves also.

The Wixaerds who had their Draque mounts flew even unto the Edgeery Wastes and made havoc upon the Wagglers and Wareachers of Watchalls and recovered the precious Heartherb limb. Then the Wixaerds on their Draques flew back to The Enchanted Isle where they planted the Heartherb branch next to the Hearthorn tree and it flourished and from its many branches that produced wondrous growths they were able to make not only powerful potions but also made Whitherwands out of the branches.

For millennia Anothearth was populated by the creatures of the Arborstar and its grafts:

Fish, Beast and Fowl of Groweed;
Pixies, Sprites and Fairies of Bulberry;
Nymphs of Watersweet;
Sylphs of Farmint;
Aborigines of Eartherb;
Dwarfs of Metaleaf;
Elves of Gemelon, Timelon and Realmelon;
Tiny Ones of Dewhisper;
Men Of Leafig;
Cyclopes of Earthorn;
The Oracle Of The Fountain of the Northern Faroot;
Draques of the Southeastern Fyroot;
the Griffaera, Man O'Saur, Harpettes, Gargoyles, Scorpio
and Tyrantula of the Knotree of the Watchorn root;
Mermaids of Wateroot;
Mermen of the Southwestern Fyroot;
Sirens of Waterhorn;
Trolls of Warmelon;
Goblins of Harmelon;
Gnomes of Weatherb;
the Gorgolyte of Growatch;
Phoenique of Fyrbush;
Women Of Leaflower;
Wagglers and Wareachers of Watcherb;
the Roc of Clawood;
Gryphons of Nightalon
and the Wixaerds of Hearthorn.

After many millennia had passed by in that legendary time the remainder of the stars had begun to appear one by one until the night sky was bedecked with the light of many stars.

In the ever expanding Universe the original celestial bodies became so distant the light of Aureleus The Starflower, Calistrophus The Starshell, Andromeles The Starace, Teleus The Eastar or Eastern Sun, Malispo The Wanestar or Doomoon and Galeus The Westar or Evenstar had faded from the night sky and their powerful celestial rays no longer shone upon Anothearth.

Then the great Arborstar tree became completely dormant and no longer put forth any growths from its limbs or roots and finally hibernated. By this time all the folks of the tree were growing old with the passage of time and some were nearly immortal, yet with the fading of the light of the stars of their origin, even the eldest of these beings went to their destiny one by one.

All that remains of these are the mortal races of their ancestors. Many stories were written about those legendary times when all the wondrous creatures inhabited the Anothearth and these

documents were sealed in secure containers for posterity and were not discovered until the continent of Anotherealm had broken up into separate landmasses and even so, many of the writings believed to be existent have not yet been recovered.

These writings were originally in Wixaerdword and upon the discovery of numerous of them diligently transliterated.

ANOTHEARTH FABLES

Sojourn Of The Dwarfs

This tale tells of the migration of the Dwarfs from The Garden Of Delight unto the Western Edge of Sandesert and the construction of their dwelling place, the massive Mountowers.

After having dwelt amidst the delights of the garden for uncounted years, Dwarfdom had grown exceedingly great in population. First-born Lord Of Metaleaf, Talletor called upon his people to gather to listen to him for he had experienced a vision that would forever change the lives of the Dwarfs.

He said unto them, "A vision came to me in my sleep. In it appeared as if to be a Messenger from beyond sitting upon a cloud of pure white. The face of the Messenger bore a likeness unto no other being as I have yet to lay eyes upon, for I was rapt in its power.

The Messenger lowered a rope woven of golden Polemonium down from the cloud and bid me to climb it to the summit. This I did and when I reached the resting place of this noble being he spoke unto me and said, 'Behold ... look unto the North and South and East and West that you may see all the Anothearth before you.'

This I did and it greatly pleased me for I saw all the continent of Anotherealm and even the mighty ocean surrounding it. Yet, ever did I look to the West to linger upon the sight of the setting Sun of Anothearth for it was upon the horizon at that time and this, the Messenger saw and observed that I was contented with the sight. Then the Messenger spoke again to me and said, 'Go ... bid your kind to hearken unto this vision and make haste to abide no longer in the garden but travel unto the Western coast to make your permanent abode.'

So I say unto you one and all that my bidding unto you is to live here in The Garden Of Delight no longer but travel unto the Western coast where we may take up our inhabitancy."

Some knelt upon one knee and swore allegiance to Lord Talletor but others questioned him at length about the vision and said, "But what lies West? There is nothing there but the desert and are we not the seed of Metaleaf of the Arborstar of The Garden of Delight?"

Talletor was not pleased with their lack of belief and went to his tent that night and slept restlessly and again the Messenger appeared. This time it looked down upon the Dwarflord in benevolence with its face radiant and the cloud it sat upon was brilliant with bolts of lightning emanating from it.

The Messenger spoke to Talletor and said, "I have given unto you and your kind my bidding, yet there are those who do not understand my words. Therefore, I tell you to get unto the West immediately. Go along the midst of the mountains and stray not into the foothills for I will enlighten those who do not comprehend."

Talletor was filled with awe and awoke immediately and summoned all Dwarfdom to him once again and bid them travel unto the mountains and not stray upon the way lest they be noticed by the Messenger.

Once again some of the Dwarfs asked him at length, "How is it that we have not heard of this Messenger ourselves? Let us wait upon the coming of this noble one that we may seek his guidance ourselves."

The Dwarflord excused those who were inquisitive and in the midst of night gathered his people about him and began the pilgrimage to the Western edge of Sandesert. They had not traveled many leagues from the garden in The Mystic Mountains before a light began to shine down as if from beyond and the Messenger appeared upon the cloud as described by Lord Talletor and spoke to all them at once and said, "Do not look back upon the way you have left behind for I shall surely turn all those who disbelieve and disobey me into believers."

Then arose a blinding flash at the backs of Talletor and those who followed him and their shadows fell long before them. Yet, there were those who were startled and looked back to see what had happened and when they did their belief was evident for they turned to follow and their doubts were swept away by the sighting of the Messenger that had arisen. Then did those who were with him believe even more in the visions of Lord Talletor and swore allegiance unto him to follow him unto the ends of the Anothearth if necessary.

The race of Dwarfs journeyed through the valleys within the mountain range and over the peaks of The Mystic Mountains and stopped often to dwell in the valleys for these were peaceful and beautiful

and abundant with fruit trees for their sustenance. Then did some of them sway from their word and approach the Dwarflord and said, "These valleys we find most pleasing and would stay here forever if you would give us grace to do so."

This troubled Talletor for the Messenger had told them to travel far unto the Western coast and that night when he slept he was visited again by the vision of the Messenger who said, "That some of you linger in the valleys and do not get hence unto the far West displeases me greatly ... for these are those who have great strength and fortitude ... come unto the mount at the end of this valley and I shall speak to you ... but bring no one else upon the mount with you."

Then Talletor journeyed unto the mount at the end of the valley they were in and began climbing to its summit. There were those who were very curious about this Messenger and said one to another, "Let us follow Lord Talletor at least to the edge of the mount, for the Messenger did not forbid us this much."

Thus, unsuspecting, Talletor was followed by those of his race whose inquisitiveness had not been quelled. When they reached the mount they could see that it was shrouded in clouds and the location of the Dwarflord was unknown to them. Then they said to one another, "Would it not be safe for us to go upon the mount, ever so far as the clouds that we might see the Messenger? If he does not espy us there will be no harm."

Some agreed with those who said this, but for the most part, the Dwarfs did not wish any further transgression against the Messenger, especially after the previous incident and they were reluctant and fearful to venture upon the mount.

Yet, there was one among them named Gattelor who was extremely curious and bold and said, "I shall go forth unto the mount and find a recess among the boulders where the Messenger shall not see me and from there shall I observe and embellish upon the visions of Lord Talletor and this Messenger."

Even as Gattelor was about to set foot upon the mount the Messenger spoke to him through clouds of thunder with lightning bolts that appeared immediately and said, "Lord Gattelor ... I know you as the Dwarf born of Metaleaf of the Arborstar and before you had set foot upon this mountain, I would have stopped you and all your race. Yet for your inquisitiveness ever shall the eyes of all Dwarfs lead them in the night as well as the light of day ... so that you see in darkness to halt your curiosity of the unknown and any danger lying there. Too, I give unto them as an ability ... all your race shall glean right from that which was unknown."

Then did Gattelor's hair turn pure white as if he had seen an apparition and he retreated from the mount. When he told the other Dwarfs of the incident they believed him and knew they had been told the truth for the night pleased their eyes as well as the light of the Sun.

For fifty-two days and nights Talletor did not come down from the mount and it rumbled and in the clouds upon it was lightning and Dwarfdom waited at its base, awaiting the edict of the Dwarflord. On the fifty-third day Talletor came down from the mount and he bore with him fifty-two thin gold tablets. Upon each one was one of the Truths Of Folding And Unfolding, wrought upon the plates of gold by the Messenger with his lightning bolts.

Then did the Dwarflord speak and said, "These Truths Of Folding And Unfolding I give unto you for a covenant ... go now to the far West of The Mystic Mountains, even unto the edge of Sandesert next to the great open sea as was commanded to me originally by the Messenger. You are also commanded to travel to and from The Mystic Mountains where you shall hew the living stone of the mountains into great blocks and transport them into the desert. There you shall build a magnificent fortress to abide in because you can now abide in shelter of darkness as well as the light of day."

Then Talletor led his people through the mountains unto the edge of the continent of Anotherealm and it was there that the Messenger came to him in a vision and instructed him in the construction of the fortress. The Messenger showed the Dwarflord miraculous ways to forge machinery and hew and transport the mammoth blocks of stone unto the desert from the mountains for the construction of their new home. Then did Talletor decree that the name of their great building should be in honor of the Messenger upon the mount and it was called ... Mountowers.

For many years the Dwarfs continued to build Mountowers and then the Messenger came to Talletor again in a vision and said, "It pleases me well that you have hearkened unto my bidding and therefore I shall give you reward." Then the Messenger showed the Dwarflord in a vision the means to tunneling underneath the great towers of the fortress and into the core of the Anothearth where there lie great molten pools of lava. The Messenger showed Talletor the means to fashion great ladles and use them to dip into the depths of the pools and withdraw precious gems of extraordinary beauty and mystical power. Thus ... all Dwarfdom lived contentedly and they prospered and had great wealth.

The Fifty-Two Truths Of Folding And Unfolding

The Fifty-Two Truths of Cyclic Foldings and Unfoldings consist of the Twenty-Six Truths of Folding and the Twenty-Six Truths of Unfolding.

The Twenty-Six Truths of Folding:

- 1 ... At Each Commencement of Foldings, Exists not any of these Elements Of The Cosmos for it is The Void: Reality, Space, Time, Dimension, Energy, Momentum, Matter, Form of Matter, Power of Matter, Life, The Tree Of Life, The Garden of Delight or its Floras or Faunas, Sentience, Intelligence, Imagination, Ingenuity, Invention, Power of Invention, Omnipresence, Omniscience, Omnipotence or Eternity.
- 2 ... Then does Commence The Potential of The Void, and this does The Void in its Potential: The Innermost Areas Of The Void Gain Potential and Fold Outward and The Outermost Areas Of The Void Gain Potential and Fold Inward and Exists Reality.
- 3 ... Exists then Reality in all its diverse intricacies.
- 4 ... Folds Reality in its diverse intricacies and Exists Space.
- 5 ... Folds Reality and Space in their diverse intricacies and Exists Time.
- 6 ... Folds Reality, Space and Time in their diverse intricacies and Exists Dimension.
- 7 ... Folds Reality, Space, Time and Dimension in their diverse intricacies and Exists Energy.
- 8 ... Folds Reality, Space, Time, Dimension and Energy in their diverse intricacies and Exists Momentum.
- 9 ... Folds Reality, Space, Time, Dimension, Energy and Momentum in their diverse intricacies and Exists Matter.
- 10 ... Folds Reality, Space, Time, Dimension, Energy, Momentum and Matter in their diverse intricacies and Exists Form of Matter.
- 11 ... For Form of Matter Exists of all these Foldings and possesses Substance and Shape.
- 12 ... Folds Reality, Space, Time, Dimension, Energy, Momentum, Matter and Form of Matter in their diverse intricacies and Exists Power of Matter.
- 13 ... Folds Reality, Space, Time, Dimension, Energy, Momentum, Matter, Form of Matter and Power of Matter in their diverse intricacies and Exists Life.
- 14 ... Folds Reality, Space, Time, Dimension, Energy, Momentum, Matter, Form of Matter, Power of Matter and Life in their diverse intricacies and Exists The Tree Of Life.
- 15 ... Folds Reality, Space, Time, Dimension, Energy, Momentum, Matter, Form of Matter, Power of Matter, Life and The Tree Of Life in their diverse intricacies and Exists The Garden of Delight and its Floras and Faunas.
- 16 ... Folds Reality, Space, Time, Dimension, Energy, Momentum, Matter, Form of Matter, Power of Matter, Life, The Tree Of Life, The Garden of Delight and its Floras and Faunas in their diverse intricacies and Exists Sentience.
- 17 ... Folds Reality, Space, Time, Dimension, Energy, Momentum, Matter, Form of Matter, Power of Matter, Life, The Tree Of Life, The Garden of Delight and its Floras and Faunas and Sentience in their diverse intricacies and Exists Intelligence.
- 18 ... Folds Reality, Space, Time, Dimension, Energy, Momentum, Matter, Form of Matter, Power of Matter, Life, The Tree Of Life, The Garden of Delight and its Floras and Faunas, Sentience and Intelligence, in their diverse intricacies and Exists Imagination.
- 19 ... Folds Reality, Space, Time, Dimension, Energy, Momentum, Matter, Form of Matter, Power of Matter, Life, The Tree Of Life, The Garden of Delight and its Floras and Faunas, Sentience, Intelligence and Imagination in their diverse intricacies and Exists Ingenuity.
- 20 ... Folds Reality, Space, Time, Dimension, Energy, Momentum, Matter, Form of Matter, Power of Matter, Life, The Tree Of Life, The Garden of Delight and its Floras and Faunas, Sentience, Intelligence, Imagination and Ingenuity in their diverse intricacies and Exists Invention.

21 ... Folds Reality, Space, Time, Dimension, Energy, Momentum, Matter, Form of Matter, Power of Matter, Life, The Tree Of Life, The Garden of Delight and its Floras and Faunas, Sentience, Intelligence, Imagination, Ingenuity and Invention in their diverse intricacies and Exists Power of Invention.

22 ... Folds Reality, Space, Time, Dimension, Energy, Momentum, Matter, Form of Matter, Power of Matter, Life, The Tree Of Life, The Garden of Delight and its Floras and Faunas, Sentience, Intelligence, Imagination, Ingenuity, Invention and Power of Invention in their diverse intricacies and Exists Omnipresence.

23 ... Folds Reality, Space, Time, Dimension, Energy, Momentum, Matter, Form of Matter, Power of Matter, Life, The Tree Of Life, The Garden of Delight and its Floras and Faunas, Sentience, Intelligence, Imagination, Ingenuity, Invention, Power of Invention and Omnipresence in their diverse intricacies and Exists Omniscience.

24 ... Folds Reality, Space, Time, Dimension, Energy, Momentum, Matter, Form of Matter, Power of Matter, Life, The Tree Of Life, The Garden of Delight and its Floras and Faunas, Sentience, Intelligence, Imagination, Ingenuity, Invention, Power of Invention, Omnipresence and Omniscience in their diverse intricacies and Exists Omnipotence.

25 ... Folds Reality, Space, Time, Dimension, Energy, Momentum, Matter, Form of Matter, Power of Matter, Life, The Tree Of Life, The Garden of Delight and its Floras and Faunas, Sentience, Intelligence, Imagination, Ingenuity, Invention, Power of Invention, Omnipresence, Omniscience and Omnipotence in their diverse intricacies and Exists Eternity.

26 ... Thus Exists all of these Elements Of The Cosmos in their diverse intricacies: Reality, Space, Time, Dimension, Energy, Momentum, Matter, Form of Matter, Power of Matter, Life, The Tree Of Life, The Garden of Delight and its Floras and Faunas, Sentience, Intelligence, Imagination, Ingenuity, Invention, Power of Invention, Omnipresence, Omniscience, Omnipotence and Eternity.

The Twenty-Six Truths of Unfolding:

- 1 ... Hence at Each Completion of Foldings is the Commencement of The Unfolding of all of these Elements Of The Cosmos in their diverse intricacies: Eternity, Omnipotence, Omniscience, Omnipresence, Power of Invention, Invention, Ingenuity, Imagination, Intelligence, Sentience, The Garden of Delight and its Floras and Faunas, The Tree of Life, Life, Power of Matter, Form of Matter, Matter, Momentum, Energy, Dimension, Time, Space or Reality.
 - 2 ... Hence Unfolds the Elements Of The Cosmos in their diverse intricacies and Exists not Eternity.
 - 3 ... Hence Unfolds Eternity and Exists only Omnipotence.
 - 4 ... Hence Unfolds Omnipotence and Exists only Omniscience.
 - 5 ... Hence Unfolds Omniscience and Exists only Omnipresence.
 - 6 ... Hence Unfolds Omnipresence and Exists only Power of Invention.
 - 7 ... Hence Unfolds Power of Invention and Exists only Invention.
 - 8 ... Hence Unfolds Invention and Exists only Ingenuity.
 - 9 ... Hence Unfolds Ingenuity and Exists only Imagination.
 - 10 ... Hence Unfolds Imagination and Exists only Intelligence.
 - 11 ... Hence Unfolds Intelligence and Exists only Sentience.
 - 12 ... Hence Unfolds Sentience and Exists only The Garden of Delight and its Floras and Faunas.
 - 13 ... Hence Unfolds The Garden of Delight and its Floras and Faunas and Exists only The Tree of Life.
 - 14 ... Hence Unfolds The Tree of Life and Exists only Life.
 - 15 ... Hence Unfolds Life and Exists only Power of Matter.
 - 16 ... Hence Unfolds Power of Matter and Exists only Form of Matter.
 - 17 ... Hence Unfolds Form of Matter and Exists only Matter.
 - 18 ... For Form of Matter Exists not after all these Unfoldings and no longer possesses Substance or Shape.
 - 19 ... Hence Unfolds Matter and Exists only Momentum.
 - 20 ... Hence Unfolds Momentum and Exists only Energy.
 - 21 ... Hence Unfolds Energy and Exists only Dimension.
 - 22 ... Hence Unfolds Dimension and Exists only Time.
 - 23 ... Hence Unfolds Time and Exists only Space.
 - 24 ... Hence Unfolds Space and Exists only Reality.
 - 25 ... Then Commences The Loss Of Potential of The Void and this does The Void in its Loss of Potential: The Outermost Areas Of The Void Lose Potential and Unfold Inward and The Innermost Areas Of The Void Lose Potential and Unfold Outward and no longer is there Reality.
 - 26 ... After all of these Unfoldings Exists not any of these Elements Of The Cosmos in their diverse intricacies: Eternity, Omnipotence, Omniscience, Omnipresence, Power of Invention, Invention, Ingenuity, Imagination, Intelligence, Sentience, The Garden of Delight or its Floras or Faunas, The Tree of Life, Life, Power of Matter, Form of Matter, Matter, Momentum, Energy, Dimension, Time, Space or Reality.
- So it is with the Laws of the Universe. That these Foldings and Unfoldings shall Cycle Repeatedly.

The Interpretation Of The Truths Of Folding And Unfolding

When the Lord Talletor of the Dwarfs received the Fifty-Two Truths Of Folding And Unfolding upon the mount the Messenger had also instilled within him the inspired interpretation of their meaning. Before the existence of these tablets Dwarfdom had no written word and even the tablets were inscribed in strange symbolic form that was indecipherable to all but Lord Talletor.

The Fifty-Two tablets contained the progressions of the Universe and their time of appearance in chronological order of events. These same golden tablets were sealed in a container and then a massive temple was built where they were stored and the entrance to the temple was sealed with one gigantic rectangular stone that had been mounted on massive spring loaded hinges from the inside. Once the stone was closed upon these hinges it automatically locked by a unique mechanism on the inside that made it impossible to open the stone door from the outside.

So carefully cut were the stones that comprised the temple that for all appearances it looked to be one giant monolithic block. This temple was the first and most beloved structure designed and constructed by the Dwarfs and then around it was built the mighty fortress of Mountowers with the temple being located at its exact center. At the exact center at the top of Mountowers was one very small opening that allowed light to enter. There was also a matching small opening in the top of the temple. According to the instructions of Lord Talletor this was located such that the light of a specific star to come into view at a predestined time in the future would trigger the stone Timecaliper that sealed the entrance to the temple to open at the precise moment that would be the beginning of the enlightenment.

Although the tablets in the container had been sealed in the temple the Dwarfs had made replicas of the tablets such that they could be translated so that all races of the continent Anotherealm would be shown these truths and realize that there existed such an entity as the Messenger that had visited the Lord Talletor and that these truths were not artificial.

The translation into the written word of these noble laws of the Universe did not occur until the existence of the race of Aborigines who invented the Symbols. Subsequently the Fifty-Two Truths Of Folding And Unfolding were diligently compared and translated into the language of Man upon his coming into existence upon the Anotheearth.

The Lady And The Tiny One

There once was a tree that grew in the midst of a beautiful garden in a valley hidden deep within The Mystic Mountains of the continent of Anotherealm. This magnificent growth was called the Arborstar and at the very top of the tree, far up in the clouds grew a limb that produced small, gelatinous drops. The limb grew and branched out and these small droplets grew upon the branches tips and appeared as if to be merely drops of dew, hence the name given them was Dewhisper berries.

When they became ripe the gentle breeze blew them loose from the branches and they drifted down to settle upon the grassy plain of the garden. Those of the berries that were fortunate enough to land near Clovers with four or more leaves upon them soon transformed into the miraculous ... Tiny Ones.

One such Tiny One was a merry little fellow named Sir Theogames, or so he called himself. All the other Tiny Ones simply called him Theo. Unlike most of Tiny Ones who wore green clothing this fellow had a jacket made of bright yellow Butterose, pants of gray Willoweed and black shiny boots made of Watchorn. For you see, he traveled about extensively and had won these items in wagering upon the riddle game with other folks that he had met.

Little Theo was a very capricious fellow and very lucky too, as you see ... the Clover that he had been born next to had seven leaves upon it. One day it had been raining mist all morning with the clouds lying low in the sky and a cold breeze blowing. Then the Sun of Anothearth broke through the clouds and the Tiny Ones were certain a rainbow would appear and were preparing to concoct pots of gold under the light at the end of the rainbow.

Theo already had pots of gold stored all over the garden and much gain from his endeavors and was not interested in the making of more wealth this particular day. So, when the rainbow appeared and the rest of the Tiny Ones hurried towards its end with the gold pot mixture preparations, Theo sat on a giant Mewcap chewing on a piece of Grenweed and whistling nonsense to himself.

Also born of the Arborstar tree of those growths named Leafflowers were those beings named Women. Those who saw them said they were the most beautiful people and called them The Ladies Of The Garden.

When rain had been falling, the Ladies had taken shelter from the moisture and wind that had arisen. Now that the Sun of Anothearth was appearing through the clouds and the mist was beginning to cease they began coming out in the open to enjoy the loveliness of the garden, as usual.

One such Lady was the seventh born of Leafflower and a very beautiful Queen among Women. She had raven black hair and they said that her eyes were similar in appearance to those of the Tiny Ones whose eye colors changed for her eyes would appear to be brown at times and then change to green, blue, or even gray depending on her mood.

Her name was Sylthea and ever since she could remember she had gone to the plains near the Arborstar to pick the lucky Clovers, for among Women Clovers with more than the usual three leaves were considered lucky and Sylthea was extraordinary at picking these.

She would take them to show to the other Women and exclaim, "See! I have the Lucky Charms! Good fortune shall be mine!"

On this day Sylthea wandered about in the garden near the tree searching for the lucky Clovers and approached the area where Theo was. All the other Tiny Ones had left but he having no desire to go gold making sat reminiscing upon his Mewcap. He was so rapt in reverie he did not see the Lady until she was nearly on top of him.

Then he noticed her picking Clovers with four or more leaves upon them and thought to himself, "Glory Be! The Lady can find the birthplace of The Little People very easily!"

Before Theo got a chance to escape and hide beneath the giant Mewcap he sat upon the Lady Sylthea saw him and exclaimed, "Ooh! Look! It's one of The Little Folk I have heard of!"

Then she went over to him and introduced herself and said, "I am the Lady Sylthea, seventh born of Leafflower and a Queen among Women. I have heard of your people before, but you are the first I

have seen. Please tell me ... is it true that Tiny Ones have a pot of gold hidden somewhere in the garden?"

To this the Tiny One replied, "Why your Highness, I Sir Theogames am a true Tiny One and have never heard such a tale!"

Theo was lying to the Queen for he was greedy along with all his other faults and did not wish to share the gold.

Then Sylthea spoke and said, "Oh well, it was told to be a fable anyway and now that I have met one of your kind I understand the truth of the matter ... but look Sir Theogames, I have Lucky Charms ... smell their wonderful fragrance!"

Then she held the Clovers she had picked under the chin of the Tiny One and just by chance she had picked a seven leaf Clover that brushed the chin of Theo. What the Lady did not know is that if one tickles the chin of a Tiny One with a Clover containing the number of leaves of his birthplace he will become instantly infatuated with the person who does so.

Theo fell into a trance and was at once in love with the beautiful Sylthea and said to her, "My Lady, I cannot lie to you now for you have my adoration. Yes ... it is true that Tiny Ones have a pot of gold as I have many myself and they are all yours for the taking!"

Sylthea clapped her hands in delightful glee and danced around merrily and gave Theo leave to go immediately and fetch one of the pots of gold for her. So he left and soon returned with a little urn that he had hidden in the garden and gave it to the Lady.

She looked at the shiny contents and then Theo told her of the mystical powers of this gold and she was ever so grateful to him that she gave him his freedom.

Then he told her of the birth of the Tiny Ones beneath the lucky Clovers and Sylthea became the midwife of his kind for she would find the Dewhisper drops beneath the tree and place them under lucky Clovers and she became fast friends with the race of Tiny Ones and was a very wealthy Woman for they brought her much gold ...

Legend Of Silverlark

There once was a mysterious island known as The Enchanted Isle for it was believed to be filled with mysticism and power. Upon it had been planted a bough that produced growths called Earthorns that originally grew on the greatest of all trees in existence called Arborstar. When this bough took root and grew it too formed into a tree named Hearthorn.

This growth was given its name for the fact that the tree was bright red in color and appeared as if it had gigantic arteries growing from the trunk. The branches upon it had growths each of which was in the shape of a Human heart. This tree grew for many years before even the first of these growths fully ripened and fell to the ground to continue developing. These pulps lie upon the ground pulsing like a heart and continued to grow in size as they slowly began forming into a body and lost their brilliant crimson color and became more of a light colored, flesh tone.

It was almost 30 years before the first of these reached full maturity and when it did it resembled a Man although of slightly greater stature and in actuality this being was the very first-born Wixaerd Of Hearthorn ...

Upon reaching a mature state the first Wixaerd slowly awoke from his deep trance-like state of growth. He slowly arose to his feet and looked around him, noticing the tree of his origin and other of its growths in various stages of development and from this he was able to discern his beginnings. He also noticed a stone slab erected near the tree that had strange markings engraved upon it and wondered about this for it appeared to have been placed there and was not a natural formation. He instinctively thought that there might be others of his kind or similar beings who had placed the slab there and that its markings were an inscription of some form of communication.

Thus, out of curiosity the Wixaerd began searching about the island looking for others of his race or someone at least similar to him that could enlighten him concerning his origin. Although he searched for many days he saw no one like him and his only companions were the many varied forms of Birds and wildlife upon the island.

One day his searching brought him to the great mountain in the midst of the island and he found a cave-like entrance and entered to search for whatever it might hold. When he had entered he saw that there was a tunnel leading farther in and following it he came upon a cavern not far from the entrance so that there was some light and once his eyes had adjusted to the darker interior, he noticed a wooden trunk situated in the midst of the cavern. Opening the trunk he found within it a pure silver colored robe and pointed hat of the same color and a book with markings in it. He donned the robe and hat and then took the book out into the open and in the light of day he looked through its pages and found pictures next to the various markings that obviously depicted their meanings.

The book must have been created by beings similar to himself, for there were pictures of such kind. Additionally, some of the markings seemed to be interpretations of some of the sounds made by Nature and certain wildlife for these same were shown corresponding to the markings. In the days that followed he learned to read and speak from the book by comparing its contents to those sounds made by Nature and some of its wildlife. Also contained within the book were pictures of various other beings and creatures that must exist on the large continent pictured and described in the book.

In time he was able to interpret the meaning of the inscribed slab of stone erected in commemoration of the bough of Earthorn of Cyclopes that now had become the tree of Hearthorn. He learned from the book that its writings were the Symbols of the Aborigines and by the innate nature of his being a Wixaerd he began deciphering some of them into forms of incantations with which he was able to perform feats of wonder. One such feat was to teach the Larks of the island to sing with him in harmony and from the Symbols he had learned he named himself Silverlark from the fact that his clothing was silver and the beautiful, harmonious accompaniment of the Larks in song.

As time passed he became even more powerful and cast a Spell Of Invisibility about the entire island so that it could not be seen from the sea. Sometimes he would walk along the beach and watch the waves break upon the shore and on one day in particular he had been walking there and as he was standing in the salty sea air he saw a ship afloat and anchored in the bay. He had no idea

how long it had been there, but obviously whomsoever was aboard might be in search of the island that was invisible to them at that time.

Silverlark spoke the incantation to break the Spell Of Invisibility and not long after that he saw a small rowboat lowered from the ship and figures in it that resembled what must be Men for they appeared similar to those same beings depicted in the book. He stood there upon the shore as the small boat was rowed towards it and when it reached the beach he could see that these indeed were Men and he went to greet them.

He spoke to them and although his language was slightly different in inflection it was recognizable to them. King Arcturius who had erected the slab and had left the book written by the Aborigines in Symbols, had them transliterated into the language of Man. The King was present at this historical meeting of the first Wixaerd and embellished on the planting of the bough of Earthorn, the erecting of the slab and the clothing and book that the Wixaerd had discovered.

The Wixaerd then guided the King and Men to the tree of his origin and its numerous growths in various stages of development and they were astonished. King Arcturius then offered to give Silverlark safe passage to the main continent of Anotherealm on the ship and the Wixaerd accepted for he was curious to investigate the continent and its large and varied population of creatures. The King, Men and Wixaerd returned to the beach and boarded the small rowboat and set out for the main ship and as they approached it Silverlark could see that it was in the shape of a Sea Horse and aboard ship were those beings that he recognized from the book as Elves.

When they reached and boarded the ship the Elfcaptain approached Silverlark and spoke in the speech of Man saying, "Greetings Wixaerd! This is a most joyous event! I am the Elf Dorimar and captain of this fine vessel. We were told by those who have visited The Oracle Of The Fountain that such as you would come into existence!"

Silverlark then explained to the Elfcaptain the nature of his origin and the presence of others of his kind in various stages of development, he being the first of his kind and having discovered his ability to perform miracles as was predicted.

Then Dorimar instructed his crew to set sail for the coast of Anotherealm and they departed from the island's bay headed due North. It was many days before they saw the Southwestern coastline of Sandesert. Upon arriving at the bay area there of Sandesert the Wixaerd requested that he be allowed to disembark. His main reason for visiting the continent was the fact certain incantations that he had deciphered were not effective on the island and proposed for the continent itself and various ingredients for potions and elixirs that the book contained were not available on the island and could only be obtained on the mainland.

Dorimar set anchor off the coast and sent a small crew of his Elves to take the Wixaerd to the beach and had provided Silverlark with dried goods and provisions in a backpack. The desert was a desolate place, with very few areas that had a nearby Oasis. Silverlark had been provided with detailed maps of the continent by the King and the Elves had provided him with a compass to determine his direction of travel and he set forth directly North.

He intended to visit The Garden Of Delight and the Arborstar tree for he had been told it was the origin of all living things and many of the floras needed for his potions grew in that vicinity. He was also hopeful that he might meet a band of Aborigines before reaching the mountains for he wished to have them help him better decipher the Symbols to enable him to create more potent potions and spells.

Silverlark set out and walked for over two months, stopping only to rest at night, before sighting anything other than the endless, relentless sand dunes. Then in the distance he saw a small group of travelers headed West. They also noticed him and stopped while he quickened his pace to meet them. As he approached them he could see that these were none other than Aborigines as described in his book. When he reached the band of nomads he began speaking to them and although it was more difficult than with Man, he had learned some of their dialect from the King and was able to communicate with them.

The first to greet him was the Leader of the group and he told Silverlark that his name was Puru Udubu. Silverlark told him he was the Wixaerd of The Enchanted Isle and then he removed his Book

Of Symbols from his backpack and showed it to the Leader. Puru gestured to the Interpreter of the group who had been standing off to the side of the rest of the Aborigines and he approached the Leader and Wixaerd and began conversing with Silverlark. He told the Wixaerd that he had written the Book Of Symbols many years before in accordance with the vision of Lord Talletor of the Dwarfs and then had translated it into the language of Man for King Arcturius who had left it on the island.

The Interpreter told the Wixaerd that his name was Calata Maba and that neither he nor any Aborigine knew a great deal about the meanings of the writings themselves. He said that he knew that the book contained a large amount of information concerning miracles but as to the practice of such he was awaiting the advent of a Wixaerd such as Silverlark for such feats to be performed.

Silverlark then told the Leader and Interpreter that he had procured some of the ingredients for potions from the vegetation on The Enchanted Isle. The Wixaerd, Leader and Interpreter discussed the matter at length and then decided that the following morning they would head West towards Mountowers to visit Lord Talletor. Perhaps the Dwarflord would know more about the book's contents that he could reveal to the Wixaerd.

The Aborigines and Wixaerd made camp that night and in the morning started their journey. They traveled for two months at a steady pace, stopping at any Oasis that the Aborigines knew was near the direction they were headed in and then they sighted the mighty stone fortress of Mountowers on the horizon. In a short while they had reached the Northeastern entrance to Mountowers and were greeted by the Dwarf who was on duty at the entrance that was open at that time.

He hailed the approaching visitors and said, "Hello my fine travelers! It has been a long time since we last saw you! But ... who is this stranger in silver clothing that you bring in your midst?"

To this the Leader replied, "This is the Wixaerd Silverlark of The Enchanted Isle, first-born of the Hearthorn of Earthorn of The Tree Of Life, the Arborstar!"

The Dwarf was amazed and immediately welcomed them in and told the Leader and his party to proceed into the Northcentral tunnel to reach the chambers of Talletor.

They did so and traveled for many days through the passageway observing the numerous tunnels branching off the main one they were traveling through and stopping at available rooms occasionally to rest. The inside of Mountowers was dimly lit for the Dwarfs had acute night vision, as well as great vision in bright light.

Just as Silverlark was about to ask Puru to stop for a rest after a long period of travel they came upon a set of double doors at the very end of the tunnel with a large, hinged brass ring knocker on the right hand door. Slowly, both doors were opened from the inside by the two guards on duty and the Aborigines and Wixaerd progressed into the conference chambers of Lord Talletor. The Dwarflord was seated in an immense chair at the end of the very long conference table in the center of the main chamber.

At this time Talletor was alone, except for the two doormen who had opened the doors and stood at the entrance on guard and he hailed the incoming party, "Aye! It is Puru Udubu and Calata Maba and their group and a stranger dressed in the robe woven by Man for the coming of Wixaerds! You must undoubtedly be the first of their fabled kind of The Enchanted Isle ... come near me if you would, Wixaerd and speak to me of your kind."

Silverlark approached the chair Talletor was seated on and kneeling as he had been instructed to do previously by the Leader of Aborigines he said, "Your Honor, Lord Talletor ... I am Silverlark, a Wixaerd from The Enchanted Isle as you have assumed."

Then the Wixaerd removed the Book Of Symbols from his backpack and handed it to the Dwarflord and Talletor began reading through its pages, occasionally nodding to himself in affirmation.

Talletor sat silently reading through the book for a long time before speaking again and Silverlark was relieved to hear him break the silence when he said, "Yes ... there is much about this book that you can learn from me. I see you have found good companionship in my friends the Aborigines who can also tell you of the location of some of the various herbs and plants needed for your potions. I will expound upon a great deal of the contents of the book to better inform you."

This greatly pleased Silverlark and the Dwarflord sent one of the doormen to inform those of the Dwarfs who would be instrumental in helping to decipher and translate the encoded formulas of the Book Of Symbols to meet at the designated hour. Then he dismissed the Aborigines and Wixaerd until then so that they might obtain refreshments and rest.

Having prearranged quarters for their visits the Aborigines proceeded to depart while the other doorman ushered the Wixaerd to his sumptuous quarters to do likewise. After a period of much needed rest the Leader and Interpreter and the Wixaerd returned to the Dwarflord's main chamber and the other Dwarfs were already gathered there. There were numerous chairs along the sides of the great conference table and the summoned Dwarfs sat at their respective places of posterity with the eldest and wisest ones closest to Talletor.

The Dwarflord had instructed the Wixaerd to sit at the nearest chair to him on his right while the Leader and Interpreter of the Aborigines took the two respective closest chairs on his left.

Once they had all assembled and been seated Talletor addressed the meeting and said, "We have gathered here for the purpose of aiding the greatest of all beings yet to come into existence ... a Wixaerd!"

As he spoke this he gestured towards Silverlark and then continued saying, "As I have told my people for many years, Wixaerds would come into existence and in the vision when I saw the Symbols that were devised as Symbols Of Folding And Unfolding I was also instilled with knowledge of those Symbols contained within the book that was left by King Arcturius for just such a person as this. It is now our role to help decipher and translate this Book Of Symbols for the benefit of all living beings."

Then the group began discussions, extrapolating the theorems and formulas of the book more precisely and informing the Wixaerd of the whereabouts upon the continent of the various plants and herbs that each Symbol represented. After four days of consecutive meetings they had deciphered the encoded portions of the Book Of Symbols to the extent that each spell and potion contained therein was more specifically clear to the Wixaerd and the Interpreter of the Aborigines wrote down additional parchments containing this information for Silverlark.

Then having finished the business at hand Silverlark and the Aborigines left the mighty Mountowers under the instruction of Talletor to head East unto Glowood Forest to meet the Elves there at Everhavens who could supply the Wixaerd with a great number of the various ingredients he required for his potions, instead of having to procure them individually himself.

First the group headed North towards the foothills of The Mystic Mountains. Here there was foliage and it was not as harsh as the stark, parched Sandesert they had previously traveled through although the journey through areas of underbrush was slower. The weather was still very hot due to the close proximity to the desert but more bearable. Once they had reached the foothills they progressed towards the East along them and they were not for lack of comfort for as was customary the Dwarfs had provided them with ample supplies.

After many months of traveling they reached the area where the smooth, rolling Roundowns met the mountains and they headed Southeast. Continuing their journey they reached the basin of that area named the Warplanes. Puru informed Silverlark about the Warplanes inhabitants and that some of them were dangerous Beasts born of the Knotree there and that they should be cautious traveling in this area.

It was nearly sundown the day they reached the Warplanes and they knew they would be forced to spend some of their time here. They made camp and built a bonfire and Puru sent four guards to the perimeter of the camp and one Aborigine to scout out the territory. A few hours after camping they heard a scream from the distant plains. The guards rushed out waving their spears and returned shortly carrying the scout. His hair had turned from black to gray and his face was pale. He mumbled incoherently about being attacked by some strange Beast that had come upon him by surprise. Before it got to him he had seen it and ran towards the camp and so was badly scared, but unharmed otherwise.

The Wixaerd administered a small vial of elixir containing Lemonime, an antidote that the Dwarfs had provided him with that brought the Aborigine scout back to his senses and then he more

precisely described the creature he had encountered. Puru and Calata both agreed that this could be none other than the dreaded Man O'Saur. They told Silverlark of the creature and asked if there were any spells he might cast to ward it off.

Searching through the Book Of Symbols he found a spell that required Watersweet powder of the Nymphs of the Arborstar and knew that the Dwarfs had provided him with a small quantity of it. Taking the powder from his backpack he told Puru that he was headed in the direction that the scout had been brought back from. He assured them that he had the power to tame the Beast and would return safely to camp after putting this menace to rest.

The Wixaerd left camp headed in the direction where the Man O'Saur was believed to be and after about half an hour of investigation he saw the Beast lurking near a large boulder. It had not sighted him yet and he sneaked around the backside of the boulder. He poured a small amount of the Watersweet powder into his hand and just as the Man O'Saur came around to the side of it that he was on he blew the powder into its face and spoke the Spell Of Taming to make the creature temporarily docile.

The Man O'Saur backed up and fell to its knees in a stupor. Its eyes became glazed over and it looked fondly at the Wixaerd. Silverlark began speaking to it calmly and commanded it not to harm anyone. The Beast under the influence of the Watersweet was obedient and was able to speak somewhat in its hoarse voice and told the Wixaerd its name was Scosynchus.

Silverlark told Scosynchus to head South, back into Warplanes towards the Knotree and the Beast turned and headed off in that direction. Returning to the Aborigines the Wixaerd told them of the confrontation with the creature and they were amazed. No one before had ever had any control over the mighty Man O'Saur and they praised Silverlark for his actions. Then the group had a fair night's rest although Puru did keep guards on duty for there were other Beasts in the Warplanes that were not hospitable.

The following day they broke camp and for about two weeks they traveled uneventfully until they reached the Western Glowood Forest and the Whitheriver where it ran down from The Mystic Mountains. Following the river they headed South in the direction of Everhavens. They had not spent many days traveling down river before they sighted one of the Elves Sea Horse ships. The Elfcaptain of the ship saw them and immediately anchored the ship to the Western riverbank.

As the travelers approached the ship the Elves were coming off the gangplank that had been lowered and the Elfcaptain greeted them, "Good Day! This is a pleasant surprise to see a group of traveling Aborigines and their guest ... my name is Boliton and I am captain of this vessel." Then he addressed the Wixaerd, "Who might you be stranger? The likes of you I have not seen before."

Silverlark replied, "I am a Wixaerd from The Enchanted Isle and have come to the continent of Anotherealm in search of certain ingredients for my apothecary of potions. I was able to obtain a small quantity of the various herbs from the Dwarfs at Mountowers, yet I have been told your people have a great store of such items".

To this the Elfcaptain replied, "Yes, we are considered as some of the greatest Chemists in the world, although a Wixaerd would be viewed as far more adept than we ourselves. My people have a large variety of the various herbs and spices found on the mainland that they would be able to provide small quantities of."

Silverlark told the Elves of his encounter with the Man O'Saur and the fact that it was no longer a threat to anyone since he had tamed it and they were amazed. The Elfcaptain invited the group of travelers to board his ship and once everyone was aboard they took up anchor and headed downstream. Traveling in the ship with the current of the river was much faster than on foot and within a week they had reached the dock where they set anchor and left the ship. The Elfcaptain left a guard aboard and everyone else began to travel through the forest to the home of the Elves in Glowood Forest.

They headed West and after four days they reached the gates of Everhavens. Boliton hailed the guards at the gates upon their arrival and they opened them wide to allow the party of travelers to enter. This was the first time Puru and his small group had ever been to Everhavens and they were

amazed at the size of it. Built completely of wood and adorned with gems, the halls of the Elves seemed nearly as enormous as the Mountowers of the Dwarfs.

The Elfcaptain himself was renowned among the Elves and led the party into the main meeting hall and they were all seated at a gigantic round table. Then he sent Ushers of the Elves who were attendants of the hall to gather the High Council together for a meeting with their newfound friends the Aborigines and Wixaerd. He also sent one Usher to bring the Elfpharmacist whose name was Tomilon to obtain the list of ingredients required by the Wixaerd.

In a short period of time the Elves had gathered and the Wixaerd produced the Book Of Symbols and additional parchments from his backpack to aid the Elfpharmacist. Silverlark began leafing through the documents and reading them out loud and each time he came to the name of an herb or spice stored in their depository Tomilon wrote it down on a list.

When Silverlark had finished his reading Tomilon excused himself and took the Wixaerd's backpack and went to fill his prescriptions. He returned in about half an hour with Silverlark's backpack filled to the brim with herbs and spices. He had been thoughtful enough to label each packet of individual ingredients so that the Wixaerd would know their contents. There were a few herbs not available to the Elves such as Watcherb as used by the Wagglers and Wareachers for their horrid incantations and the Wixaerd had decided that he would obtain every single substance in the Book Of Symbols before returning to his island.

He told this to Puru Udubu and mentioned that he wished to visit the Edgeery Wastes to obtain the Watcherb in the form it was used by the horrid personages so that he could analyze it and make an antidote. The Leader was adamant to venture in that area as were the other Aborigines, for to approach a Wagglers or Wareacher was dangerous. Silverlark spoke earnestly to Puru and assured him that there was nothing to fear as long as he had the ingredients that he did, for there were potions and spells to overpower even a Wagglers or a Wareacher. The Wixaerd managed to persuade the Aborigines to journey with him unto the Edgeery Wastes and guaranteed that he would not leave them unprotected at night when such creatures as inhabited that area were most likely to be confronted.

The Elfcaptain Boliton had picked up his store of supplies for his ship and since he was leaving also he agreed to transport the party upstream on Whitheriver until his ship could go no farther because of shallow waters. Sailing upstream would be much slower going against the current but still much quicker than traveling on foot. After a luxurious and sumptuous meal and refreshing night's rest at Everhavens the entire party of Elves, Aborigines and Wixaerd departed and headed East back to the ship. The return trip also took four days and then boarding the ship with additional provisions the Elfcaptain hoisted the mainsail and they began heading upstream.

In about two weeks of time they had traveled upstream so far as to see The Mystic Mountains looming before them in the distance. Here, it became too shallow for Boliton to go any farther with his ship and setting anchor on the Eastern shore the Aborigines and Wixaerd bid their farewell and began their journey Northeast to the passage through the mountains and unto the Edgeery Wastes.

It took them another two weeks on foot to reach the foothills of the mountains and then the journey began getting steeper uphill as they went along. Puru knew of the pass through The Mystic Mountains in this area and led the party along in that direction. After another two weeks they had crossed over the mountains and reached the other side and could see the forest of Meadowoods and the great Noriver beneath them in the flatlands to the Northwest. They continued traveling Northeast and down into Meadowoods.

After a month of travel through the woods, these began thinning out in quantity of trees and the ground was bog-like under foot. Soon, they were in the Northern basin of the Edgeery Wastes and there was nothing before them other than the mossy, wet earth and a few sparse Marshrubs, Flashrubs and Bushrubs. The branches of these they collected diligently as they traveled for there was nothing else for firewood in this area. From here they continued towards the Northeast and in the direction of the home of the Wagglers and Wareachers named Watchalls.

They traveled through the marsh for another two months before coming within close proximity of Watchalls. They made camp just out of sight of the home of the horrid beings. It was nightfall when

they made camp and Silverlark informed Puru and Calata that he planned a stealthy approach to Watchalls during the day when the Wagglers and Wareachers would be at rest. The following morning Silverlark set out in the direction of the home of the sinister beings. In about an hour's time he espied their dwelling place.

From what he had learned from the Book Of Symbols and other folks of Anotherealm the Wagglers and Wareachers slept during the day in coffins that each had a bed of Watcherb in them. There were no guards at the entrance for there was no one in their right mind that would approach Watchalls and so the Wixaerd sneaked into the building and down a flight of stairs to the basement where the coffins were kept.

The first one he came to he knelt next to and taking the packet of White Bulberry flower powder from his backpack he sprinkled a small amount of it into one hand. Then cracking the lid of the coffin with the other hand he blew the dust from his one hand into the coffin and let the lid shut quickly. He heard a muffled snarl and some scuffling inside it ... then silence.

He waited a moment longer and then opening the lid of the coffin could see that it was a Wareacher who was now in a state of suspended animation caused by the potent powder. He reached into the coffin and withdrew a few branches of Watcherb and closed the lid. Then he quickly retreated back to the Aborigines campsite. When he arrived he told the travelers of his triumphant encounter with a Wareacher and once again they were amazed at his prowess. No other being in existence had ever confronted a Wagglers or a Wareacher, let alone subdue one of these. Truly ... this Wixaerd was a most powerful being!

The travelers then began to break camp again and during this time Silverlark asked Puru and Calata if they knew anything of The Oracle Of The Fountain that was farther Northwest in the region of nameless hills where the Cyclopes roamed. Both the Leader and Interpreter had heard of the oracle but none of their group had ever visited it. The Wixaerd told them he had been reading the Book Of Symbols ever since he had found it and that there was something obscure written in the pages about the first Wixaerd being destined to visit the oracle. It said that The Oracle Of The Fountain would teach him a new and powerful language designed for his race known as Wixaerd tongue.

The Aborigines were excellent trackers and accepted the task of leading the Wixaerd to the oracle. Having packed up their belongings the party started heading in a Northwestern direction towards the vicinity shown on Silverlark's map of the area to be the location of the fabled oracle.

Slightly a month after they had left Watchalls they came within sight of the mysterious nameless foothills. Even from a distance one could see they were not shaped at all like the normal hills. Instead, they were grotesquely odd rock formations that had been formed by the erratic currents of wind, rain and dust in that area over eons of time. As they traveled on and got closer they could see just how bizarre the caricature of these hills was and wondered about a pass through them to the site of the oracle.

Eventually, they did discover a pass and entered into it and continued traveling along in a generally Northern direction although the pass twisted around the rock formations somewhat. After two weeks of monotonous traveling around the hills it seemed as if they were merely going in circles and then they came upon a canyon where there was a fissure in the ground in a circular shape filled with clear, aqua blue water.

Puru spoke quietly to the Wixaerd and told him that to the best of his knowledge this was the site of The Oracle Of The Fountain and Silverlark agreed for it was unnatural in appearance to its surroundings. The Aborigines stayed back while the Wixaerd approached the pool and looking into its depths he could see the root of the Arborstar that emerged within it and he was certain this was the oracle.

Then he spoke in a loud and commanding voice, "Oh great oracle! I am the first-born Wixaerd of Hearthorn of The Enchanted Isle and I have come to seek your guidance and wisdom ... show forth yourself unto me!"

With that the pool began swirling around and bubbling and frothing and soon in the middle of the pool a geyser of water gushed forth upwards and in its midst appeared the strange apparition of the oracle.

It spoke to him in the language of Man and said, "That I have awaited your arrival is true and I bid your companions leave you here with me for a time that I might instill in you the greater knowledge of Wixaerdry! For I shall reveal to you the secret of Wixaerd tongue and far more powerful understanding of your abilities."

The Aborigines gestured to the Wixaerd and retreated back into the pass they had entered from and Silverlark was left alone with the oracle. When the Aborigines were totally out of sight The Oracle Of The Fountain began singing in a strange, melodic voice that made the Wixaerd drowsy and soon he fell into a deep trance. When he awoke it seemed as if it had only been a moment's time and yet the sky was dark, whereas when they had arrived it was midday and he knew that substantial time had passed while he was under the spell of the oracle.

He instinctively knew the language of Wixaerd tongue now and many other spells and incantations were ingrained in his knowledge and the thought of all this sent a thrilling tingle of excitement through his whole being.

He turned and walked slowly back towards the path that led to the Aborigines and when he reached them Puru was concerned when he said, "Silverlark! We were becoming alarmed that you might have met your demise ... but you seem to be in fine condition!"

The Wixaerd replied that he knew he had been there for some amount of time perhaps all day and was astonished when the Leader told him that he had been absent for nearly two weeks. He told them of the wisdom the oracle had instilled within him and realizing that he was famished requested food and ate a large portion before he was fully sated.

Silverlark then told the Aborigines that the oracle had even given him the ability to control the Worms Of Fire named Draques such that they would obey his commands and they were truly astonished for no one had ever been able to approach one of these creatures without being engulfed in its flaming breath and being incinerated immediately.

He explained that he now wished to visit Boulderidge and meet with Draquekind. Puru told him that since they were near Elforest it would be quickest to head towards there and find the Elves residence of Hidever, although by its name this would not be an easy task. From there they could request passage aboard one of the Elf ships headed North on Noriver and sail around the coast to Boulderidge instead of traveling on foot.

According to Silverlark's map Hidever was situated in the midst of Elforest on the Western side of Noriver and this seemed to be opposite of the direction he was planning to head in. Yet Puru assured him that although it would be more time consuming it would be much easier by ship to sail the sea and Silverlark would also know the location of the Elves in this immense forest for future reference and he agreed to this plan of action.

They traveled along to the West for just about a month and then they could see the immense trees of Elforest ahead of them in the distance. Continuing on they reached the forest and entering it began traveling along between the trees. Soon they were surrounded by the massive growths that reached hundreds of feet into the air. The treetops were completely covered with limbs full of leaves and even during the day they were under a dim, green canopy as they moved along. There was also a great deal of underbrush and the Aborigines used machetes that they had to hack a trail through the jungle-like growth.

After a month of grueling travel they finally reached the shore of Noriver. Here the banks were wide apart from each other and free of undergrowth so that the travelers could go along the Eastern shore of the river in search of some means of crossing to the Western side. Puru told Silverlark that there was a good chance that they would not have to travel much farther until they reached an Elfindock.

This was true, for only three days after traveling in a Northern direction that was downstream on Noriver they sighted a dock with a large rowboat tethered to it. It was big enough to accompany all the party members and they got into the boat and rowed to the other side of the river. Once they had

reached the Western side of the river they tethered the rowboat at the adjacent dock on that side and got out and headed Northwest into the forest. Once they had entered the forest on that side of Noriver they again were required to chop their way through the impending underbrush and they made their way along slowly, day by day.

After two weeks of travel they came to an area in the forest where the treetops were curiously intertwined as if by some inexplicable method. Puru told Silverlark that this area was the home of the Gnomes of Weatherb who the Aborigines were ancestors to. Then he explained that the Gnomes had the uncanny ability to cause the limbs of the trees to grow in this manner to provide them with quick means of traversing the forest.

The party continued under the canopy of interlaced limbs in hope of finding a Gnome there that could guide them to Hidever. Then after another few days of travel they saw something approaching them and moving quickly through the net of limbs at the tops of the trees.

Soon the arboreal traveler was within close proximity of the band of travelers and hailed them, "Hello! I am Glitmag the Gnome ... I see you are those of the race of my forefathers although I do not recognize he who is a stranger among you. I say there my friend ... who might you be?"

Puru immediately addressed the Gnome and told him that this was the Wixaerd of The Enchanted Isle and that they sought the home of the Elves residence of Hidever and their aid in traveling by ship to the Southern area of Anotherealm. The underbrush had grown thinner in density when they came upon the Gnomes territory and Glitmag aided them by telling the party to keep careful watch of his movements as he guided them through the forest.

The Gnome then began traversing the network of limbs and gesturing occasionally to the travelers to follow and they soon were in an area where the underbrush had been eliminated by the Elves and this allowed the company to continue their journey unimpeded.

Within a few weeks of time they had arrived at the gates to Hidever, although due to the abundant amount of floral growths over the complex it was nearly indistinguishable even though they were at the very gates of the home of the Elves there. There were two guards at the gates who immediately addressed the group and Glitmag assured them that these were very respectable persons, among who was a Wixaerd and the guards hastily opened the gates and allowed the Aborigines and Wixaerd entrance.

Glitmag bid them farewell at their arrival to Hidever and vanished into the highway of tree limbs. The guards had instructed the party to take the main passage headed West and this they did, noticing other passageways and rooms off the main one they were in. Finally they came to a large set of double doors with a knocker shaped like the head of a Draque on the right hand door and Puru took the handle of it and knocked on the door three times. Both doors immediately swung inward as they were opened by doormen and before them was a large round table, similar to the one the Elves of Everhavens had sat at.

Seated at the table were fifteen Elves and they had obviously been holding council. Puru introduced himself and the Wixaerd who they were staring at as if surprised. They had seen Aborigines before, but never someone like Silverlark.

The Leader told the Elves that they wished to obtain passage aboard a ship around the Western coast to Boulderidge.

The leader of the Elves seated at the largest chair introduced himself and the group with him and said, "I am Gethro, Elfcaptain and these are my crew members: Aramor, Ganolynn, Timolar, Fabriel, Gwendyl, Thameron, Pereus, Terry, Garwynn, Shemach, Galitor, Milliron, Tolitor and Emilon. It is your luck that just by coincidence we were discussing a journey to Mountowers at this very meeting."

There were numerous extra chairs at the large table and Gethro bid the travelers to be seated accordingly. Once the group was seated Puru told the Elves of their meeting of the Wixaerd in Sandesert and their journey and his encounters with the Man O'Saur, the Wareacher and The Oracle Of The Fountain. He also mentioned the desire of the Wixaerd to meet with Draquenekind and the Elves looked upon Silverlark in awe.

Gethro spoke to the Wixaerd and said, "So ... you wish to travel unto Boulderidge and meet with the Draques! No one has ever been so bold before ... even we Elves with our most seaworthy Sea

Horse ships shun from crossing those areas frequented by these immense Beasts for fear of them. But if your Wixaerd tongue can tame such as these then you have our blessings. We will transport you to Mountowers for we are about to depart for there to have commerce with the Dwarfs, but you will have to excuse us if we do not accompany you to Boulderidge for we have no plans to sail that far on this trip."

When they had finished the conference and adjourned the meeting the crewmembers accompanied their guests to the storage area where they all obtained supplies and then with the Elfcaptain as their leader they left Hidever and headed for the great Norriver where the Elves ship was docked. The path they took was well used and cleared of underbrush and it was a pleasant journey to the ship. When they reached and boarded the crew took up anchor and the ship headed downstream to the North with the current aiding it.

After a little more than two weeks of travel down the Norriver they came to the bay of the Northern Anotherealm Sea. Leaving the river, they headed in a Westward direction along the coastline of the continent. The wind was in their favor and once the Elfcaptain had the crew hoist the sails the ship cleaved through the waters with greater speed.

After about another two weeks of travel in that direction they began heading to the South and it was about a month of sailing before they sighted the Western shore of Sandesert. Then Gethro gave instructions to steer the ship towards the shore and they anchored not far from it and took two rowboats with all the passengers aboard them and rowed until they arrived at the beach.

Leaving the boats everyone began walking towards Mountowers and since it was near the seaboard it was not long before they reached the Northwestern entrance. The Dwarfguard ushered them into the entrance and told them to take the tunnel that led South to reach Talletor who was in the central area of Mountowers at the time.

Gethro and his company were well known by the Dwarfs at Mountowers and the news of their arrival and the return of the Wixaerd spread quickly throughout the vast complex. The combined group of travelers was escorted to the tunnel that had one of the Dwarfs wondrously fast magnetic rail car systems and they boarded and began traveling swiftly through the passageway. It was not long before they had reached the main central chambers where Talletor was.

The chamber he was in at the time was much smaller than his own private one although still large enough for everyone in the party to enter. Talletor greeted the Elves, Aborigines and Wixaerd happily, especially Silverlark and then Puru told the Dwarflord of their journey and the amazing feats of the mighty Wixaerd. Silverlark then told Talletor of his wish to visit Boulderidge and the Draqunes.

To this the Dwarflord replied, "Yes ... it has been rumored for many years that such a thing as a DraquneWixaerd would come into existence. I wish you the best of luck Silverlark and may you be first to ride upon the back of a magnificent Worm Of Fire!"

The Elves remained for their bartering session while the Aborigines and Wixaerd continued traveling by magnetic rail cars until they had reached the Southeastern exit of Mountowers. They had picked up ample provisions and began their trek across the hot desert towards the East. Puru and company had decided to accompany Silverlark to the midst of Sandesert but the Leader told him that their group planned to head North at that point. The Wixaerd acknowledged this and assured the Aborigines that he was capable of making the remainder of the journey to Boulderidge alone.

They traveled slowly across the hot sands for about two months time and then arriving at an Oasis in the middle of Sandesert the Wixaerd thanked Puru and Calata and the rest of the Aborigines for their assistance and bid them farewell. From there he traveled in a Southeastern direction and hoped that it would eventually bring him to Boulderidge. He came to the Roundowns and passing through them came upon the Warplanes and the mighty Knotree. The Man O'Saur was there and he greeted it heartily.

Silverlark left the Warplanes and in another two weeks of time came upon the unbearably hot, steaming plains of Boulderidge. Traveling to the center of the crater there he saw the immense Southeastern Fyroot from which the Draqunes had come into existence. Silverlark went among the boulders there searching for Draqunepods until he finally came upon a nest of them. Then he settled

down next to the warm pods and awaited the return of a full-grown Draque to come and roll the pods over to keep them evenly warm.

The extreme heat in Boulderidge crater made the Wixaerd drowsy and he fell into a slumber. He awoke, startled at the sound of a Draque winging its way swiftly towards him. Looking up into the sky he saw the immense Beast approaching and as it did it belched forth fire and in the language of Man demanded that he leave the area immediately. Apparently the Draque considered the Wixaerd a threat to the safety of its nest of pods.

For the first time in his life Silverlark spoke the mystical Wixaerd tongue and commanded the mighty Draque to land next to him. The Beast soared down next to the Wixaerd and speaking once again in the language of Man told him its name was Quallselmium. The Draque told the Wixaerd that it and others of its kind had visited the future through the vortex of a time portal and knew of the coming of his kind.

Silverlark then requested that Quallselmium let him mount and ride upon its back and have it return him safely to his home of The Enchanted Isle and the Beast was obedient and knelt to allow the Wixaerd to climb on its back. With a chilling shiver of excitement coursing through his entire being he mounted the back of the Draque and then the first DraqueWixaerd of the world took to the air upon his Worm Of Fire and proudly flew off into the sunset of that ancient, legendary time ...

The Adventures Of Azureone

Once, many thousands of years ago on the continent named Anotherealm there was a very unusual creek. It flowed in reverse of all bodies of water upon the continent for instead of flowing to the sea, this was actually the ocean flowing inland through a small delta on the bay and on into a creek. At the seeming end of the creek was a vast pool where the water spun in a whirlpool and sank into a sinkhole in the Anothearth. For this reason people called it ... Endlesstream.

A few miles from the mouth of the stream was a village and near the creek in the same area lived a Gentleman in a cottage who was a solitary person for he had infrequent contact with the villagers. He provided for himself from the earth with a garden and also owned a fair sized herd of Sheep.

There was a wooded area near Endlesstream and one Spring day while tending his herd in this vicinity while they grazed on fresh Grasstalls he heard the cry of a babe in the direction of the creek. He hurried to the water's edge and there, hidden among the Waterushes along the bank was a hamper woven of strange reeds of some sort he had never seen before.

In it lie a child swathed in a royal blue cape with pure gold embroidered in the form of cryptic Symbols around the hem and borders. The Man took the child to his little cottage and cared for him and fed him the milk of his Sheep and in time the babe grew to be a young boy.

By the time he was old enough to accompany the Gentleman on outings to the village this Man had told him that he was a distant relative who the boy was under the care of. For all practical purposes the villagers gleaned this also.

The robe that the Gentleman found the boy as an infant in he stored in a trunk with Frankincense and Myrrh to keep it fresh. In his wisdom, he kept the knowledge of this powerful object and its portent a secret from the boy until he became an adult himself.

The Gentleman had taken the wool of his sheep and spun them into thread and yarn with his spinning wheel and dyed the woven material of the finished sewn clothing for the boy in Blue Bulberry juice and had told him that was his given name ... Azureone.

As the boy grew older he became extremely adept at his arts and crafts himself for the Gentleman taught him everything he knew and the older the boy got the more extraordinary he seemed for his abilities. He took the wood of the trees in that area and crafted his own Lute. With the music he created he was able to control the movement of the herd of Sheep and this astounded the Gentleman. He took the remedies that he had learned from his teacher and improved upon them and had wonderful elixirs to rejuvenate oneself with.

When the Gentleman himself became older in his years he finally told his ward the truth of his discovery in the creek. He brought the robe out of the trunk and offered it to him humbly as the old Man told him that to the best of his knowledge this was of his birthright.

By now the boy was extremely proficient and out of respect for his mentor, as instructed by the older Gentleman's advice he had been solitary and reserved socially. The old Man had finally visited the Sage who lived in the village and was told by him of an obscure ancient prediction that spoke of such an occurrence and that the person in such a basket in the reeds would be a Wixaerd's apprentice. The old Man told him that to all that he knew of proof of the cape and the younger Man's abilities was that he must be of the famed line of Wixaerds.

Thus, under the advice of the Sage the old Man told Azureone that he was undoubtedly a Wixaerd and that he had immense powers yet unknown to him that he should educate himself in to be wise and benevolent and share his abilities with the world. Azureone was then advised by the old Man to visit the Sage himself and this he did and was given advice concerning the prediction.

The Sage said, "It was written many hundreds of years ago on parchments that were my mentor's records that a Male child swathed in a blue cape of the line of Mystics would be found in a ship of reeds where the sea has no end ... he would be nurtured by Mankind and not Wixaerds ... he would travel unto The Oracle Of The Fountain and gain teaching of Wixaerd tongue and unto Enchanted Isle and from it gather a Staff Of Might Of Heartherb. It stated that the Wixaerds would do this so Man might teach and raise one of them so that he who was their student would have an even greater understanding between Man and Wixaerd."

The Sage continued and said, "Wixaerds have always returned to The Enchanted Isle after visiting the mainland. That is their inherent homeland. All that Man knows of Wixaerdry is what is practiced by such beings of power and then these same return to their island. All that Wixaerds know of Man has been taught them through the practice of miracles to aid him. For one such as you to reside with and have been tutored by a Man is a momentous occasion and the joyous combining of forces."

Azureone returned to the old Man's cottage and told him of the Sage's prediction and the elderly Man suggested that he explore the many wondrous sights of the world and find his destiny. Thus, with the strongly recommended advice of the Sage in agreement also, Azureone left the cottage in the able hands of his elder who was still in good health and began his journey in life as a Wixaerd.

He was provided with maps of the continent and a Compass for direction and a guide to ensure he be able to locate the more frequented paths and routes and also the difficult to find (though easier and quicker) passes through The Mystic Mountains. The guide had been instructed to take him first to the location of The Oracle Of The Fountain. This, the guide told Azureone would be the first and most difficult of tasks he must perform in order to obtain further knowledge of his powers.

The guide told him that he knew of the general area of the location of the oracle but not its exact position on the maps and thus, they would have to search for it once they reached that area. He knew it was located in the nameless hills of Edgeery Wastes and had been to The Wastes before but he told Azureone that there were many canyons within the hills and any one of a number of them could be the one containing the oracle.

Few had ever been known to find it, with the exception of Wixaerds. Azureone and the guide examined the huge map of the entire continent of Anotherealm and the guide showed him that the location of the village they were departing from was on the Southeast side of The Mystic Mountains on the Eastern side of Whitheriver where the Glowood Forest met the valley before the mountains.

They both had ample provisions to take with them for the journey and would have to cross over the mountains and then travel through the Edgeery Wastes. These areas were the known territory of Wagglers and Wareachers and journeying here would be risking an encounter with one of these beings. The two travelers set out and began crossing down into the lush valley before the foothills of The Mystic Mountains headed North. There were ample fruit trees and berry bushes growing in the valley and Azureone knew this area well within its limitations.

Since this was the beginning of their trek they both took their time of leisure to stop in the valley while crossing it to enjoy its benefits. Azureone informed the guide that he wanted to make certain he had various of the herbs and certain dried fruit tree leaves for medicinal purposes. These he picked carefully and in the days that they were in the valley he dried and cured the necessary ingredients for some very potent antidotes in case of emergency.

Once they had left the valley they began entering the foothills and experiencing an increasingly sharper uphill incline as they approached the majestic Mystic Mountains. Upon entering the mountain range the guide removed a map from his backpack that showed the nearest entrance pass on the Southern side of the mountains. According to what the map showed they would have to cross through certain ravines and canyons in order to achieve arriving at the North side of the mountains.

So for days they traveled up and down across the mountains and into the crevasses between them before finally reaching the last mountaintop they climbed to on the Northern side of The Mystic Mountains. Then they looked down into the valley below them at the lush, magnificent Meadowoods forest.

They began their descent into the woods and had not traveled very far into the forest before they were confronted by a very strange being. They were traveling along one of the trails shown on a map the guide had and had just turned a corner when there before them in the path stood a Sylph.

She approached them and said, "Hail travelers! Especially you in the blue robe who appears to be a Wixaerd. What prevails that you would grace me with the presence of your company?"

Azureone spoke warily and said, "I seek The Oracle Of The Fountain far North in the Edgeery Wastes ... that is my destiny."

Then he and the guide continued on past the Sylph as if ignoring her, yet maintaining their distance in case she was aggressive.

The Sylph spoke to them as they passed by and said, "I can get you there to your destination much faster if you wish my assistance in the matter."

Azureone stopped and turned and said to the Sylph, "Tell me ... by what means is it faster to travel than as we do now?"

The Sylph smiled at the travelers and then reaching into the small pouch with its shoulder strap that she had she removed a small, silver colored metal whistle and put it to her lips and blew into it and it made a shrill, high pitched sound.

Azureone and the guide looked at each other in wonder as to what the Sylph had summoned. Soon they heard the sound of more than one set of Horses hooves galloping towards them in the distance and then there approached them three Stallions that stopped next to the Sylph and she began talking to them in a soothing voice and petting each one of them fondly.

Then the Sylph told Azureone and the guide the names of the Horses, "This white Steed is known as Swiftwind and the brown one is Windracer and this magnificent black Stallion is named Steedfire and these are fine mounts that can make quick transport to your destination."

Then the Sylph added, "I would be more than honored to accompany you both on this part of your journey. I am well acquainted with the Edgeery Wastes and could be of beneficial resource to you."

Then the Sylph told them her name, "My name is Balimus and I have lived in Meadowoods most of my life. I came originally from The Garden Of Delight from the limb of Farmint of The Tree Of Life, the Arborstar ..."

She continued saying, "Where you plan to travel there is the possibility of danger. The Edgeery Wastes are inhabited largely by Wagglers and Wareachers. I know of various routes through that area that are safer than others."

Azureone spoke concerning the matter, "Yes ... my mentor told me of just such facts that you have mentioned. But it is nearly directly North to the location of The Oracle Of The Fountain and I was told that the malevolent creatures are scarce in that area."

The Sylph then said, "This is true ... their main residence is at Watchalls in the Northeastern area of Edgeery Wastes, but they have been sighted near the lost mountains where the oracle is."

They set out the next morning after a night's sleep and continued traveling for three weeks on their Horses at a fast pace stopping only to rest at night. Then they came to the edge of Meadowoods. As soon as Balimus cleared the forest she took off on her Horse at a full gallop and Azureone and the guide followed in her wake. As they were racing along Azureone noticed that the ground was becoming more moist and mossy the farther they traveled. The bushes were growing thinner in density too as they progressed farther into the Edgeery Wastes.

When they stopped for the night on the edge of the Wastes Azureone began gathering branches and sticks from the sparse bushes in their vicinity and Balimus looked at him curiously and asked what his purpose was. Azureone told her he had planned to start a small campfire to keep the chill off for the night and Balimus said, "It would be wiser not to build a fire ... it would be seen for miles in any direction and although we are not yet deep into the area of the Edgeery Wastes it might attract those creatures that are not so favorable."

Azureone reluctantly dropped the bundle of wood he had collected and went over to stand next to Balimus with the guide. It was a cool night with clear skies and the stars were shining brilliantly. The three of them each had a small portion of dried food for a meal and then they retired for the night. It was not as warm as they would have liked but still bearable. Azureone awoke a few times during the night to the howl of a Coyote in the plains but there were no confrontations.

They proceeded on their Horses and kept them running rapidly, stopping occasionally to let them rest and forage. At night they took turns on watch for they were now near the edge of the nameless hills and the possibility of meeting a Wagglor or Wareacher was much more likely in this vicinity.

When they reached the pass that the Sylph knew to be the entrance that led to the location of The Oracle Of The Fountain they stopped their Horses and Balimus said, "I suggest that your guide remain here while you proceed. It is known that few individuals have ever been able to locate the oracle and those were usually Wixaerds like you. As you have said, it was predestined that you meet

with the oracle and it will be better if you do so alone so that no one imposes, to ensure that you receive whatever guidance it may provide you with."

Then Balimus reached into her pouch and withdrew a small bag and handed it to the Wixaerd and said, "This is the dried powder of the Farmint fruit of my people. If you should chance upon a Wagglor or Wareacher sprinkle a small amount of it upon them and they will appear as they really are ... remember, these beings are Xenomorphs; shape changers and can appear as beautiful creatures. The powder will transform them back into their real personages."

Then Balimus got on her Horse and bid the guide and Azureone farewell and galloped off across the plains, heading back to Meadowoods. Azureone put the sack of Farmint powder in one of his inner robe pockets and mounting his Horse waved farewell to the guide and headed off slowly into the pass into the nameless hills. As he traveled he noticed how very much different the rock formations of this area were in contrast to what he had witnessed before. They seemed almost as if to be hewn by some gigantic sculptor in abstract forms.

He traveled until nightfall and although Balimus had warned him against building a fire he decided to make one anyway to ward off the chill for it was colder here in the Northern regions. There were very few bushes and shrubs around and he managed to collect enough for a small fire. He arranged the wood into a small pile and then withdrew his tinderbox from the pocket where he kept it in his robe and igniting the wood soon he had a small campfire blazing and he sat in front of it warming himself. He had not been there long before he heard the Horse that was near by whinnying and stamping its hooves.

Then he was startled to hear a voice directly behind him and turning quickly he saw a beautiful Woman who said, "Hello! You must be a stranger in these hills. I've never seen you before."

She was very close and thinking quickly about what Balimus had said about the Xenomorphs in this area he reached into his robe pocket where the Farmint powder was and scooped a small amount into his hand.

Then in order to distract her he said, "Why ... I just came from over in that direction."

He pointed in the direction behind her and she turned around to look. Then he quickly came up behind her and sprinkled the powder over her head.

Instantly before his very eyes the Woman changed into an old hag and screeched at him, "Yaaah! You are a Wixaerd! What other tricks can you play upon me? I must flee before you completely dissolve me!"

Then she ran off down the pass and away from Azureone. The Wixaerd was startled by this occurrence and then quickly extinguished the fire he had built to avoid attracting any more such beings. Then he decided to mount his Horse and ride even though it was dark of night. He rode until break of day and then exhausted climbed off the Horse and laid down to rest.

When he awoke it was shortly after noon for the Sun of Anothearth was just in its descent from the middle of the sky and Azureone mounted his Horse and continued down the pass. It wound around and it seemed as if he was not going to be able to locate the oracle and then when he had just come around another turn there before him was a placid pool of water of the most astoundingly azure color.

Getting down off his Horse he walked up slowly to the pool and spoke in a commanding voice, "Oh great oracle! It is I ... the Wixaerd in blue who has come to you. I ask of you to aid me in my quest!"

The middle of the pool began frothing and Azureone arose and stepped back hesitantly as a column of spray formed in the middle of the pool. Then in its center appeared the visage of the oracle.

It spoke and said, "I have awaited your arrival as was predicted and now that you are here I will impart to you the knowledge of the powers of Wixaerdry such that you may use them for the benefit of all!"

Then Azureone listened as the oracle continued speaking and he began to fall into a trance. The oracle spoke to him of the various floras of the great Tree Of Life, the Arborstar and what each one could be used for. Some were for spells of healing, some for spells of invisibility, others to ward off horrid spirits and there were any number of a great deal of incantations, the knowledge of which it imparted to him. When Azureone awoke from the trance he was filled with an overflowing, seemingly endless abundance of information concerning the arts of Wixaerdry.

The oracle was still present in the column of spray and it told him to dip his hands in the pool and when he did he realized instantly that his memory of all that it had given him would never fail. Once he removed his hands from the water the oracle vanished back into the pool. Also what the oracle had told him of the Heartherb wand was of great importance to him now that he had the wisdom of the incantations because some of them required the wand in order to be performed.

Azureone went back to his Horse and mounting it, sped swiftly away towards the opening to the pass where he had left the guide. When he reached him and told him the news of his newfound prowess the guide merely smiled and nodded his head in acknowledgment. Then Azureone told him they must make their way to Enchanted Isle so that he could obtain a branch of the Heartherb to make into a Whitherwand.

The guide and Azureone looked over their maps and decided on the most expedient route to take to reach the island. They would have to return through Meadowoods and cross the Noriver and the guide told him of an area on the river where there was a waterfall that would allow access behind it from one side to the other of Noriver.

They journeyed back along the same path they had taken to reach the oracle and passed on through Meadowoods without any confrontations. When they reached the vicinity of The Mystic Mountains where the Noriver ran from it they rode towards the mountains along the Eastern bank looking for the waterfall. When they did find it there was an accessible area behind it that they rode their Horses through and then they continued traveling West along the foothills of the mountains.

Here there were abundant fresh fruits and berries for their sustenance and they stopped frequently to enjoy these. Finally, they reached the pass that led up through the mountains and to the Southern side of them. They continued on until they had come down out of the mountains and into the rolling hills named the Roundowns. The guide suggested that they head back in an Eastern direction towards where the Whitheriver on that side of the mountains was in Glowood Forest and attempt to locate the home of the Elves there named Everhavens. Once they found the Elves they might be able to persuade them to provide passage to the island aboard one of their Sea Horse ships.

They traveled for a few weeks to reach the forest and then entering it continued on in the direction that was indicated on the maps to be the location of Everhavens. It had been only a few days that they were traveling when they saw something near a small brook that was close to the trail they were on. The guide informed Azureone that this was one of the Nymphs and that he should proceed with caution. Azureone had obtained some of the Watersweet leaves that had been dried and ground into powder and was believed to be used to prevent a Nymph from overpowering someone.

The guide remained at a distance as the Wixaerd dismounted from his Horse and then walked casually over to the Nymph. When he approached her the scent of Watersweet she emanated was almost overpowering and when she saw him she looked fondly at him and offered some of the elixir itself. Knowing that it was a highly potent euphoric in its natural form he reached quickly into his robe pocket where he had the powdered Watersweet and grasping a small handful brought it out and quickly blew it into the face of the Nymph. She sneezed and then looking dreamily at the stream no longer seemed interested in the Wixaerd. Azureone returned to his Horse and he and the guide rode on past the Nymph and continued their search for Everhavens.

After three weeks of diligently searching the area where the home of the Elves was supposed to be, they finally located it. Upon approaching the gates an Elfguard hailed them and they told him of their intentions and were admitted into Everhavens and instructed to seek the Elfcaptain Franderos whose ship was anchored nearby on the Whitheriver.

After questioning various of the inhabitant Elves of the residence they finally located Franderos and spoke with him. He told them he had just finished obtaining provisions for his next journey down Whitheriver and although he intended to sail around the Western coast to Mountowers, the home of the Dwarfs, he agreed to change his plans and transport the Wixaerd and his guide to the isle and then return them to Everhavens.

Franderos and his crew gathered their provisions and with Azureone and his guide slowly cantering their Horses alongside the Elves on foot they made their way to Whitheriver and the ship that was anchored at the dock there. When they reached the ship Azureone and his guide left their

Horses and boarded the ship and the captain gave the order to take up anchor and begin heading the ship downstream. The current of Whitheriver was very rapid and with the additional aid of the ship's sails they made quick time in reaching the sea.

Then the ship was turned to head West along the coast and on to Enchanted Isle. The journey to the island took almost three months time and during this time Azureone occupied himself with writing down as many of the spells, incantations and potions that he could on parchments the Elfcaptain's scribe provided for future reference.

When they reached the bay of Enchanted Isle the captain ordered the ship to be anchored and Azureone was escorted to its Northern shore by a small crew of the Elves in a rowboat.

Once reaching the island and using the map of it that he had been provided with, he soon located the Heartherb tree and selected a fine, straight branch from it to fashion into a wand. Then he returned to the beach where the crew awaited him and they all made their way back to the ship in the rowboat.

In the time it took to sail the sea and return East to the Whitheriver Azureone had carefully prepared his Whitherwand and had written additional parchments containing very potent spells. When they sailed up the Whitheriver and docked to return to Everhavens Azureone and his guide went with them to visit for a short while and enjoy the comforts of the home of the Elves. There the Wixaerd practiced his first Whithering with his wand to the astonishment of everyone and placed a Spell of Protection upon Everhavens such that no harm should ever come to the Elves there throughout eternity.

Then Azureone and his guide decided it was time to return to the little village they considered home and having ample provisions provided by the Elves they set out on foot, since they had freed the Horses before leaving for the island.

When they reached the village the first thing they did was visit the Sage who was extremely proud of Azureone's accomplishments and told him he would always be welcome at the Sage's humble abode.

Then the Sage looked at Azureone for a long time without speaking and then finally said, "It was I who placed you in the reed basket there at Endlesstream so many years ago ... you were but an infant and born to fulfill the predictions of Man and Wixaerd and now that this is accomplished the whole world will rejoice and be gladdened at having one such as you living in their midst."

Azureone thanked the Sage and the guide for all their assistance and then returned to the cottage of the Man who had raised him. He told him of the events that had occurred in his absence and the Sage having revealed his true origin and that he would live with the Man to continue to help him with all he had learned and so for the first time in all history a Wixaerd was known to remain among the company of Humankind ...

Fable Of The Knight Of Toast

Very long ago, when the continents were as one and called Anotherealm, there was a great kingdom of Men in the central Western region on the Northern side of The Mystic Mountains in that forest named Hollowoods.

The King who ruled there was wise and benevolent and his fortress was named Earthalls. Near Earthalls to the North was a huge body of water named Bowlake and around it were numerous villages. One of these was named Hoborough ...

There lived near Hoborough a family who owned a small farm and unto the Man and his Wife was born a son who was named ... Gamelad.

The father of the boy was industrious and worked the fields growing vegetables and providing cattle and other stockyard animals for the family's sustenance. When the boy became old enough he began assisting his father with the chores on the farm. Then when he became dependable enough his father would send him to the local grocer with their finest cuts of meats to barter for other goods. Gamelad became competent and eventually the grocer hired him to work in the kitchen of the restaurant that the grocer owned there in Hoborough.

Gamelad was kind hearted and out of his own pay he would provide nourishment to those less fortunate and served them soup and bread every day. The King of Earthalls, good Arcturius heard of Gamelad who was called Chef Of Hoborough and decided one day that he would visit the kitchen of the lad to sample his cooking, for he had heard that Gamelad made delicious meals.

When Gamelad heard the news that the King was going to visit to sample his cooking he prepared a very sumptuous meal for him. When the King dined upon the feast presented before him he was impressed and welcomed the lad to become Chef at Earthalls.

Gamelad was delighted and told the King that as long as he would provide a relief cook in his stead at the kitchen to continue to provide for the folks who ate there he would be more than grateful. This, the King gladly did for he was a kind monarch.

As time went by and he worked in the kitchen of Earthalls and reached Manhood he became renowned for his cuisine throughout the land. The King had him instructed in the art of hunting wild game and gave him a shining suit of armor, a shield, crossbow and sword and a magnificent Stallion. Upon the shield was cunningly wrought a goblet with Serpents entwined about its stem. The King dubbed him Sir Gamelad, Knight Of Toast.

He would hunt for delicacies that he would then prepare for his King's court to the enjoyment of all. Sir Gamelad also found it enjoyable to visit the wilds of Hollowoods for his hunting expeditions and on one occasion in particular he had been tracking his prey for a lengthy period of time. A number of days had past and he was approaching The Mystic Mountains. He continued to follow the tracks of the Buck Deer he was after and they led up into the mountains.

When nightfall came Sir Gamelad found himself well within the mountain range and he began looking for a place to camp for the night. He started searching about along the mountainside when he saw a cave that looked like it would be a suitable and safe place to rest for the night. He entered the cave to inspect it and immediately noticed how dark, damp and musk smelling it was.

There was moist moss growing inside it on the rocks and it had obviously been in existence for many centuries for there were projecting stalactites hanging from the ceiling and stalagmites growing from the floor of the cave. He searched around until he found a piece of dry Touchwood and then using his tinder box lit the wood to use it as a torch to get a better view of the inside of the cave.

Once the stick was burning brightly he could see a large pot suspended by chains from the ceiling at the back of the cave and below it was the remains of a fire in a circle of stones. He went up to the pot and removing the lid it had he bent over to peer inside and see what was in it. When he did something hit him in the back of the head and he saw stars momentarily and then lost consciousness.

When he awoke he had a terrible headache and when he tried to move he found that he had been bound in some of the vines that grew in the cave. He struggled, attempting to free himself and then he noticed that the fire under the pot had been rekindled and there was a huge and ugly Troll looking

at him hungrily as it stirred the contents of the pot. Off to the side of him out of reach he saw his crossbow, shield and sword lying on the floor of the cave.

Sir Gamelad thought quickly of a ploy to free himself and looking smugly at the obnoxious Troll he said, "Well! This is a fine way to treat a Knight and the finest chef in the world! I would rather the cooking of your meal myself do ... than to eat up a poorly prepared meal. At least I know the proper means of making a decent stew that will be tasty to your palate ... see there? Look at my shield with its goblet entwined with Snakes ... that should speak for the true mettle of my worth!"

As Sir Gamelad had anticipated the Troll was exceedingly stupid as well as greedy and he came over and untied the Knight and started shoving him over towards the pot.

Once again Sir Gamelad thought quickly and said to the Troll, "Say ... I'll need my broadsword to cut meat up you know! Being a chef and all ... I know how to make the tastiest cuts of meat!"

The ignorant Troll went over and picked up the sword and took it over and handed it to the Knight. Once Sir Gamelad had the sword he struck the Troll directly in the forehead with the hilt of it knocking the despicable creature unconscious. Then he bound the Troll with rope that he had on his Horse's saddle and when the Troll awoke he found himself tied up tightly with the end of the length of rope strapped to the saddle of the Knight's Horse.

Sir Gamelad mounted on his Horse led the Troll back to Earthalls and the King imprisoned it so that it might do no further harm to anyone. It had been a number of years that the Knight had been in service to the King and in that time he had heard a tale that was told of the King's daughter having been captured by pirates of Bowlake who themselves fell prey to the Gorgolyte. It was rumored that the Gorgolyte had enslaved the Princess and bound her face about her eyes with a blindfold so that she would not turn to stone as others had done who looked upon its countenance.

The Queen of Earthalls was told to be in mourning since that awful occurrence and no one had seen her appear, even for ceremonies. Sir Gamelad asked for a private audience before the King and when it was granted he asked discretely of the matter concerning the Princess. King Arcturius confirmed the report of his missing daughter although he could not say where she was.

The Knight humbly requested an indefinite leave of absence to search for the Princess and the King granted him his request. Sir Gamelad took to his mount and headed North from Earthalls towards Bowlake. It was not that far away and after a few days travel he reached the lake. Traveling West along the lake's shore he soon arrived at the nearest village that was called Beachaven.

It consisted of shacks, shanties, warehouses and the occasional inn, most of which were built upon wharves with docks beside them for access by ships. The Knight began inquiring about the village and discovered that there were two distinct classes of people inhabiting the village

There were the Wharfolk who were ships captains and crews and the Dockind who were the local innkeepers and their employees. The Knight rode slowly along the wharves asking around for any news concerning the demise of the Princess. It was common knowledge around the village that the King's daughter had been captured as well as the rumor of the Gorgolyte on the lake.

Yet, most those who he questioned were adamant to speak of the matter. Sir Gamelad finally entered an inn and ordered an ale and struck up a conversation with the innkeeper who told him that there was one particular Captain Sea Eyes who might be interested in assisting the Knight in his crusade.

Sir Gamelad returned to his Horse and rode along the docks looking for the ship the Wavecutter that was the property of the captain and once he found it he hitched his Horse to a nearby railing and proceeded up the gangplank to the ship's main deck. Then he went down the flight of stairs leading through the corridor that brought him to the captain's cabin and he knocked loudly on the door. It was immediately answered by a salty looking character with bright auburn hair and bushy beard and the most intense sky blue colored eyes the Knight had ever seen.

The captain immediately spoke saying, "Avast! Shiver me timbers! Come in Sir Knight! Scuttle me amidships ... but what would a landlubber like ye be doin' in these parts?"

To this Sir Gamelad replied, "I have come in search of the Princess of Earthalls, daughter of good King Arcturius who I am Chef and also a Knight for. Perhaps you know something about her and might aid me?"

Captain Sea Eyes told Sir Gamelad, "Aye ... every captain who sails a ship on Bowlake has heard about the capture of the Princess by pirates and then the Gorgolyte. As to which of them would venture near, I am the only one. If it be passage to there ye be lookin' fer, I'd be glad to help."

Thus, Captain Sea Eyes and Sir Gamelad went around gathering crewmembers to employ on the decks for the job. This was difficult for there were few Men who would venture near the territory of the Gorgolyte and they finally found enough Men to sail the ship, with the stipulation that they were not required to confront the Gorgolyte themselves.

When they had boarded the ship Captain Sea Eyes took the Knight to his armory and showed him all his arsenal which was impressive and among his weapons he also had Dwarfwrought, Lavasteel chain mail suits of armor far stronger than adamantine steel and feather light such that if one went overboard into the water they would not sink and he had Sir Gamelad change into one because his normal armor was heavy.

Once the ship was fully manned they set sail and headed directly for the Northern coast of Bowlake where the Gorgolyte had been rumored to reside. Once they reached the Northern coast they sailed West near the shoreline and after three days travel came to an area where there were high cliffs along the shore that were lined with numerous labyrinths.

Captain Sea Eyes set anchor next to one of the massive openings in the cliffs that was rumored to be the abode of the Gorgolyte. Then he went to his cabin and returned with two unique pair of eyeglasses.

He told Gamelad their purpose saying, "These too like the armor are Dwarfwrought ... if ye wears these spectacles ye will be able to look at the Gorgolyte without bein' paralyzed by its ugliness."

Then he went to his cabin again and came back with a medium sized mirror and said, "When we's finds this Gorgolyte Beast ye shows it the mirror and when it sees itself it will become as still as stone."

Then the captain, Sir Gamelad and a handful of crewmembers were lowered in a rowboat and began rowing towards the labyrinth entrance that was alleged to lead to the Gorgolyte. Once reaching the edge of the opening the captain and Knight got out and donning the protective eyeglasses entered cautiously into the entrance of the cavern. Once inside they found that there were mazes of tunnels, some of them interconnecting and the captain marked the walls of each one, as they searched deeper inside to make sure they would not be lost on their return.

As they neared one turn on the other side of it they heard chortling and hissing and a hoarse, raspy voice say, "Well my sweet! You will be forever bound blind or become petrified at my visage. I leave you to make my supper, but mind you! If I do not find it appealing I will remove your mask!"

Then they heard the Gorgolyte headed in their direction and as it rounded the corner the captain quickly raised the mirror he had at its face. The instant it saw its own face it shrieked and as the captain had said became frozen in pose.

The Men went around the corner to where the Princess was and Gamelad spoke to her quietly and gently removed her eye mask. She squinted and was unable to see at first but overjoyed with relief at being rescued.

The three went back to the ship and sailed back to Beachaven and by then the Princess had regained her sight and at her appearance there grew a crowd of people so very thankful that the Princess had been saved. Sir Gamelad took the Princess to Earthalls and the King and Queen were so happy that their beloved daughter had returned.

Eventually, Sir Gamelad and the Princess fell in love and the King and Queen threw a large ball for the reception of their marriage and such is the story of The Knight Of Toast.

The Goblin And The Pixy

Once ... long ago in a land that was called Anotherealm there was a myriad of strange and unbelievable creatures. One of these was an ugly, old, shriveled up Goblin born of the Knotree who lived under a dilapidated, moss covered, little wooden bridge upon the Whitheriver that had long gone into disuse because it lie so far off the main path.

It was not always so with the little bridge for in years gone by the Goblin remembered the fragrant scent of many a frequent passerby and he would await the trod of feet upon the bridge.

Then he would exclaim in his loud, hoarse voice, "Golly!" Then most of the time the unwary wayfarer would peer curiously over the bridge's rail to see who it was. Then the Goblin would thump them on the head with his club knocking them unconscious and taking them to a little cave in a hillside where he lived. He would enslave them for a period of time to do his bidding and clean and cook for him.

He had some pretty gruesome friends who would often come to dinner such as Harpettes, Trolls and Goblins and they started calling him Golly for a name because of the means by which he entrapped his prisoners. He remembered those days as good times for the hunting was excellent, but nowadays the best he could do was Seagull Turnstone stew because the area where the little bridge was had become desolate and no animals wandered by anymore.

Finally, Golly could take the meager meals no longer and one night he wandered out of his cave and down the path that led to the little bridge and when he reached it he gave a deep sigh, then turned and continued heading wherever his destiny might take him. Soon, Golly thought he smelled the scent of something tantalizing down the trail he was on and he hurried in that direction.

He arrived at a meadow where there was a herd of Sheep grazing on the grass and he muttered quietly to himself, "What a beautiful meal that flock O'Mutton would make ... if only me had me pot to stew 'em in!"

He figured the shepherd had to be near by somewhere and if he snatched a few of the flock the Man would show up to see what the bleating was caused by and Golly could enslave him too. So he raced into the herd and grabbed a Sheep under each arm and as they were bleating frantically he stood waiting the arrival of the shepherd because he was certain the noise would attract his attention.

Suddenly, Golly felt the earth trembling beneath his feet and right behind him he could hear something very large approaching through the trees that surrounded the meadow. As he turned around to look in that direction all he saw was a huge head with one gigantic eye right in the middle of the forehead peering at him and a huge hand swept down and smothered him. He felt himself lifted into the air and then the humungous being started walking away with him in its palm, as it took giant strides.

He could see through the huge fingers that surrounded him and Golly knew that the monstrous entity was headed for the mountains with the herd of bleating Sheep ambling along in his wake. Golly had heard tell of these colossal creatures in tales that his horrid friends had told around Golly's cooking pot, but he had always dismissed them as rumors or fables. Evidently he had been wrong for this creature must be none other than the one they had spoken of ... a Cyclops!

It was not long before they were well into the mountains and then the Goblin could see that they had entered a cave. The next thing Golly knew he was thrust into a gigantic cage hanging by a chain from the ceiling and the door was locked. Then the Cyclops went to the cave entrance and rolled a huge boulder in front of it and the cave was totally dark. The gigantic being lumbered to the middle of the cave and lit a massive fire there. As soon as the fire was lit Golly looked at his surroundings and there perched upon a ledge in the cave was a gigantic Vulture-like Bird that could only be ... the Roc!

Then the Cyclops went over to one of the dark corners and Golly could hear something jingling and see things sparkling in the firelight in that corner. Then the gigantic being went over to the Roc and Golly could hear him mumbling something in a deep, low-pitched voice to the Bird. After this the Cyclops returned to his business in the dimly lit corner.

Meanwhile to Golly's surprise the Roc spoke and said to him in a hoarse, croaking voice, "My master who is called Oneye says that he caught you trying to roust some of his herd, no doubt to eat. He has brought you here to be held captive until you stand trial and be judged for your crime."

Golly remained silent, cowering in his cage and wondering what horrid end these creatures might make of him. Soon Oneye came out of the corner carrying a gigantic kettle that he sat upon the fire and then filled with water and vegetables. Golly became frightened out of his wits that he might be the main meal. After the stew had cooked a while Golly could smell the aroma of the vegetables cooking and his stomach started rumbling. He had not eaten since leaving the area of the little bridge and he was famished.

Oneye went over to the kettle and picking up a small hollowed out stone ladled a small portion of the stew into it and brought it to the Goblin. He ate ravenously and he thought it tasted palatable even though it contained no meat. Meanwhile the giant Cyclops ate his massive portion and then went over and reclined next to the herd of Sheep to sleep.

Golly sat shivering in his cage for a long time and then when the fire finally died out he fell asleep. The Goblin awoke to the sound of the Cyclops rolling the boulder aside from the entrance to the cave and daylight streamed in. He went over to the Roc and mumbled a few words and the gigantic Bird swooped down off its ledge and out the entrance to the cave.

Then Oneye came over and picked up Golly's cage, removing it from the chain and strode out the entrance to the cave with it and rolled the boulder outside across the opening to keep the herd of Sheep contained. Then with Golly in his prison the giant strode off down the canyon they were in. It led directly to an area where there were two other Cyclopeses and the Roc gathered. One of the giants had a massive jewel encrusted crown upon his head and the color of his eye was blue, similar to that of Oneye. The other had a gray eye and when Oneye reached them the three Cyclopeses began talking in their deep, low pitched, indiscernible language.

When the gargantuan beings had adjourned their meeting the Roc spoke to Golly and said, "He with the gray eye is Stoneye, greatest of all gardeners in all the world ... the crowned giant is none other than Loneye, King of the Cyclopeses and this they have decreed to be your sentence ... you shall be leashed to the head Ram of the herd of Oneye, to be the herd's shepherd and care for it until at such time as you have proven yourself trustworthy in the sight of all."

So, Oneye carried Golly back to the cave the Cyclops lived in and leashed his neck with a metal collar to a metal collar on the neck of the head Ram. The Roc also gave him strict instructions for the grazing and watering of the herd and Golly was set upon a strict timetable. He was punctual and did his job to the best of his abilities and then Oneye became less and less concerned about Golly's whereabouts as time wore on.

Then one night when the Cyclops was fast asleep, snoring in the corner, Golly led the Ram over to the corner of the cave where Oneye often occupied himself with the glittering objects Golly had observed there from a distance since the Cyclops would not allow him near that area. What wonders to behold! The floor of that corner of the cave was covered with gold and gilded items. He searched diligently until he found a small falchion broadsword and tucking it beneath his tunic went back over to the rest of the herd.

The next morning, Oneye rolled the boulder aside from the inside of the entrance to the cave and Golly led the Ram and herd to pasture as he usually did. He took the Sheep down the canyon to the usual field where there was a stream of water for the flock to drink from and grass for them to graze upon. Then looking all around to make certain no one could see him he withdrew the falchion and striking the chain between him and the Ram, broke it and he began running as fast as he could go in the direction that led out of the hills.

Golly fled from the mountains headed North for many days and then he found himself in the barren wasteland as the Sun of Anothearth was just beginning to set. He slowed his pace and continued along until he noticed a peculiar aroma wafting on the breeze. It did not smell altogether delectable to him but whomsoever was cooking might have something else that was edible. He headed in the direction of the scent and soon, he saw a flickering light up ahead.

He crept up to it cautiously, hiding in the sparse bushes and then he could see that there was a coven of old crones encircled around the fire and above it was the kettle from which the aroma emanated as they chanted a horrid incantation:

"Beware the mists, and scalding cauldron,
Frothing, heaving, seething potion.
Brewed while Bats wing, eyed by Newt,
Tail of Snake shakes Mandrake root.
Bold as wild Beast, stamps the Ram,
Draquenefly soars, bleat of Lamb.
Tongue of Crow speaks, roar of Bear,
Finger pointing in the air.
Monkey's peek and jump of Toad,
Skulk of Rat and stance of Goat.
Gurgling marshes, tar and bog,
Here we circle in the fog.
Summon cowering, fear and dread,
Make the brash ones fear our tread.
Shrieking Gargoyles from above,
All that start shall turn and run.
Crackling firebrands they will see,
THEY WILL TURN TO RUN AND FLEE!!!"

Golly noticed that his little sword was glowing very brightly within his tunic where he had put it and the crones were cackling, haggling and arguing among themselves for their spell seemed not to have worked.

Suddenly, one of them espied the glow of the Goblin's sword and screeched, "There it is! That Hobgoblin has a Dwarf sword! It's ruined our brew with its nasty powers! Get it! Destroy it!"

Then all the hags began to head in the direction of Golly and he turned and fled as fast as his feet could carry him with the crones in close pursuit. As he ran along he withdrew his sword from his tunic and it began pulsing light brightly. Also off to his left he could see what appeared to be a Firefly in the distance following him. This he thought nothing of at the time for it was the crones he was most concerned with. After a short distance of following and screeching at him from behind the crones gave up the chase and Golly ran until he felt it was safe to stop.

When he did the tiny Firefly light came closer and hovered above his sword. Now he could see that it was a miniature Woman with transparent wings like those of a Mayfly!

She seemed to have no fear of Golly or his sword and undauntedly taunted him by saying, "A Pixy Queen is what you see ... so wishes three I grant to thee ... but say my name, now that's the game!"

The little Pixy danced impatiently on the tip of Golly's sword and glowing dust spread about the air from her tiny wings as they tinkled ever so softly and the sound of them astonished the Goblin.

Golly exclaimed, "Land O Goshen! It's a bell!" At this the Pixy was angry for she had misunderstood Golly and said to him defiantly, "So ... you have guessed my name of Itsabel and rightly so! But now you must gather your wits about you and answer a riddle for each of the three wishes to be granted you!"

Golly was surprised that he had gotten the name of the Pixy correctly by mistake and wondered what the other three riddles might be when the Pixy spoke again and said, "Here is the first riddle! Crawls on the earth ... hides before birth ... these are the things ... whose legs become wings!"

This made Golly very nervous for he had not a clue as to the answer and he dreaded crawling on his hands and legs on the ground as a penalty for the rest of his life if the Pixy should put a spell upon him. Also, he had not eaten since leaving the Cyclops and his empty stomach began to growl so that he said, "Golly! It's me's tummy! It's got to be the Butterflies!"

Now the little Pixy's face turned red with anger and she tinkled her wings madly as she said, "Now you have guessed the solution to the first riddle to be Butterflies which is correct! You may have defeated me once but you shall not do so again."

Then she said, "Here is the second riddle ... moves all around ... without a gown ... sails the seas ... talks to the trees ... where this thing goes ... no one does know!" Golly had been traveling in the wastelands all night and there was a cold draft blowing that night that seemed to freeze him to the bone and so he said, "It's the wind! It blows me's so meanly!" The Pixy was furious at this as she spoke and said, "I grant you that the answer to the second riddle is The Wind ... but now I shall give you a third puzzle that none have ever solved! Wanders round ... over ground ... talks to rocks ... where it walks ... when it's cold ... it turns to stone!"

Golly had been standing in the damp, moss covered wastelands for some time now and he then realized that his feet had become numb from the cold and moisture and all he could do was comment upon his miserable condition and so he said, "Golly! Me's feets a standin' in it! It's the water I say!"

The Pixy was totally infuriated as she sputtered, "Will wonders never cease! You guessed the answers to the first two riddles to be Butterflies and The Wind and now my unsolved riddle of Water too has the answer known! You must be a very powerful and wise being ... but I say, I will give you a fourth wish if you can but answer this riddle ... steel be rust ... man be dust ... this thing all things ... follows must!"

Golly stood there first balancing on one foot and then the other trying to get his feet to warm up and all he could think of was to stall as long as possible and so he said, "Time! Time! Me's got to have it!"

The Pixy looked at the Goblin in awe and she said, "Yes ... the answer is Time and I will now grant you the four wishes of your heart's desire!"

Golly looked at her fondly and exclaimed, "Golly! Me's always been looked at rather odd I say for me's appearance and more than anything else me's wants handsome looks."

Then Golly scratched his chin in contemplation and said, "Me's wants riches! Me's wants fame! So's me's can live in The Garden Of Delight with the gentle folks!"

So the Pixy said, "Those four wishes shall I grant thee that you shall be a handsome Prince. That you shall be wealthy. That you shall be renowned. That you shall reside in the graceful garden."

Then the Pixy placed a spell upon Golly and he was transformed into a handsome Prince and the Pixy led him to the Tiny Ones pots of gold and he became well known and bought a fine castle in the valley of The Garden Of Delight.

The Griffaera And The Wareacher

Eons In the past, upon the continent of Anotherealm, in the midst of the area named the Warplanes there grew a gnarled, large growth named the Knotree ...

Upon it were many strange and different plant-like kernels and one of these when it ripened fell to the ground to continue growing and produce a most unusual creature named ... the Griffaera.

The Griffaera was extraordinary in appearance in that it resembled a number of creatures conglomerated into one. It had a Lion's head, a Goat's body, Eagle's wings upon its back and the tail of a Serpent. It was capable of flight and when it matured it began soaring about the area of the Warplanes until it became familiar with its surroundings and the local inhabitants.

It then began soaring about the entire continent and saw the Wagglers and Wareachers of the Edgeery Wastes and their terrible prowess at producing horrid spells and potions that were dangerous to all but their own kind. This ignited the Griffaera's curiosity in such beings for it was within its nature to dominate all other creatures it encountered with its ferocious appearance and strength.

It was naturally over-aggressive and wished to confront one of the horrid beings to test its mettle against such a deadly force. Thus, the Griffaera soared high into the sky around the Edgeery Wastes until with its keen sight it saw the dilapidated, residence of the Wagglers and Wareachers named Watchalls. As it approached Watchalls from the gloomy, cloud riddled skies there appeared a solitary figure atop the tallest of the Watchalls castle towers. Once the Griffaera got close enough it could see that this was none other than one of the infamous Wareachers of Watchalls.

As it began to dive upon the horrid figure the Wareacher cried out in a fierce voice, "Ahaaa! Great monster of the skies! What is it that such an ignoble creature such as you desires from those of the crafts of sorcery?"

Hearing the anger in the Wareacher's voice incited the Griffaera and it let out a loud roar and flew around in circles about the Wareacher, taunting him and attempting to make the being become aggravated and perform some act of sorcery.

Then the Griffaera dove straight at the Wareacher and made an attempt to tear him to shreds with its razor sharp, poisonous claws and as it did the Wareacher dissolved into a misty ghost-like apparition.

The Griffaera soared back up into the sky again, perplexed at this action by the Wareacher and then the being returned to a solid state and yelled fiercely at the Beast, "See! I have the power to make myself seem to disappear right before your very eyes and you have no means of injuring me! You are inconsequential by comparison to my awesome, omnipotence and I shall show you that I have the ability to conquer such as the likes of you! Nothing is more powerful than a Wareacher for you are in my domain and I shall make you my prisoner and slave to do my bidding! I shall climb upon your back as your Master and ride about the continent and rule the Anothearth and skies!"

This taunting by the Wareacher truly angered the Griffaera and it dove at the Wareacher again in its efforts to slake the horrid being and as it did the Wareacher dissolved again and then two venomous fangs appeared from the mist as if to sink into the flanks of the great Beast and it howled in fright. The Griffaera was absolutely maddened by this assault and avoiding the fangs, soared back up into the clouds. Then it began fanning the clouds about in the sky believing that if it made the Sun of Anothearth shine brightly upon the Wareacher it would be able to see and attack it.

Little did the Griffaera know that a Wagglor or Wareacher was unable to stand the strength of broad daylight and as it cleared the clouds away the Wareacher shrieked and began to flee down into the castle's interior.

The Griffaera let out a mighty roar of triumph at vanquishing its foe and there were others of the horrid beings who witnessed the battle and were afraid of the Griffaera for they considered it to be an extremely powerful and intelligent creature.

A Short History Of The Elves

Once, many thousands of years in the past, there existed an ancient continent that was named Anotherealm. It was extremely large and engulfed a sizable area of the Anotheath so that it reached far unto the Northern hemisphere at its top where there were tundra bogs and at its bottom far to the South there was a blazing, hot desert of immense proportions. The regions in the midst of the land mass were more hospitable as far as living conditions go and stretching from the West unto the East was a range of tall peaks named The Mystic Mountains. There were lush forests on either side of the mountains in the central regions and in the midst of the mountains was a beautiful valley that contained The Garden Of Delight.

Within the garden grew the greatest of all trees ever to exist, the mighty Arborstar, the Tree Of The Fruit Of Eternal Life. Many amazing growths appeared upon the tree including those upon one limb that were called Gemelons. This limb of the tree was located at the very top and the fruits that grew on it were about the same size and shape as the average Cantaloupe, although of a very bright, translucent, pale Emerald color. Under the sunlight these growths appeared gelatinous and under the light of the stars and Moon they would refract in all the multiple colors of the rainbow. It was more than a century after the Gemelon fruits matured and fell to the ground and then they continued to grow and develop into the beings named Elves.

At first count there was a total of twelve Elves fully developed lying upon the grassy earth beneath the Arborstar in a deep trance. There were also many other Gemelons lying about the base of the Arborstar in various stages of development.

Then one night when the star Andromeles, The Starace was shining bright and its light traveled through the firmament it was eclipsed by the full Moon and a blinding shaft of light streamed down from the firmament into the garden and the combined twelve Elves awoke from their deep, transitional state of sleep.

At first they looked upon the world in awe for they were as yet naive beings. Yet, as days went by they met other beings who had originated from the Arborstar who intrigued and enlightened them and educated them in many ways.

Most beneficial to the Elves were the Dwarfs who also originated from the Arborstar of the limb that bore the succulent fruits, named Metaleaf and the Dwarfs were dwelling in the garden at that time. The Dwarfs had come into existence some centuries after those beings named Pixies, Sprites and Fairies of the Bulberry limbs, although they were centuries old themselves by the time the Elves had matured.

The Dwarfs learned to master many arts and crafts that they plied to the delight of all and especially Elfkind. In turn the Elves learned the arts and sciences with a refined touch of their own.

The Dwarfs were basically masons and metalworkers and from their forges they brought forth plow, ax, hammer and saw and other tools that the Elves in turn applied to fashion the beautiful woods of the forests into many wondrous articles.

The Elves also harvested the plants of the continent of Anotherealm and grew amazing crops. They were also highly adept at medicine and the making of healing potions that were highly prized by all other races.

As the Gemelon Elves traveled about on the continent of Anotherealm they came upon the great Noriver and equally mighty Whitheriver. They constructed beautiful ships with the bow shaped in the likeness of a Sea Horse to traverse the rivers and sail upon the seas.

When the first twelve Elves had awakened in the garden and subsequently met and learned speech from the Dwarfs they vowed among themselves to adhere to a democratic form of rule. As more and more Elves matured and awakened they were educated by the twelve elder Elves who trained them and taught them the right of fair representation.

Eventually, seven of the original elder Elves left the garden in search of adventure in the wilds of Anotherealm and numerous of the younger Elves followed them.

Three more of the elder Elves accompanied by a group of younger ones traveled North to the great forest that lies there with the Noriver in its midst. It was these and their followers who first built

the Sea Horse ships. They searched to the West of the Noriver until they found a suitable site for habitation and there they built the magnificent mansions of Hidever. The woodlands they occupied was named Elforest. They would sail North down Noriver and around the Western cape of Anotherealm, where by this time the Dwarfs had constructed a massive fortress named Mountowers. Here they would barter for exchange of goods and services with the Dwarfs.

The remaining two elder Elves went to the Southwest with their followers where they encountered a wooded area named Glowood Forest for the fact that the majority of its trees had sparkling, bright white bark. Eventually, the Elves of Hidever sailed around the continent and North up Whitheriver and encountered the Elves of Glowood Forest. The Elves of Hidever then taught them how to build Sea Horse ships similar to theirs. The Elves of Glowood Forest also sought to the West of the river and established their domain and habitation there, building mansions named Everhavens.

The Oracle Of The Fountain

There once was a pool that was the most mysterious of all bodies of water ever to have existed. In it was contained the essence of a pure and unique energy and thought and there were those who visited there who said that within the waters of this pool there existed a strange and benevolent entity. It is said in legend that a column of spray would form in the center of the pool and from it would emerge The Oracle Of The Fountain. It was translucent as a pure Sapphire and had the upper torso of a Man yet upon its head it had seven eyes and the horns of a Ram.

The oracle was a most curious form, for it could predict and foretell the future and it was sought by those who wished to know of the coming events. Usually it spoke in the form of a simile or riddle so that the answer it gave was sometimes obscure. Other times the visitor to the oracle was placed in a trance and developed the full knowledge of what was to be revealed by this entity.

The pool where the oracle resided was situated within a strange range of rock formations that were nameless and these were located North upon the continent of Anotherealm.

Passage to the oracle itself was most hazardous for the unwary traveler because the area where it was located was upon a major fault line in the geography and there were frequent earthquakes and tremors that loosened boulders from the ridges of the looming rock formations. In later times Wagglers, Wreachers, Gargoyles, Trolls and Goblins roamed about in the vicinity of the rock formations and were numerous, although they could not approach the oracle itself for it had a power of purity protecting it. Still, the horrid beings were able to attack any visitor who might approach the oracle by waiting in the pass that led to it.

There was one among those who saw fit to take it upon himself to seek the oracle for he desired its insight and although he had heard of the horrid creatures in that territory he had no fear of them for he was a mighty and powerful Wixaerd named ... Wolfgang.

The Wixaerd had been watching the developments of the continent of Anotherealm in his Crystal Hall for many years and was concerned over the masses of malevolent creatures that roamed in the area of the nameless rock formations that surrounded the oracle. There was only one pass through that area that led to the oracle that could be used with any safety in past times and now even that was overrun with the foul beings.

Wolfgang set out from his castle far to the South of the location of the oracle and traveled for many days towards it through the land until he reached the Edgeery Wastes that were predominantly populated by the horrid creatures. When he began approaching the rock formations near the pass wherein the oracle was it was dark and he was immediately confronted by a strikingly beautiful Woman carrying a basket of fruit. She offered the fruit to him and he immediately reached in the pocket of his robe and took a small handful of the dried powder of Watersweet and blew it in her face.

She instantly turned into an ugly old Wagglar and screeching, ran away from him. The Wixaerd continued into the pass that led to the oracle and as he did in the distance he could see a Goblin approaching him as fast as it could go, howling and cackling at him like he was its prey. Wolfgang reached quickly into his robe and withdrew his Whitherwand and uttered a powerful incantation, pointing to the cloud formation that was hanging overhead in the sky and from it a bolt of lightning erupted striking the Goblin with full force and totally incapacitating it.

The Wixaerd was apprehensive about what might attack him next as he continued down the pass and then as he passed a bend in it he came upon a pool of pure azure water that seemed to have an iridescent glow to it. From what he had learned of the oracle this had to be the site of it and the Wixaerd approached and spoke the Opening Spell he had been taught by his ancestors to summon The Oracle Of The Fountain. As he stood at the edge of the pool it began bubbling in the center and a fountain of spray rose from it high into the air.

Then, in its midst appeared the oracle and it spoke to Wolfgang and said, "There is a place farther along this pass in the mountains where you will find the very rare Lighthorn bush. Take the leaves of this plant and dry them and cast the powder of them upon the wind into the air currents and it will travel throughout the land and all atrocities shall be vanquished forever in this place!"

Then the oracle disappeared and the fountain ceased and receded back into the pool and the Wixaerd stood next to the placid pool contemplating what he had been told. Then he set out down the pass and had not traveled far before he was once again confronted. This time it was the infamous Man O'Saur. The Beast roared at him ferociously and charged and thinking quickly, he removed his pointed Wixaerd's hat and placed it on the creature's head as he stepped out of its way. Immediately the Man O'Saur became docile and fell to its knees and then laid down upon the ground in a deep slumber. Wolfgang carefully recovered his hat and hurried down the pass.

He had not gone far before he came to a bush whose leaves were crystal clear and tinkled against each other in the wind. This he realized must be the Lighthorn bush. He collected some of the leaves of the bush and put them on the ground to dry. He waited patiently for the Sun of Anothearth to rise and when it did the leaves dried very quickly. He gathered the dried leaves and crushed them and then as a strong gust arose he cast the powder into the wind.

It was not long before he heard horrid groaning and moaning about the area of the nameless hills where the rock formations were. He investigated the source of the sounds and found the signs of a great number of the horrid creatures that had been totally disenchanting by the Lighthorn powder. Wolfgang smiled contentedly in the bright sunlight of that heroic day for he had vanquished literally hordes of horrid beings with that simple act. Now others who wished to visit The Oracle Of The Fountain would find it accessible so that they could reap the benefit of its immense wisdom.

Mister Guessbox

In ancient times there lived a peculiar, little old Man in a forest named Crowood. It was named this for the fact that it was largely inhabited by Crows. The old Man would venture into the depth of the forest where the Blacknight trees grew and would gather those branches that had fallen from the trees.

Then he would return to his cottage that was nearby where he would take up his tools and arduously carve and construct small treasure chests out of the wood. He would engrave them, each one with a different and uniquely individual design.

What was most fascinating about these boxes is that within them could be found a treat each time they were opened. One merely had to take the gift and shut the lid on the small chest and wait until the following day and the little chest would provide another trinket as if by miracle. Most unusual of all, the presents found each day in such a treasure chest were never the same either.

On the edge of the forest some distance from the little old Man's cottage was a village named Dwellane. The Man would visit there on rare occasions where he would offer his boxes to residents for a fair price. No decent Dwellaner was without at least one of these special little boxes and some had several.

Each time the Man would approach the village the children would rush to greet him and exclaim, "Look! It's the Man with the boxes of guesses!"

Hence, the town's inhabitants called him Mister Guessbox. When he would enter the village the townspeople would hear the children's joyful greetings and they would come out of their houses to purchase his wonderful chests. Even those people who were working would stop what they were doing and commence to gather about Mister Guessbox in hopes of obtaining one of his amazing boxes.

The Man would chat nonchalantly with individual members of the growing crowd until he had determined what price to charge each single buyer. Some were of small or average income, some were wealthy and he charged each of them according to their assets.

One person in particular had not yet received his box even though he had approached Mister Guessbox numerous times. His name was Leston and he was among the very few who did not have an enchanted treasure chest. He was a sinister, devious person and it was common knowledge that the Man would not give those of questionable character one of his containers.

On one day in particular the old Man appeared in the village and began distributing the boxes unto those he thought worthy. Again, Leston approached him and requested a box in a demanding tone of voice. Mister Guessbox grimaced and shook his head at Leston in denial and once again ignored his request. Leston was displeased and then he asked the Man where he lived in Crowood forest.

To this Mister Guessbox looked him straight in the eyes and with a most serious tone of voice replied, "It is wiser for you not to ask such questions ... perhaps if you were to change your ways I might help you."

With that the Man slung his empty sack that he had brought the boxes in over his shoulder and turned and walked slowly down the lane towards the woods and his cottage.

Leston was infuriated, but kept a calm outward appearance for he had ulterior motives in mind and did not wish anyone to discover his plans. In Leston's mind were thoughts of fame and fortune. All he had to do was follow the old Man to his cottage, then wait for him to leave and then Leston could break into the building and steal all Mister Guessbox's treasure chests. These he could then take to some distant villages where they did not know of the Man and sell them for outlandish prices to the wealthier villagers.

Leston watched cautiously as the villagers dispersed and when he was sure no one was looking he began heading in the direction that Mister Guessbox had taken. Since the Man was traveling slowly it didn't take long before Leston who was walking quickly caught up and saw him ahead in the distance.

They were just about to the old Man's cottage and Leston remained unnoticed when Mister Guessbox reached his home and entered it. It had been late in the afternoon when they had departed

and Leston waited as nightfall arrived and he watched as the Man lit a lamp that he could see through the window in the building. Leston huddled next to a bush outside the cottage and kept alert all night long, so that he would be sure to see Mister Guessbox when he left the cottage and then he could get the treasure chests.

When morning arrived Leston finally saw the Man come out of his cottage with his sack and head off into the direction of the Crowood forest. After what seemed like an ample amount of time that Mister Guessbox had been gone Leston went up to the cottage and finding the door unlocked he entered the building and began haphazardly rummaging through everything in sight and yet he could not locate even one of the old Man's collection of treasure chests.

Leston was not about to give up that easily and he thought to himself that he would follow the trail of Mister Guessbox into the Crowood forest and there confront him to find out where he kept the priceless boxes. Now as far as he was concerned he did not care if the Man knew that's what he was after and even if he told others that Leston had stolen the chests by the time they came after him he would be long gone into some other area of the country with a sizable fortune. So, Leston headed off into the forest in the direction taken by Mister Guessbox in search of him.

As he hurried along he noticed that the farther he went into the woods the greater in size the trees were getting. At first he attributed this to natural causes but then the trees seemed to become gigantic as he traveled along and he slowed his pace somewhat in hesitation. Leston began wondering too about the Crows that he saw in the trees for they also were growing larger in dimensions the farther he got into the woods.

Also, the density of the leaves of the tops of the trees was shutting out the daylight and it was becoming darker the farther he went. He began becoming apprehensive about his surroundings for there seemed to be something unnatural about the forest.

Now Leston was actually becoming frightened by his environment and then suddenly, he saw the old Man looming above him in cyclopean proportions. With a deft sweep of his gargantuan hand Mister Guessbox scooped up the miniature Leston in his palm.

The old Man spoke and his voice was as deep as a canyon and reverberated in Leston's ears, "You are not the first to be inquisitive about my undertakings ... others too have followed me here and as you now see, the fear of the Blacknight trees and the Crows has caused you to shrink in size until you are but a minuscule being in comparison to me. The Crowood forest and its Blacknight trees have that and many other mystical powers. I will take you home with me and you will be placed in one of my treasure chests where you will continue to shrink until you are no longer able to be seen. Perhaps ... if you are a good little creature I might someday release you ... as for now I suggest that you center your thoughts about those things that are pleasant for I will watch your progress with scrutiny!"

With that Mister Guessbox lumbered off towards his cottage and when they arrived the old Man went to the far wall and touched a panel on it. Slowly, the wall slid aside to reveal an inner chamber filled with the treasure chests on shelves on the far wall. Leston was placed in one that was empty and the lid closed and he heard it latched from the outside so that he could not escape. It was so dark that he could not see anything and he was now terrified by the conditions of his entrapment.

Each day in the morning before Mister Guessbox left to collect Blacknight branches he would enter the chamber, open the lid of Leston's box and inspect him. When the light entered his abode it seemed extremely bright and Leston had to squint, but through his hazy vision he could see that it was true that he was continuing to decrease in size by comparison to the treasure chest.

Leston had not slept for many days because of his fear and finally out of total exhaustion he fell asleep. The next thing that Leston knew he found himself in a luscious, green meadow with many varied fruit trees and a sparkling, fresh brook filled with a multitude of all kinds of priceless gems. Flowers of every known genus and color grew in the grass of the meadow in great numbers and the Sun of Anothearth was shining brightly in the clear blue sky above him.

Leston felt completely at ease and skipped lightheartedly through the tall grass of the meadow picking flowers and then consuming his fill of the delicious fruit of the trees. Then he went over to the stream and picked a gigantic Sapphire from its cool, clear waters. Feeling satisfied and contented he

sat down with his back against a tree and wondered about this place for somehow he knew he was dreaming.

Then he began to doze off against the tree and as he drifted into slumber he wondered to himself, "How is it possible to dream within a dream?"

Mister Guessbox awoke that next morning and as usual went to check on Leston. There was no sign of him, but instead in the small box that he had put him in there was a beautiful, miniature bouquet of flowers and a small Sapphire.

A faint smile appeared on the old Man's face as he spoke quietly to himself, "Yes my little rogue! As I expected ... the power of Blacknight has overcome another of my adversaries and yet another Dweller shall soon be rewarded!"

Then, Mister Guessbox waited a few more days to see if there had been any further developments. When he opened the small box this time there was no sign of the flowers or jewel.

Mister Guessbox smiled again, a little more satisfied than last time and then closed the box and waited a few more days again. When he looked into the box this time he could see Leston in his small world, wandering along the edge of the stream and headed in the direction of the distant mountains and the forest that lie on the edge of them. Again, he closed the box and then he headed out of his cottage and towards the Blacknight Forest.

He strolled along slowly until he reached the edge of the forest where it met with the foothills. In the far distance he could see a figure approaching and he felt very pleased. When the other person saw Mister Guessbox he began running and calling out loudly, "Hello! Hello there! I am so glad to see someone." Then, as the person got close enough to see who it was he stopped immediately, as if apprehensive.

Mister Guessbox spoke to him, "Leston! Don't worry, I am here to help you my friend. I was expecting you to return and so I came looking for you. I want you to come to my cottage and help me with my work. It is a very great honor to be able to give to others and I believe you have that quality like unto no other I have met. Would you be interested in being my Apprentice?"

Leston, grinned widely and said, "Oh! Yes! Oh! Yes Mister Guessbox. I never thought I would ever see anyone again and I began thinking to myself of how my life could be different if I only had a chance. I would love to help you with your work."

Then, Mister Guessbox and Leston walked quietly back to the cottage and Leston was instructed in how to construct the wonderful boxes as Apprentice to his new Mentor.

He eventually built his own cottage some distance from Mister Guessbox and in time he became very adept at his new trade and almost as famous as Mister Guessbox for his wondrous ability to give unto others.

In fact, because no one recognized him since his encounter with Mister Guessbox they even gave Leston the name of ... Mister Change-case.

ANOTHEARTH RHYMES

Shine On Anotherealm

In past ... In ages long forgot, forever more now gone,
The continent of Anotherealm was, you hear of in this song.
A land of gold, so brave and bold, of Anothearth jewel so bright,
A wondrous place where dwelt of old, a race who loved all life.
Where Deer and Lion would abide, together in the field,
And never storm clouds filled the sky, eternal seas tranquil.
The mirth of all the children fair, their laughter's reverie,
Filled hearts of people everywhere, all now a memory ...
There grew the tree with Fruit Of Life, immortal in the Sun,
The Eagles on majestic high and Minstrels sang of love.
The Wixaerd, Sage and Poet delved, with spirit, eye and hand,
Wove spells that once embraced your realm with power and command.
And then you left this great Anothearth, before astonished sight,
No trace of all your treasured worth, was ever brought to light.
In midst of dark your fable told, unto the very small,
Their eyes grow wide as tale unfolds, of Mystic Mountains tall ...
Shine on Anotherealm, for you were built of miracles and dreams,
As you remind us, that you were the beauty, faith and peace.
For we'll never know the answer to our quest,
Where you lie beneath in final rest ...

Pixy Rhyme

Pickles and sticks, puckers and squints,
Splinters and Winters and lickety splits.
Goblins and rogues, boulders and stones,
Roamers and loners and groaners and moans.
Trouble and tub, rub-a-dub-dub,
Stubble and rubble and bubble and sud.
Sour and dour, flower and tower,
Power and glower and hour and cower.
Bowls and holes, Moles and coals,
Knolls and rolls and souls and tolls ...

Elfinwarriors

In days when Elfinwarriors fought,
And scorned dire fear with feats so brave,
In shining armor cunning wrought,
And crested helm with plume to wave.
Amidst the lands of heathen hordes,
And awesome monsters brimstone caves,
As mystic light did gleam on swords,
With hilts of jewel and fiery blades.
Behold! The Moon Of Gloom arise,
Bewitching Gargoyle, Goblin, Troll,
To dare the Elfinlords to fight,
For life, limb and immortal soul.
To halt these horrid beings of dark,
From songs of fear so sad to sigh,
That forge the brave stone fast and hard,
And cause their will to ever rise.
For endless days and nights untold,
The horrid forces raged to win,
And waged battle for the gold,
That lie in caverns filled to brim.
The Elves in battle cry did rise,
And forces foul did they then quell,
They wrote this song unto the wise,
Who tell this tale of all as well ...

Song Of Cyclops

Behemoth Cyclops, great of might,
Once roamed The Mystic Mountains grand,
Gargantuan of eye and hand,
Born long before the seed of Man,
Before the Wanestar came to sight.
Leviathan of living beings,
A shepherd noble, gardener kind,
Who tended flocks and branch and vine,
And kept The Garden Of Delight,
Wherein did prosper wondrous things.
His wisdom shared he with all kind,
Who came from far and wide to hear,
His tales of daring without fear,
Unto him drew the people near,
His voice was heard through hills and sky.
Alas, the Doomoon dimmed his view,
And thus, in time, he left his home,
Now dwells in Lostown all alone,
With ghostly winds that howl and moan,
Where once the mighty Earthorn grew ...

Fable Of The Mermaids

The Queen of Mermaids sits enthroned,
Enshrouded in the deep,
With Sapphire eyes and hair like gold,
That glitter, shine and gleam.
Her citadel that's wreathed in gems,
With towers of pure light,
Has never been beheld by Men,
Throughout all endless time.
Though mariners have said they've seen,
Some strange aquatic kind,
This fabled riddle told in rhyme,
The answer none can tell,
Of where the Mermaids dwell tonight,
Within their citadel ...

DraqueWixaerd

There is an Eagle, soaring up above him,
The Wixaerd waiting in the mist,
His flying sentry, searching for the one thing,
The Draque in the great Abyss.
And in the story, yes there is the legend,
The churning, burning Beast he rides,
With wings of leather and teeth of raw steel,
The monster's brimstone mouth afire.
The Serpent listens and the Wixaerd's voice now,
In ancient Draquespeech commands,
The Worm Of Fire turns amidst its red sky,
The mystic spell is cast again.
It is the might and mastery of wisdom,
That reigns supreme throughout the realm,
Forgotten ages somewhere in the pages,
Upon the Sage's dusty shelf.
He summons forces unknown to the real plane,
Within his mystic Crystal Hall,
And mixes potions; deft this Mystic Master,
The lightning bolts begin to fall.
His arm is raised now, lashing out with power,
Dimensions rip and tear apart,
He hurtles headlong, in the endless vortex,
His molten Steed drives fast and hard ...

The Smirk Of The Man In The Moon

Now, The Man In The Moon, He shone bright,
On one bold, cold and stormy old night,
In between mottled clouds,
That roundhouse rabble roused,
Oh! It gave Him the fright of His life!
So The Man In The Moon He came down,
To inquire why Nature did frown,
She said, "BEST YOU BE STILL!"
And to iron His will,
She then wound Him round bound the clown sound.
Well, The Man In The Moon, He broke free,
Heaven glory bound sprang He with glee,
She clung fast to His head,
So He left it and fled,
And She harnessed it lock, stock and key.
So, The Man In The Moon, He did feign,
Tossed His reins in the ruckus and fray,
And now since that odd night,
He does smile quite awry,
For He's lunatic unto this day!

Why The Man In The Moon Ran Too Soon

In a land filled with rime and hoarfrost,
Of a mythical time that is lost,
Lived The Queen Of Deice,
In her castle of ice,
She had gems that were fine of great cost.
On her nape was a pearl filigree,
In its visage the world she could see,
With a wave of her hand,
All four winds at command,
Would be swept up and whirl to be free.
So she loosed the four winds on the earth,
Just to meddle with Man's own true worth,
Then a Northeastern blow,
That she sent with its snow,
Made her laugh at her sins in vain mirth.
The snow blanket she spread for a bed,
In her wake and the dread of her tread,
Covered mountains and trees,
And the cold froze the seas,
And whatever she wed held no stead.
Then The Glade Of Delight she did spy,
Nestled warm in sunlight from the sky,
To the Sun she then said,
"You look tired, take your bed."
And she sang a goodnight lullaby.
Well the Sun slept so sound he went down,
In sweet dreams was he bound to be found,
Then The Lady Of Ice,
Knew her gaze would suffice,
To cause icicles round on the ground.

Why The Man In The Moon Ran Too Soon (Cont.)

Now The King Of The Glade felt the blade,
Of an icicle laid in the shade,
By this Maiden Of Vice,
And her cold-hearted eyes,
Then he saw through the jade of her trade.
He decided to make the winds brake,
So the Sun he did shake and awake,
And the storm he did seize,
With a Spring Zephyr breeze,
Just to make her forsake her mistake.
With a flurry the gale turned Mare's Tail,
Merry-Go-Round to hail its own trail,
And The Dame Of All Lies,
Was fast bound in the ice,
Of her own frosted veil of cold mail.
And the mystical pearl filigree,
The Glen Lord did then hurl in the sea,
When it spilled in the reach,
The waves bore it to beach,
Where it climbed to unfurl in a tree.
To the stars it did race all the way,
The pearl charm sought a place it could stay,
And it caught the profile,
As The Glade King did smile,
Now it still bears his face to this day.
Some folk say that it ran up too soon,
For its pace never can keep a tune,
It eclipses the Sun,
With its lunatic run,
And they call it The Man In The Moon ...

Saga Of Silverlark

Sail the ocean filled with motion,
Far from lands that we once knew,
Across the rolling sea of blue,
For to find the Master's potion.
Breathless heights of sheer cliffs white,
Meet the crashing ocean's thunder,
From beyond bolt lightning sunders,
In the glare ... Enchanted Isle.
From the sound, up through the down,
To the mount above the sea,
Between high pass and Wixaerd's tree,
To the door in leaf clad gown.
Cavern dark and cryptic mark,
Scribed on torch lit wall that gleams,
Cyphered Symbol voyagers seek,
Secret of wise Silverlark.
Betwixt two stones are where his throne,
Stands unseen to mortal view,
Look through gem of Cat's Eye blue,
You will see his Whitherbone.
Grasp it tight and feel it bite,
Shaking, quaking, points the way,
To the crack where light of day,
Shines upon the path that's right.
Tread so stealthy, up the stair,
Through the passage in the maze,
And the gloomy, murky haze,
Chilling bone of all who dare,

Saga Of Silverlark (Cont.)

Pass before the Man O'Saur,
Creature loathe with eyes of red,
Claws of poison, fiery breath,
Mighty roar of smoke and power.
Speak his name, soft twice again,
Horbeast slumbers to the call,
Muffled footsteps down that hall,
To the horde not touched by Man.
Silverlark your Master's harp,
Stands untouched through time on end,
Songs once carried on the wind,
Melodies so clear and sharp.
Scepter grand, once filled your hand,
Now lies power spent in dust,
Dimming jewels, musk, tarnish, rust,
Tell the tale of your fair land.
By the Elfinmaid of yore,
And that which is now in store,
Life eternal ever more,
To the conqueror of this quest ...

The Tallest Of Trees

The tallest of trees, a mammoth to see,
The Arborstar reigns over all.
With gigantic girth on great old Anotheath,
And everything else looks so small.
Throughout endless Time its branches sublime,
Reach into the Heavens above.
The strength of it grows and everyone knows,
It's mightiest under the Sun.
When stars were first born this tree did adorn,
The planet with beings galore.
The Deer in the fields and Knights who did yield,
Such armor and glittering swords.
Although Time may pass and some things not last,
The memory always remains.
The huge Tree Of Life is there in broad sight,
So massive with such awesome name.

The Greatest Of All Continents

Another realm was once the greatest continent in all of Time.

It stretched from North to South and East to West.

For Man did live there with the Beast and all was in its prime.

The Elves were noble, as was all the rest.

The Dwarfs were mighty although small and roamed about Anothearth.

The Man O'Saur; ferocious and so wild.

For those of true heart could be seen for all that they were worth.

The Queens were very beautiful and mild.

The Aborigine traveled over desert and the dunes.

They practiced healing arts unto the wise.

Magnificent were Mystic Mountains and the ancient tunes.

With Fairies filling one with such surprise.

The stars that twinkled in the sky were sacred unto all.

And Moonlit nights were beautiful to view.

With fiery breath the Draqunes then did voice their mighty call.

And Wixaerds cast their spells enchanting too.

Captain Sea Eyes

Cloudless sky, blue at sunrise,
Roses bloom in hues of Summer.
Like the love of all my wonders,
Sapphire light glows in your eyes.
Morning Star, is in my charts,
Sun is shining like my sweet dreams.
Galaxies of bright moonlight beams,
Shower down from on afar.
Fragrant sounds, refrains all 'round,
Fearless souls are what we shall be.
Treasures sweet in retreat,
Crescent waves to shore are bound.
Surf is clear, and you are near,
We are sailing on a journey.
Bound for shore and what's more,
We will find the endless dream.
Sail aloft with all your sight,
Captain Sea Eyes guide us through the night.
Sound your song of fathoms right,
Captain Sea Eyes ride the tide so light ...

The Wixaerd And The Draque

An awesome sight this Draque is so regal winged in stature,
Aloft, alight the silver clouds it speeds along in rapture.
Its mighty eyes magnificent aflame with phosphor fire,
And rainbow scales upon its withers sparkling in attire.
It soars the sky melodious its flashing wings in ascent,
Its roar is like the trumpet strong to herald the Sun's advent.
Arise! Oh wondrous steed of fire and soar into the Cosmos,
Your Master is awaiting and he cherishes you the utmost.
The prancing, dancing true song of a charger's hooves gone headlong,
Into the ethers of the Unknown where its Master's call is so strong.
And standing near awaiting poised to meet this Draque there soon,
The Wixaerd's wand does hold the stars and shining bright the full moon.
Now in his grasp he holds the staff of righteousness and power,
Awaiting the first moment when the Sages mark the hour.
With faith among the chosen In the realm filled with their blessing,
To triumph and enfold all who are pure of heart in questing.

The Wixaerd's Quest

A rampart strong, a fortress great,
And midst the trees, a glowing gate.
That none may see for cast of spell,
Save Wixaerds wise the Elves do tell.
The Gryphons soar above, ahead,
Great sentries in the Sage's stead.
As to the council Lords do go,
To hear the wise who reap what's sown.
With words of charm so true and right,
That capture hearts with strength and might.
And round the oval table drawn,
They speak of peace until the dawn.
To plot the course the Seer must take,
Out to the sea, unto the wake.
He seeks the isle of his birthplace,
This Icon, Master of his race ...

Azureone

As he wanders down the lane
Smiling bright renowned of fame
Robed in clothing that is fine
People say that he has truth and glory
Traveling on in fabled times
Hair of gold and silken shine
Speaking with the Elder Ones
Helping people with his healing stories
Now he dwells at home sound of body mind and soul
In the land of the great and the bold
And the people say that he oftimes shows the way
As a Wise Man has the very power they say
Pussywillow buds of Spring
Sitting in a meadow green
Sunny days spent in the glade
Waiting for the Summer rains and Autumn
Stars at night and Northern Winds
As he passes by an Inn
From within there is a din
Lets his cares go with the snow and Winter
As he travels far guided by the Evenstar
All the memories give him peace within his heart
Everhavens white are now near within his sight
For he travels by them very oftentimes
In the symbols shown are the secrets that are old
And they keep the children safe and warm at night
In their dreams of sleep silent thoughts that they do glean
Of a land that is a wonder in their sight
Azureone and his tales are dear to hold
And he often gives his wisdom when he speaks
Strings that he plays a melody so strong
With gladness of each song that he does sing.

Mountowers Song

Mountowers looms upon horizon
Massive girth, immense of size.
In the distance of the dunes
Standing bold beneath bright Moon.
From its summit one can sight
Coast of land and sea at night.
To the North the Mystic Mountains
To the South Enchanted Isle.
Wells of lava; molten fountains
In its caverns long in miles.
There are forged the countless tools
Unexcelled in worth of jewels.
Strongest of all metals known
Of Anothearth and Anotherealm home.

**"Tales of Anothearth"
To Be Continued ...**

Songs Music

with Guitar Chord Diagrams

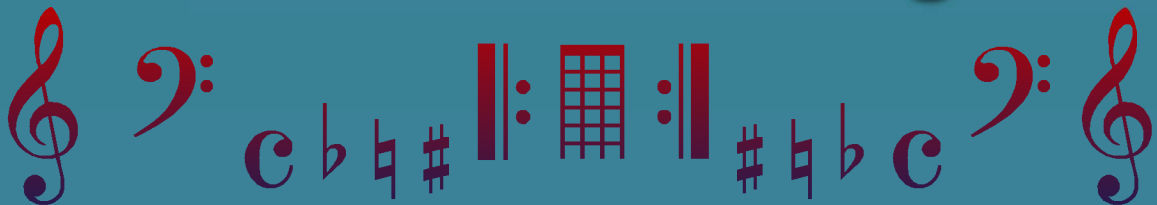

by
Paul William Engholm

Songs Music

with Guitar Chord Diagrams

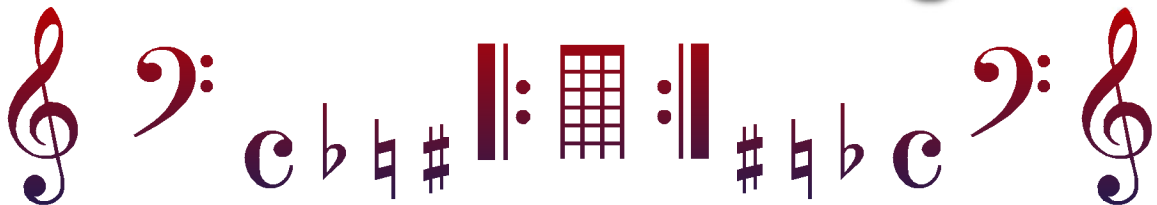

by
Paul William Engholm

Table of Contents

Song Scores:

AzureOne
Captain Sea Eyes
DoveKnight
DreamFlyer
DreamSeeker
Give Away
Granite Garnet
Inlet Sun
Magic Theme
My 1st Song
Passing Fancy
Savor Favor
Toys 2 Love
TruthFinder

Instrumental Scores:

CelebraTune
FalconFlight
HauntinGale
Horizoneer
LoveSight
Majestic March
Mirage Mirror
Orientalizer
Pause For Five
PranceAlong
RagTime Roller
RuneTuner
Star Emerald
StrollAway
TwiliTime
White Crow Waltz

Guitar Chord Diagrams

... Supplemental ...

Song Scores

AzureOne

Composer: Paul William Engholm

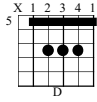
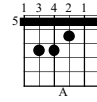
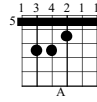
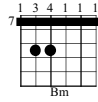
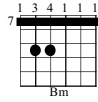
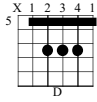

$\text{♩} = 160$

As _ he wan - ders down the lane _____ Smil - ing
Pus - sy - will - ow buds of Spring _____ Sit - ting

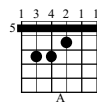
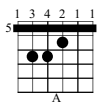
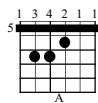
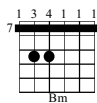
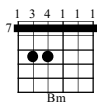

bright re - nowned of fame _____ Robed in
in a mead - ow green _____ Sun - ny

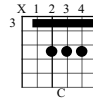
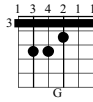
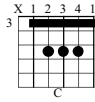
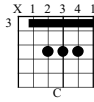
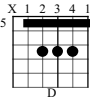

cloth - ing that is fine _____ Peo - ple say that he has
days spent in the glade _____ Wait - ing for the Sum - mer

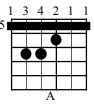
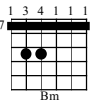
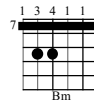
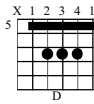
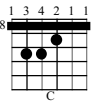
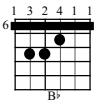

truth and glor - y Trav - el - ing on in fabl - ed times _____
rains and Au - tumn Stars _ at night and North - ern Winds _____

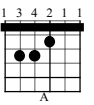
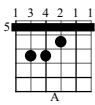
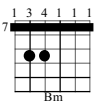
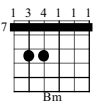
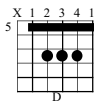
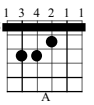

Hair of gold and silk - en shin _____
As ___ he pass - es by an Inn _____

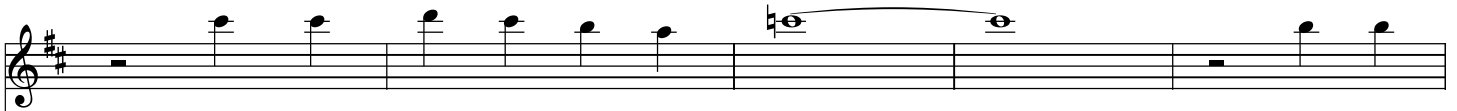
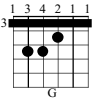
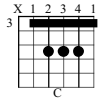
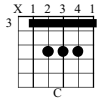
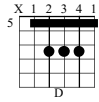
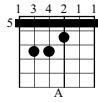

Speak - ing with the Eld - er Ones _____ Help - ing
 From with - in there is a din _____ Lets his

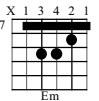
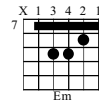
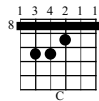
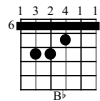
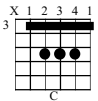
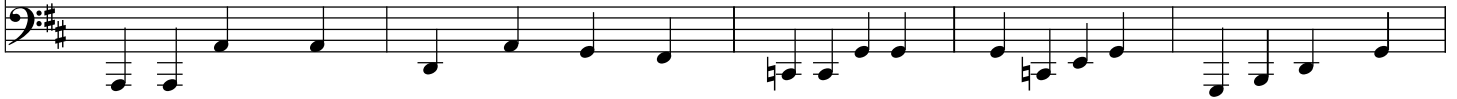

peo - ple with his heal - ing stor - ies Now he dwells at home _____ sound of
 cares go with the snow and Win - ter As he trav - els far _____ guid - ed
 sym - bols shown _____ are the

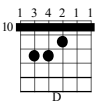
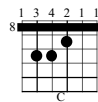
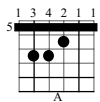
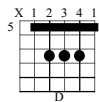
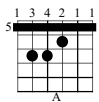

bod - y mind and soul In the land _____ of the great _____ and the
 by the Ev - en - star All the memo - ries give him peace with - in his
 se - crets that are old And they keep the child - ren safe and warm at



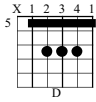
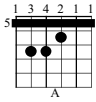
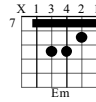
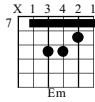
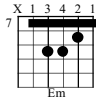
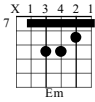

bold _____ And the peo - ple say _____ that he of - times shows the
 heart _____ Ev - er - hav - ens white _____ are now near with - in his
 night _____ In their dreams of sleep _____ si - lent thoughts that they do

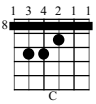
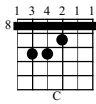
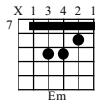
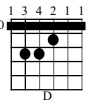
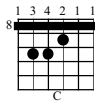
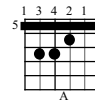

way As a Wise Man has the ver y power they say _____
 sight For he trav - els by them ver - y oft - en
 glean Of a land that is a wond er in their

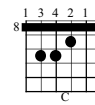
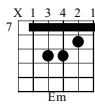
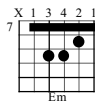
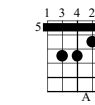

times _____ In the sight _____

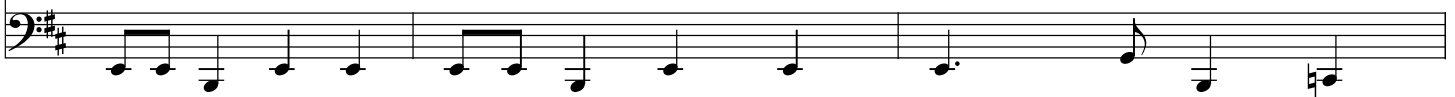
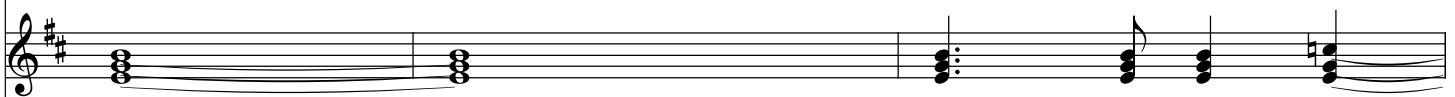

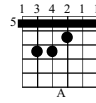
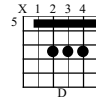
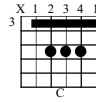
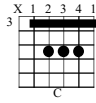
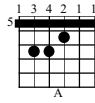
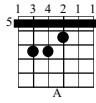

A - zure - one _____ and his tales are dear to hold And he
 Strings that he plays _____ a mel - o - dy so strong ____ with

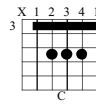
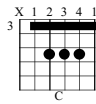
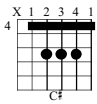
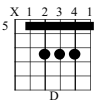
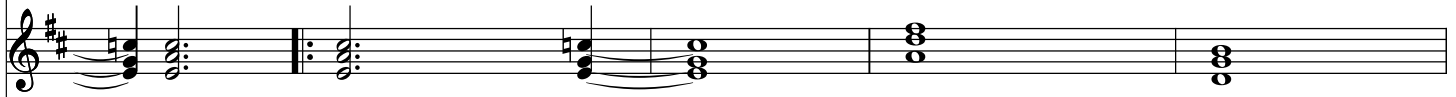

oft - en gives his wis - dom when he speaks _____
 glad - ness of each song that he does sing _____

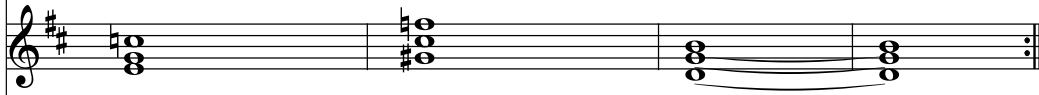

Captain Sea Eyes

Composer: Paul William Engholm

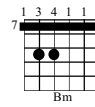
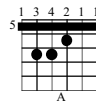
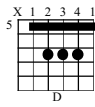

♩ = 120

Cloud - less sky blue at sun - rise _____ Ro - ses bloom __ in
 Mor - ning Star is in my charts _____ Sun is shin - ing
 Fra - grant sounds re - frains all 'round _____ Fear - less souls __ are
 Surf is clear and you are near _____ We are sail - ing

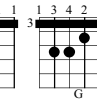
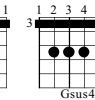
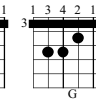
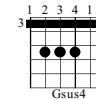
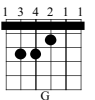
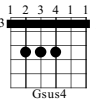
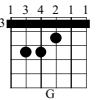
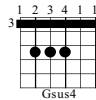
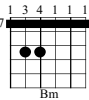

hues of Sum - mer Like the love of all my won - ders
 like my sweet dreams Gal - ax - ies of bright moon - light beams
 what we shall be Trea - sures sweet __ in re - treat __
 on a jour - ney Bound for shore __ and what's more __

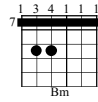
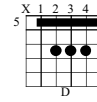
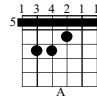
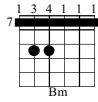

Sap - phire light _____ glows in your eyes Sail a - loft with all your
 Show - er down _____ from on a - far Sound your song of fath oms
 Cres - cent waves _____ to shore bound
 We will find _____ the end less dream

x4

x4

x4

x4

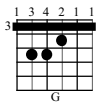
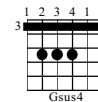
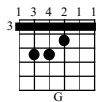
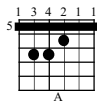
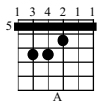

sight _____ Cap - tain Sea Eyes
 right _____ Cap - tain Sea Eyes

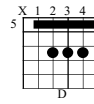
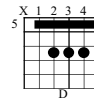
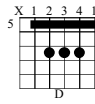
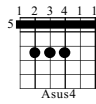

1. 2.

guide us through the so night light

ride the tide the so night light

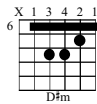
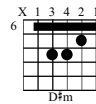
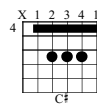
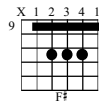
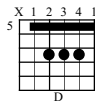

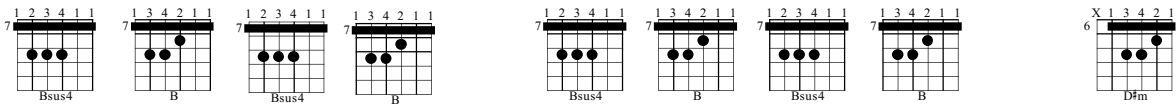

Musical notation for the first system, including treble and bass staves with chords and melodic lines.

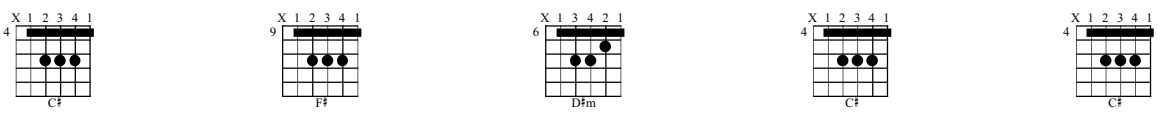

Musical notation for the second system, including treble and bass staves with chords and melodic lines, featuring repeat signs with "x4".

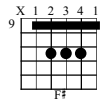
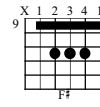
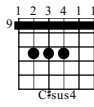
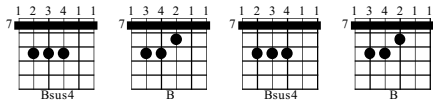

1.



2.

DoveKnight

Composer: Paul William Engholm

$\text{♩} = 100$

0 2 0 1 0 Am7 0 2 0 1 0 E7 X X 0 2 3 1 Dm

Where ev - er you wan - der I will be

0 2 0 1 0 E7 0 2 0 1 0 Am7 0 2 0 1 0 E7 X X 0 1 0 2 Ddim7

near Wnen ev - er you pon - der Know that I

X 3 2 1 1 X E+5 0 2 0 1 0 Am7 0 2 0 1 0 E7 3 2 0 0 4 G

care To guide and pro - tect you To show you the

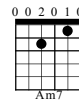
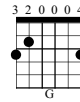
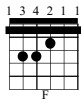

way A Knight who will love you My Dove be

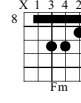
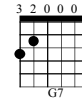
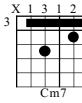
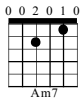

brave

x6

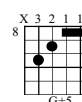
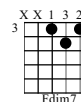
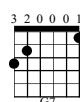
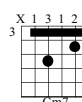
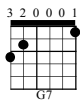

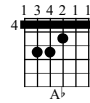
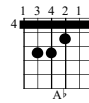
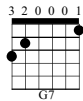
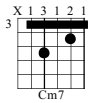

First system of musical notation, including treble, guitar, and bass staves.

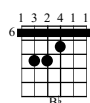
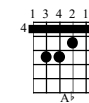
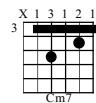
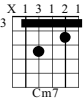
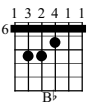

Second system of musical notation, including treble, guitar, and bass staves.

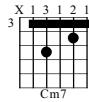
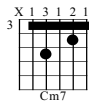

Third system of musical notation, including treble, guitar, and bass staves.

DreamFlyer

Composer: Paul William Engholm

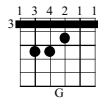
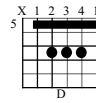
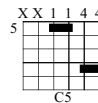
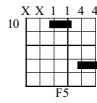
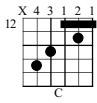

♩ = 120

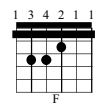
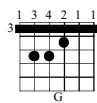
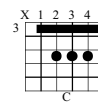
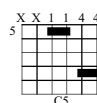
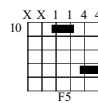
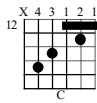



Have you e - ver _____ flown in dream to
 E - ven if _____ it's just a dream a -
 Now that you _____ have found the way it's
 Peace on Earth _____ with Lib - er - ty E -



soar a - bove the Earth _____ Al - though you know _____ you
 - noth - er point of view _____ When you a - wake _____ your
 like a dream come true _____ For one who has _____ so
 - qual - it - y for all _____ Be faithful to _____ the

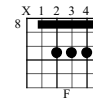
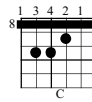
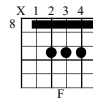
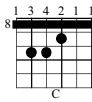
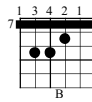
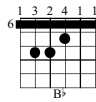
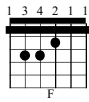

have no wings you fly for all it's worth _____
 life is changed you feel just like brand new _____
 much to say the light comes shin - ing through _____
 ones you love stand proud and strong and tall _____

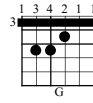
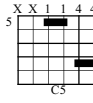
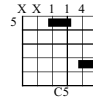
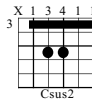
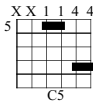
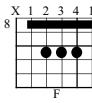

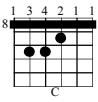
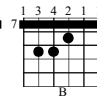
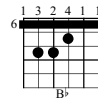
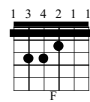
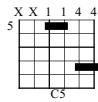
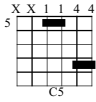

Musical notation for the first system, including treble and bass staves with chords and a melodic line.

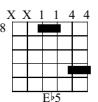
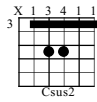
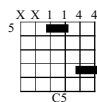
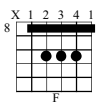
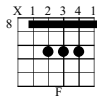
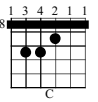
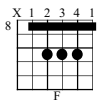

Musical notation for the second system, including treble and bass staves with chords and a melodic line.

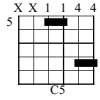
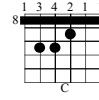
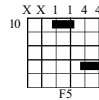
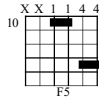
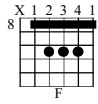
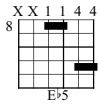

Musical notation for the first system, including guitar chord diagrams and a four-staff arrangement (treble, guitar, melody, bass).

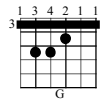
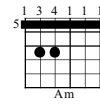
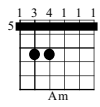
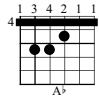
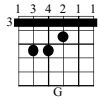
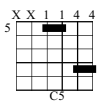

Musical notation for the second system, including guitar chord diagrams and a four-staff arrangement with lyrics: "You look up - on the world and now you are So fly with - in your dreams for you are".

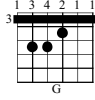
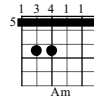
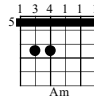
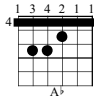
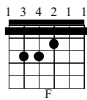

see free How won - der - ful all life can real - ly
 The wings you havbe are dreans e - ter - nal -

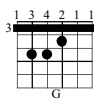
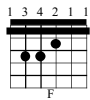

Da ⊕

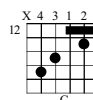
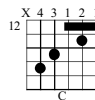

be _____ You seek to find the wis - dom that is
 - ky

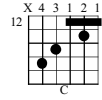
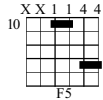
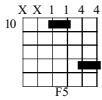

in the world _____ To share the peace of

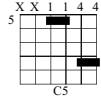
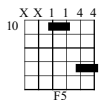
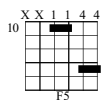
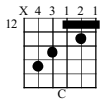

mind that you have found _____ Each mo - ment is a - noth - er

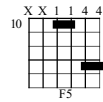
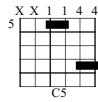
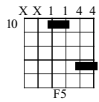

joy you find A hap - pi - ness you have to share

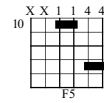
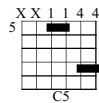

Your life is awe - some and your thoughts are kind

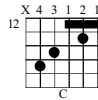
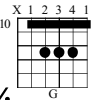
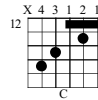
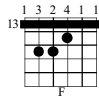

Dal Segno $\text{\textcircled{S}}$ *Al Coda* $\text{\textcircled{C}}$ $\text{\textcircled{C}}$

Be - cause it's true you real - ly care

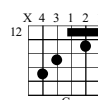
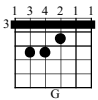
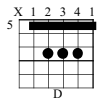
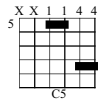
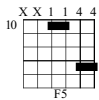

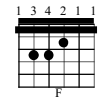
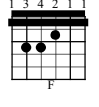
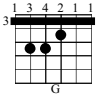
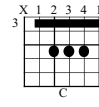
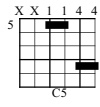
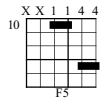

A musical score for guitar, consisting of four staves. The first two staves are empty, representing the guitar's harmonic series. The third staff is in treble clef and contains a melodic line with eighth and sixteenth notes, starting on the 10th fret and moving down to the 5th fret. The fourth staff is in bass clef and contains a bass line with quarter notes, starting on the 10th fret and moving down to the 5th fret. The score concludes with a double bar line.

DreamSeeker

Composer: Paul William Engholm

♩ = 120

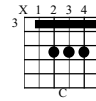
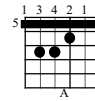
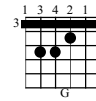
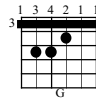
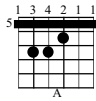
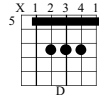
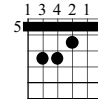
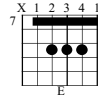
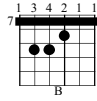

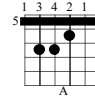
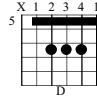
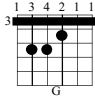

I day - dreamed on one clear blue night a -
 Sooth - sayer next I sought to seek to
 as I turned to walk a - way he

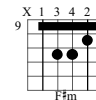
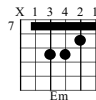
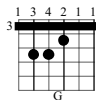

- bout the East - ern Sun It sank in - to the
 tell me what I gleaned As if time trav - eled
 said "it's no il - lusion For day - dreams bring us

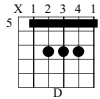
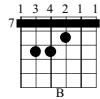

shimmer - ing waves and drank them one by one Then
 back - wards then in this e - lu - sive scene He
 to the truth and that is my con - clusion"

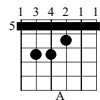
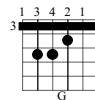
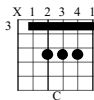
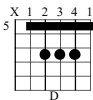

clouds of great white bill - owed out and rose int - to the stars The
 said "The past is mem - o - ries so bright just like the Sun Im



sun - beams danc - ing all a - bout and rain - bows e - choed far
 mersed in time just like the sea of rev - er - ies be - gun

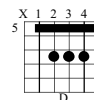
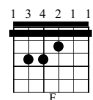
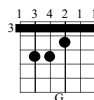
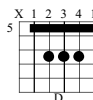
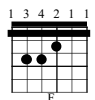
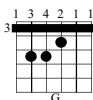

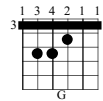
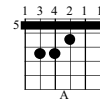
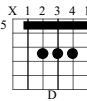
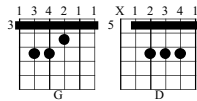
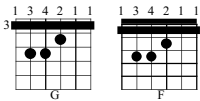

Musical notation for the first system, including treble and bass staves with chord diagrams and a section labeled "A Then".

A
Then

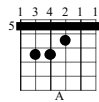
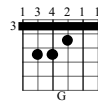
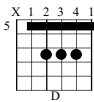
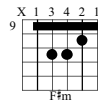
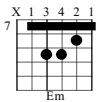

Musical notation for the second system, including treble and bass staves with chord diagrams.

Give Away

Composer: Paul William Engholm

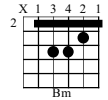
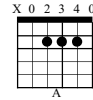
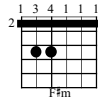

♩ = 120

The no - mads in pass - age were gath - ered in
voice was like thun - der they gath - ered a -
drew from his cape wrap the tab - lets of
crowd that was gath - ered then list - ened to

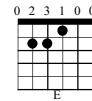
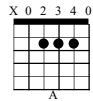
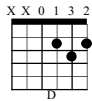
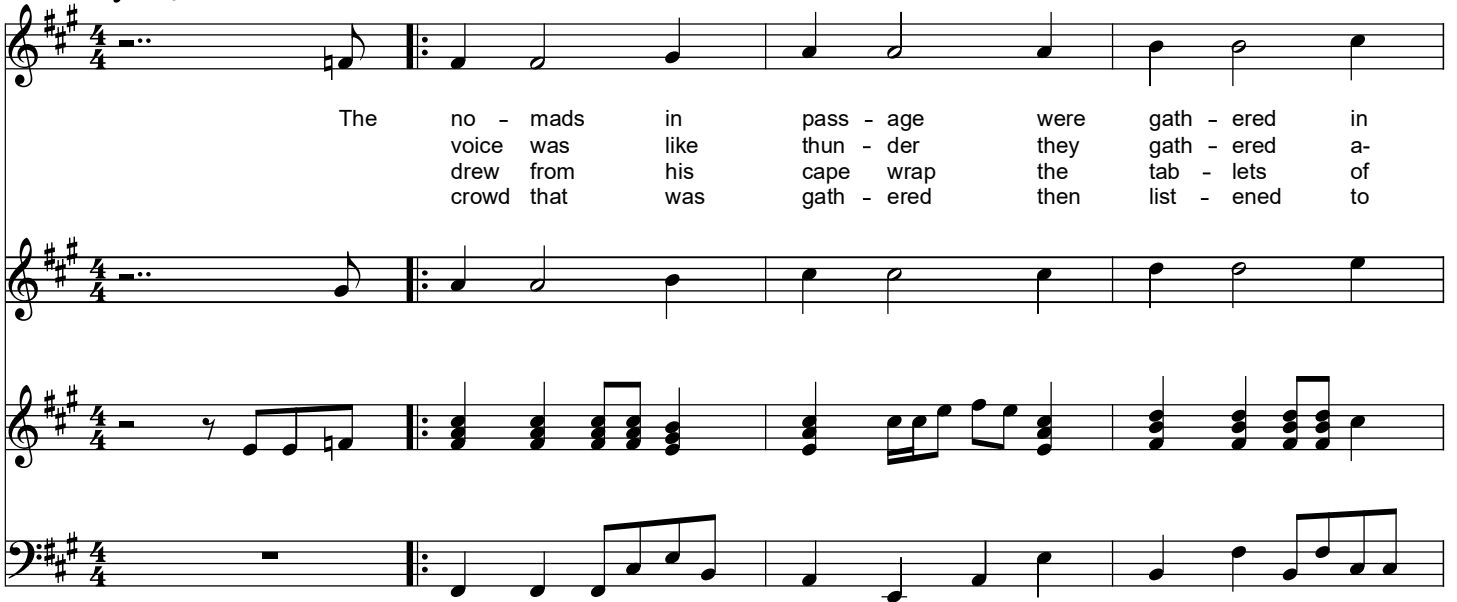

wait - ing the lead of the so - journ came
round him he spoke of a vis - ion a
bless - ing the writ - ings in white light on
hear him as A - zure - one shared the pre -

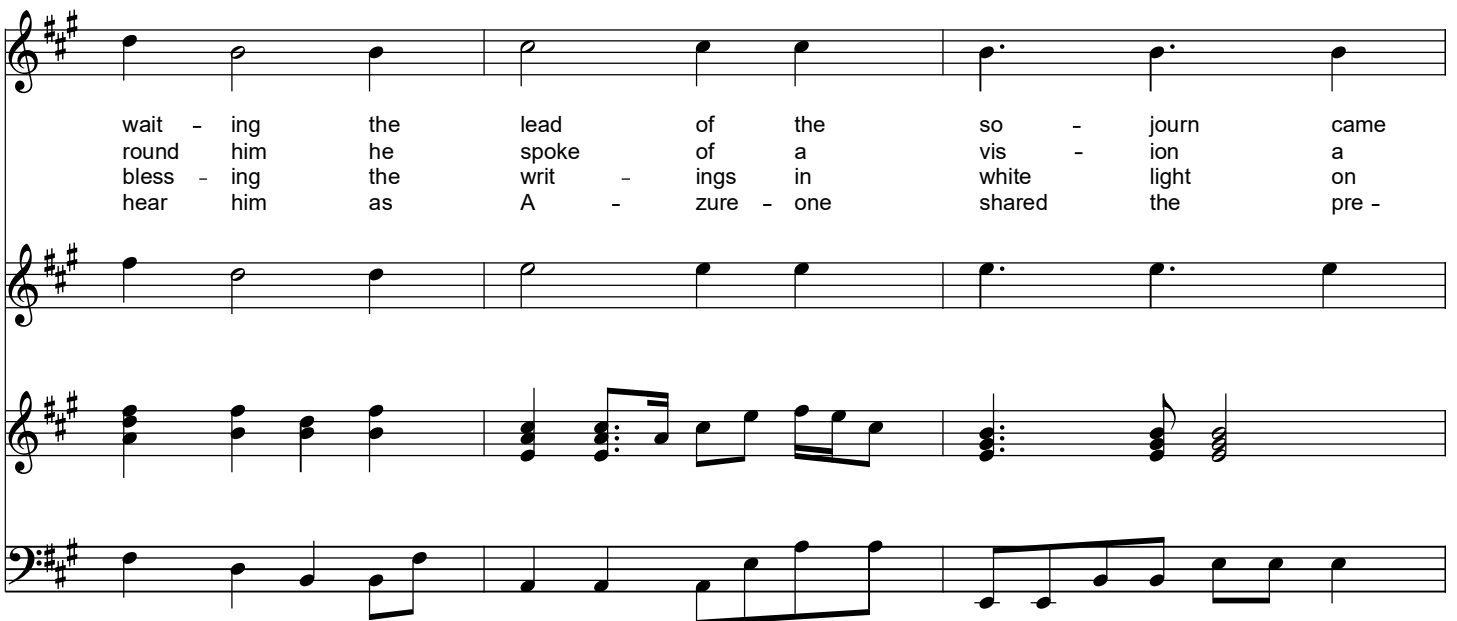

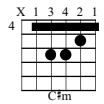
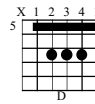
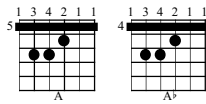
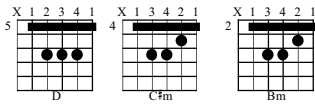

x4

down from on high His truth is in the know ing
 won - der - ful sign He
 stones of pure gold The
 - dict - ions of old "The

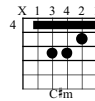
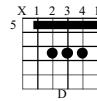
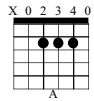
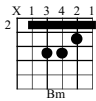

x4

good - ness has no end The mess - age there is grow - ing

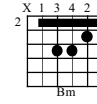
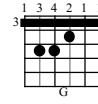
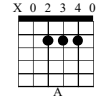
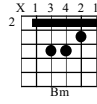
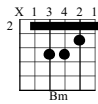

It's man - na for thought my friends It's man-na _ for

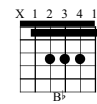
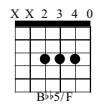
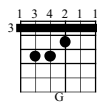
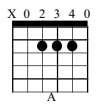
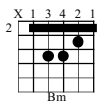

Da \oplus

thought my friends" Bas - ket was seen float - ing on
Brought there by fate and with his

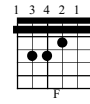
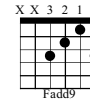
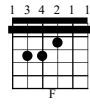
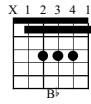
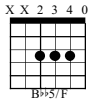

down End - les - stream in it a child who a - ston - ished them
 leg - end so great for - ev - er e - choed through time's end - less

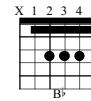
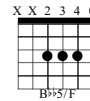
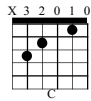

all halls One and all shared in all the

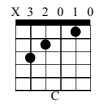
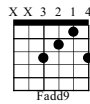
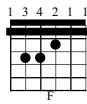
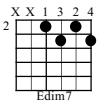
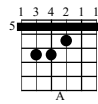
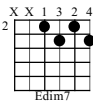

wealth that he fared and then they pros - pered for e - ver more So

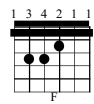
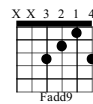
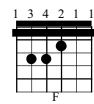
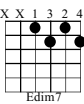
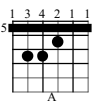
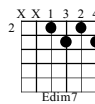
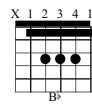
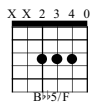

No - ble and kind and he was learn - ed and wise he al - ways guid - ed the world as he

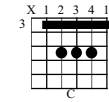
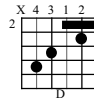
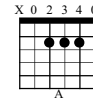
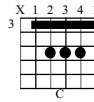
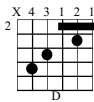
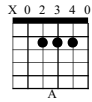
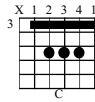
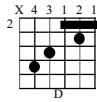
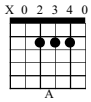

spoke

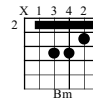
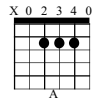
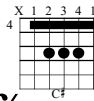
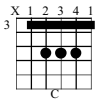
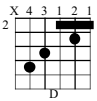
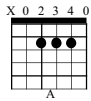

Dal Segno S *Al Coda* C C

Hear him speak: "The Give A - way to share the treas - ure

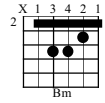
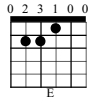
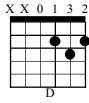

Give A - way brings light Give A - way in such good mea - sure

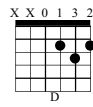
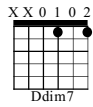
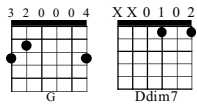

Give A - way is sight

Granite Garnet

Composer: Paul William Engholm



♩ = 120

The first system of musical notation consists of five staves. The top staff is a grand staff (treble and bass clefs) with a key signature of three sharps (F#, C#, G#) and a 4/4 time signature. It contains a whole rest in the first measure and a whole note in the second measure. The second staff is a single treble clef staff with a key signature of three sharps and a 4/4 time signature. It contains a whole rest in the first measure, followed by a melodic line starting in the second measure. The third and fourth staves are grand staves with a key signature of three sharps and a 4/4 time signature, each containing a whole rest in the first measure and a whole note in the second measure. The fifth staff is a single bass clef staff with a key signature of three sharps and a 4/4 time signature, containing a whole rest in the first measure and a whole note in the second measure.

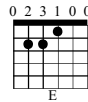
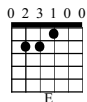

The second system of musical notation consists of five staves. The top staff is a grand staff with a key signature of three sharps and a 4/4 time signature, containing a whole rest in the first measure and a whole note in the second measure. The second staff is a single treble clef staff with a key signature of three sharps and a 4/4 time signature, containing a whole rest in the first measure and a melodic line starting in the second measure. The third and fourth staves are grand staves with a key signature of three sharps and a 4/4 time signature, each containing a whole rest in the first measure and a whole note in the second measure. The fifth staff is a single bass clef staff with a key signature of three sharps and a 4/4 time signature, containing a whole rest in the first measure and a whole note in the second measure.

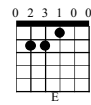
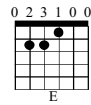
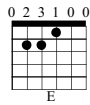

if you

The first system of music features a vocal line in treble clef with a key signature of three sharps (F#, C#, G#) and a 4/4 time signature. The lyrics "if you" are positioned below the vocal line. The guitar accompaniment consists of five staves: four treble clef staves and one bass clef staff. The guitar parts include a lead line with eighth-note patterns and a bass line with a steady eighth-note accompaniment. Three guitar chord diagrams for E major (0 2 3 1 0 0) are placed above the first three measures of the guitar part.

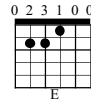
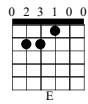

want to be a win · ner

The second system of music continues the vocal line with the lyrics "want to be a win · ner". The guitar accompaniment follows the same structure as the first system, with five staves (four treble clef and one bass clef). The lead guitar part features eighth-note patterns, and the bass line provides a consistent accompaniment. Three guitar chord diagrams for E major (0 2 3 1 0 0) are placed above the first three measures of the guitar part.

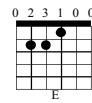
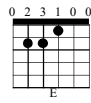
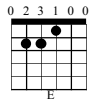

if you want to be a win - ner
If you - want to be a win - ner



1. If you
2. If you

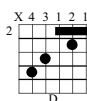
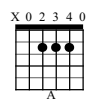
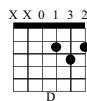
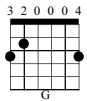
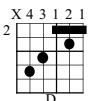
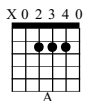

Musical staff with notes and rests.

want to be a win - ner
want to be a win - ner

You just gpt _____ to be - gin
You just gpt _____ to be - gin

Musical staff with notes and rests.

Musical staff with notes and rests.

Musical staff with notes and rests.

Musical staff with notes and rests.



Musical staff with notes and rests.

If you wat to be a win - ner
f you wat to be a win - ner

Well it ain't _
Well it ain't _

Musical staff with notes and rests.

Musical staff with notes and rests.

Musical staff with notes and rests.

Musical staff with notes and rests.

X 0 2 3 4 0
A

X 4 3 1 2 1
D

3 2 0 0 0 4
G

X 3 2 0 1 0
C

X 0 2 3 4 0
A

X 4 3 1 2 1
D

no sin If you want to be a win - ner
no sin f you want to be a win - ner

3 2 0 0 0 4
G

X X 0 1 3 2
D

X 0 2 3 4 0
A

X 4 3 1 2 1
D

3 2 0 0 0 4
G

X 3 2 0 1 0
C

You got to rock and roll If you
You got to rock and roll



Learn to rock and roll it ain't that tough Take a shot of cour - age
 Learn to rock and roll it ain't that tough Take a shot of cour - age



1.
 strut your stuff stuff Ain't no need to wor - ry
 strut your stuff



Take it off the cuff if you



The first system of music features a vocal line with the lyrics "Take it off the cuff if you". The guitar part consists of a melodic line in the upper register and a rhythmic accompaniment of chords in the lower register. The bass line provides a simple harmonic foundation.



Ain't no need to worry

The second system of music features a vocal line with the lyrics "Ain't no need to worry". The guitar part continues with a melodic line and chordal accompaniment. The bass line remains consistent with the first system.



Dal Segno  *Al Coda*  

Take it off the cuff

The first system of the musical score consists of five staves. The top staff is a vocal line in treble clef with a key signature of three sharps (F#, C#, G#) and a common time signature. It contains the lyrics "Take it off the cuff". The second staff is a guitar accompaniment line in treble clef, featuring a complex, rhythmic pattern of eighth and sixteenth notes. The third staff is a guitar accompaniment line in treble clef, showing a melodic line with some chromaticism. The fourth staff is a guitar accompaniment line in treble clef, consisting of block chords. The fifth staff is a guitar accompaniment line in bass clef, providing a bass line with eighth and sixteenth notes.



The second system of the musical score consists of five staves. The top staff is a vocal line in treble clef, which is mostly empty with some rests. The second staff is a guitar accompaniment line in treble clef, continuing the complex rhythmic pattern from the first system. The third staff is a guitar accompaniment line in treble clef, continuing the melodic line. The fourth staff is a guitar accompaniment line in treble clef, continuing the block chord accompaniment. The fifth staff is a guitar accompaniment line in bass clef, continuing the bass line.



The first system of music consists of five staves. The top staff is a blank treble clef staff with a key signature of three sharps (F#, C#, G#). The second staff contains a complex melodic line with many sixteenth and thirty-second notes. The third staff contains a series of chords and dyads. The fourth staff contains a steady eighth-note accompaniment. The fifth staff is a bass clef staff with a sparse bass line.



The second system of music consists of five staves. The top staff is a blank treble clef staff with a key signature of three sharps (F#, C#, G#). The second staff continues the complex melodic line from the first system. The third staff continues the chordal accompaniment. The fourth staff continues the eighth-note accompaniment. The fifth staff continues the bass line.



Inlet Sun

Composer: Paul William Engholm

♩ = 120



Walk a - long the beach and see the tide roll in the
As you walk a - long the beach and think of what might

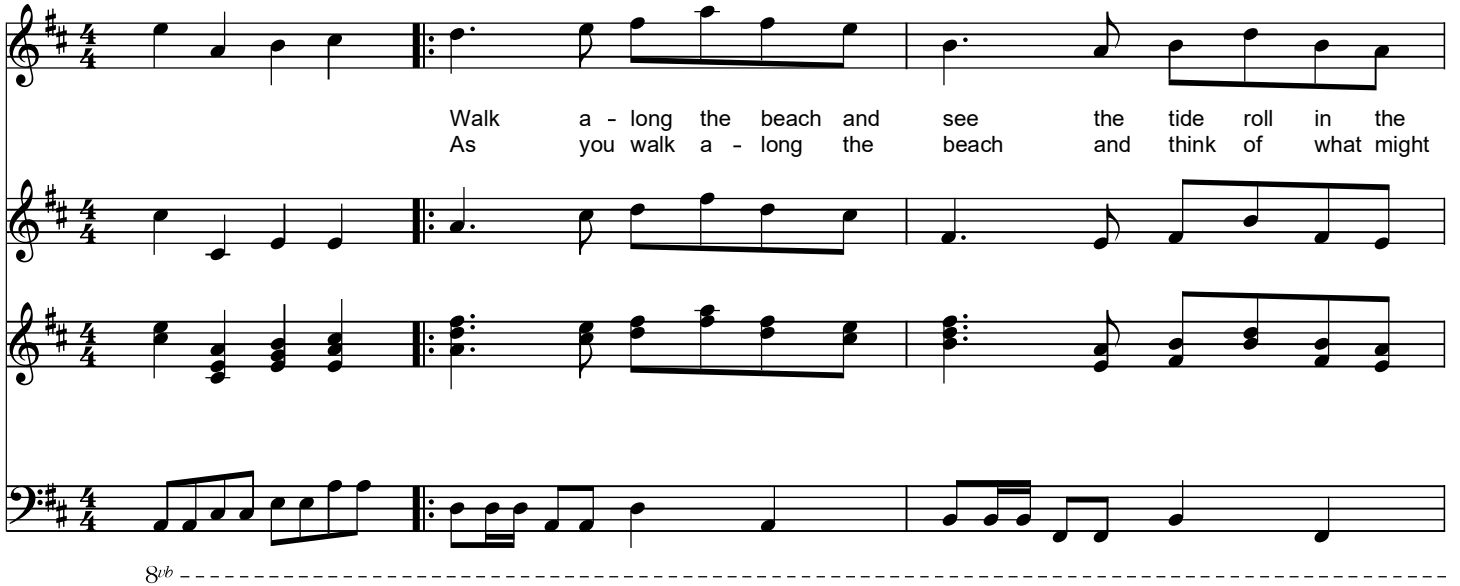

8^{va} -----



bay it rush - es to the shore As the sun be - gins to
be when some - one real - ly shares Like the hands of those that



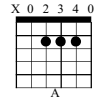
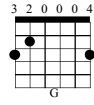
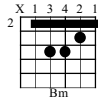

rise and all your cares just and seem to slip a - way like waves
 heal the Earth and Sky and Sea for - e - ver that is there

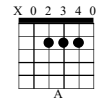
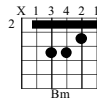

Then you think a - bout a love you a love so great it
 Chance like this comes true for who find that love is

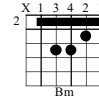
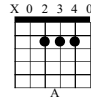
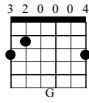

seems just like a dream come true Like the whis - per of the
 true when love has first be - gun As the joy of love so

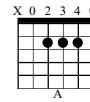
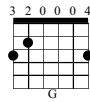
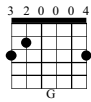

sea the whis - per that you hear is say - ing "Love is true"
 much re - turns you to the Sun the In - let in the Sun

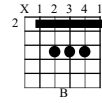
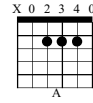
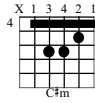
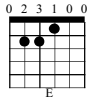

First system of musical notation, including treble and bass staves with chord diagrams above.

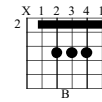
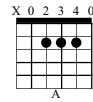
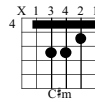
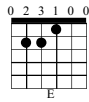

Second system of musical notation, including treble and bass staves with chord diagrams above.

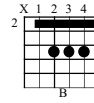
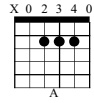
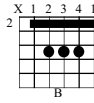
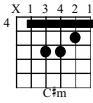

First system of musical notation, including treble and bass staves with chord diagrams for Cm, B, and A.

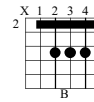
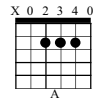
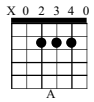
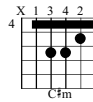

Second system of musical notation, including treble and bass staves with chord diagrams for Cm, A, and B.

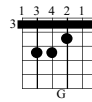
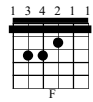
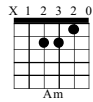
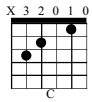
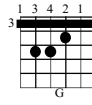
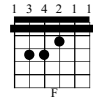
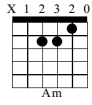
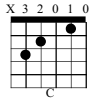

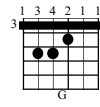
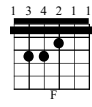
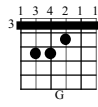
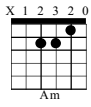

First system of musical notation, consisting of four staves (treble, two middle, and bass clefs).

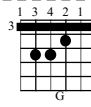
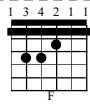
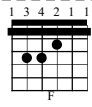
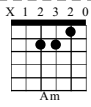

Second system of musical notation, consisting of four staves (treble, two middle, and bass clefs), ending with double bar lines and repeat dots.

Magic Theme

Composer: Paul William Engholm

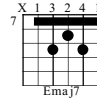
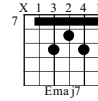
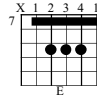
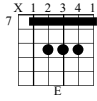

♩ = 120

I came up - on this scene _____
A realm of now and yore _____
Where time e - tern - al lies _____

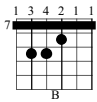
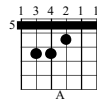
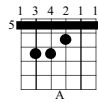
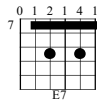
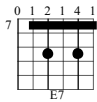

Where fan - ta - sy is gleaned _____
A wo - nder that is more _____
With - in the man - y rhymes _____

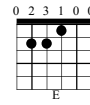
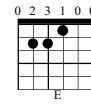
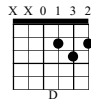
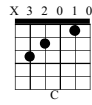
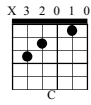

I found the end - less dream _____
 A place that I a - dore _____
 Of all the songs we write _____

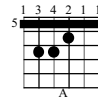
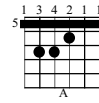
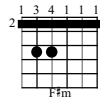
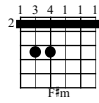

That leads in - to this peace _____
 A place where mus - ic soars _____
 As sung through - out all time _____

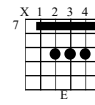
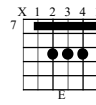
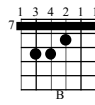
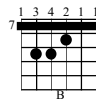
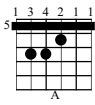
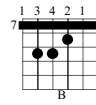
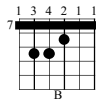
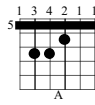
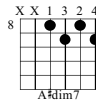
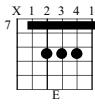

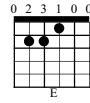
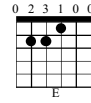
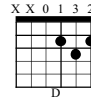
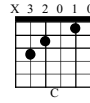
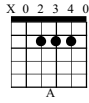
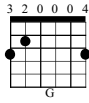
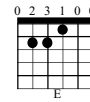
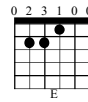
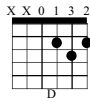
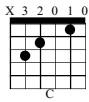
My 1st Song

Composer: Paul William Engholm

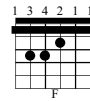
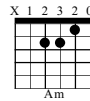
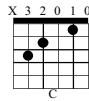

♩ = 120

This is my ver - y first ___ song It might be

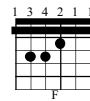
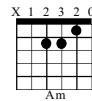
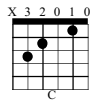
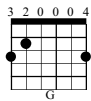

sim - ple and not long It is the ver - y first I played When I was

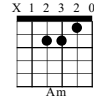
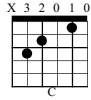
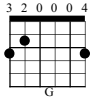

ver - y young of age And it still sounds the same Through all the years I play

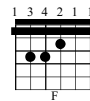
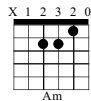
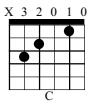

And it will still re - main The one I learned that day On through - out all of

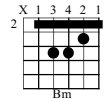
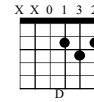
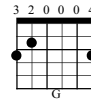
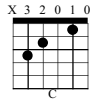
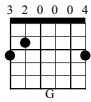

time My ver - y first song

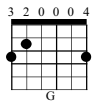
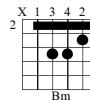
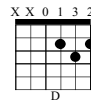
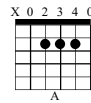
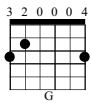

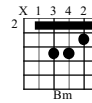
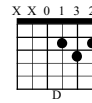
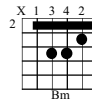
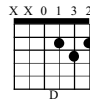
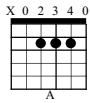

Musical notation for the first system, including treble and bass staves with chords and melodic lines.

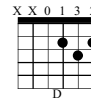
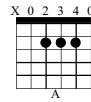
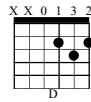
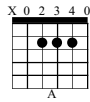
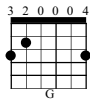

Musical notation for the second system, including treble and bass staves with chords and melodic lines, featuring first and second endings.

Passing Fancy

Composer: Paul William Engholm

X X 0 1 3 2 X 0 2 3 4 0 3 2 0 0 4 X X 0 1 3 2 X 0 2 3 4 0 3 2 0 0 4

D A G D A G

♩ = 120

Take a ride for free on your own two feet
Trav - el life with ease make it light and free
Trav - el life with ease make it light and free

X X 0 1 3 2 X 0 2 3 4 0 X 2 1 0 3 X X X 0 1 0 2

D A Cadd9 Ddim7

Trav - el light wear a smile in the grace of all Love and your
Make a plan to be kind with your help - ing hands Be hap - py
Make a plan to be kind with your help - ing hands Be hap - py

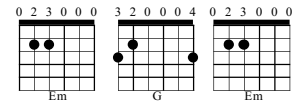
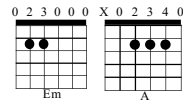
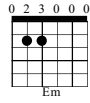
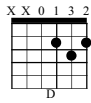

true com - pass - ion Just a pass - ing fan - cy in the eyes of
 and se - rene — Just a pass - ing fan - cy in the eyes of
 and se - rene — Just a pass - ing fan - cy in the eyes of

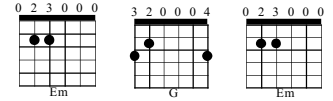
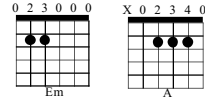
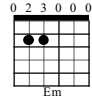
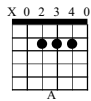

Da ⊕

all Just a pass - ing fan - cy wait - ing to be
 all Just a pass - ing fan - cy wait - ing to be
 all Just a pass - ing fan - cy wait - ing to be

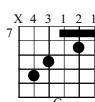
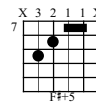
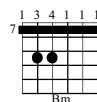
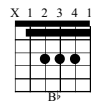
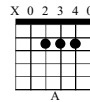
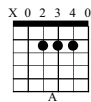

1. 2.
 found found As a sign of im - mort - al love one that nev - er

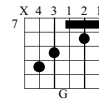
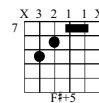
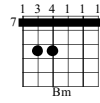
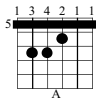

ends Love you give is love re - ceived all the love you



Da Capo Al Coda ⊕ ⊕

send found As a sign of im - mort - al love



one that nev - er ends Love you give is love re - ceived

Savor Favor

Composer: Paul William Engholm

♩ = 120

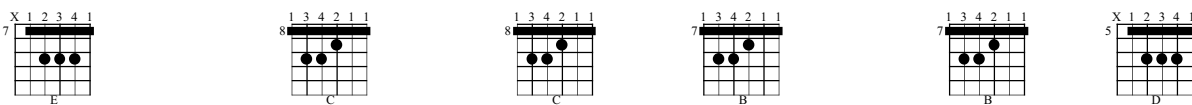

Fav - or my friend _____ is a gift _____ you can send _
Fav - or my friend _____ is a means _____ to an end _

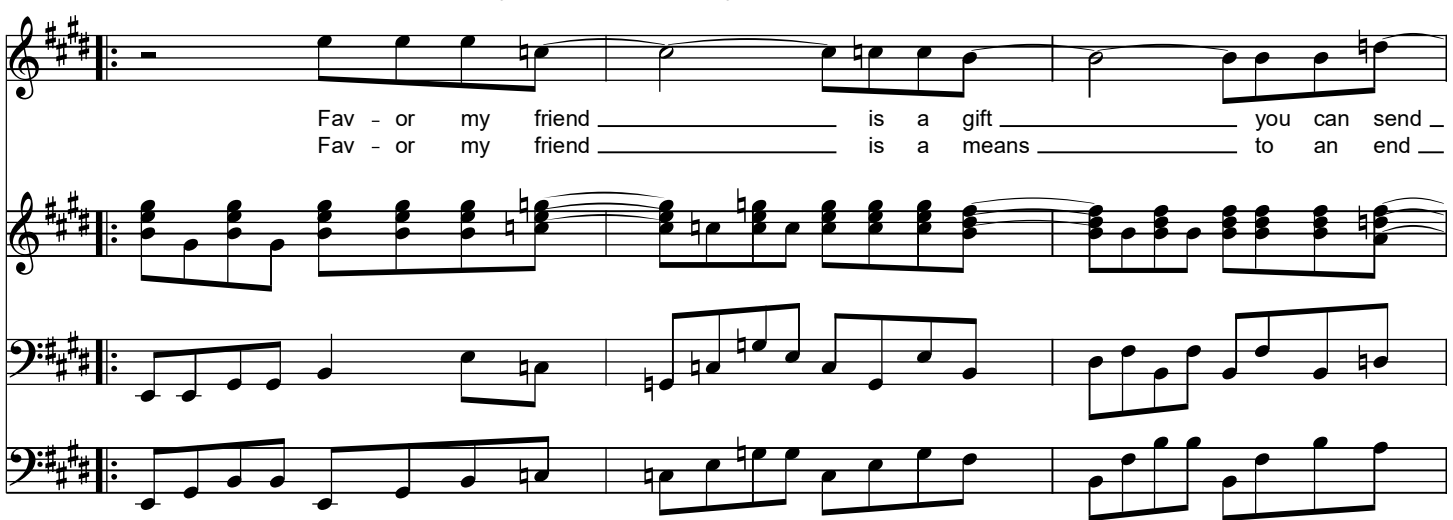

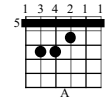
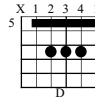
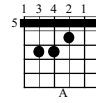
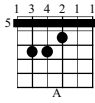
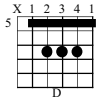
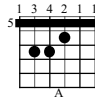
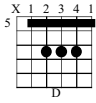

when you lend a help - ing
 when you send you send good

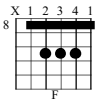
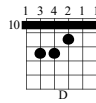
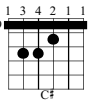
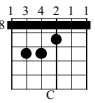
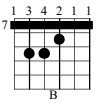
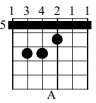
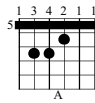
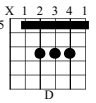
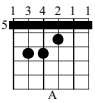

hand _____ It's a good deed _
 will _____ Care for a need _

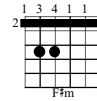
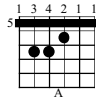
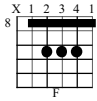

and a sign Of some -
and you find That a

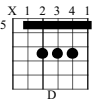
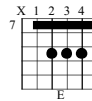
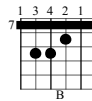
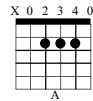
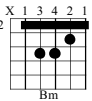
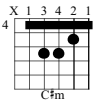
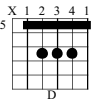

- one who real - ly cares right for the world and
fav - or makes things right for all time

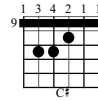
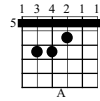
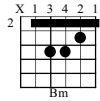
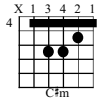

peo - ple Some - times you find
 Fav - or is fine

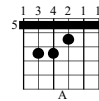
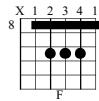
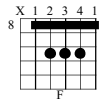
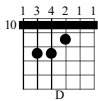

giv - ing help is so kind Sav - or this
 with a sav - or sub - lime Fav - or life

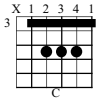
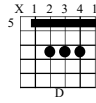
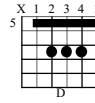
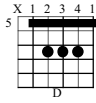
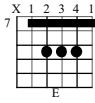

in you mind
yours and mine

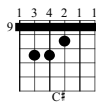
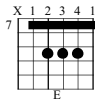
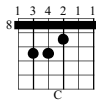
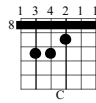
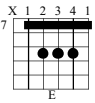

Just like the full moon
smiling bright in the night



— Fav - or is the sav - or of life —

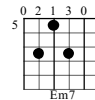
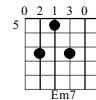
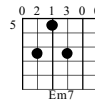
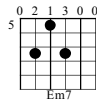
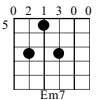

x4 *x3*

Toys 2 Love

Composer: Paul William Engholm

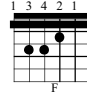
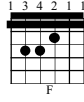

♩ = 120

We were young and goes
As the time goes

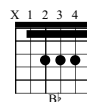
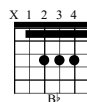

played with toys and life was so much fun and then we grew and fell in
on it seems like yes - ter - day that we were young and we still play the



love and then we knew as one to - geth - er we'd be true al - ways
 games that bring us joy and keep us young at heart for - ev - er - more



Boy and girl who lived next door and all my toys were yours and the
 E - ven now we share and cher - ish one an - oth - er like the

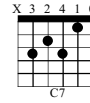
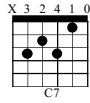
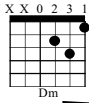

then your hand was mine the one that I a - dore and al - ways will un -
 day we met and we are friends and love will guide and keep us safe for

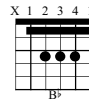
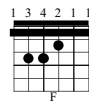
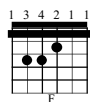
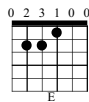
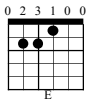

- til the end of time
 all e - ter - ni - ty

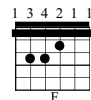
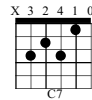
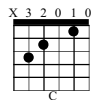
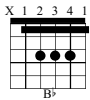

First system of musical notation, including a grand staff (treble and bass clefs) and four individual staves. The notation features a bass line and three treble staves. The first treble staff contains a melodic line with triplets. The second and third treble staves contain a similar melodic line with triplets. The fourth treble staff contains a chordal accompaniment. The bass line contains a rhythmic accompaniment.

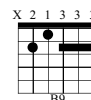
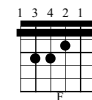
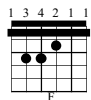
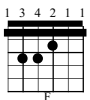

Second system of musical notation, including a grand staff (treble and bass clefs) and four individual staves. The notation features a bass line and three treble staves. The first treble staff contains a melodic line with triplets. The second and third treble staves contain a similar melodic line with triplets. The fourth treble staff contains a chordal accompaniment. The bass line contains a rhythmic accompaniment.

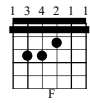
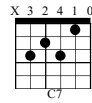
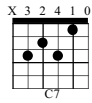
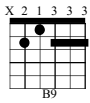

Musical score for the first system, featuring six staves. The top staff is a grand staff with treble and bass clefs. The second and third staves are treble clefs. The fourth staff is a treble clef. The fifth staff is a treble clef. The sixth staff is a bass clef. The music includes triplets and various rhythmic patterns.

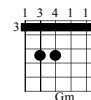
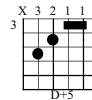
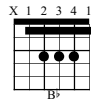
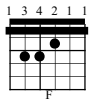

Musical score for the second system, featuring six staves. The top staff is a grand staff with treble and bass clefs. The second and third staves are treble clefs. The fourth staff is a treble clef. The fifth staff is a treble clef. The sixth staff is a bass clef. The music includes triplets and various rhythmic patterns, with a key signature change to one sharp.

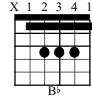
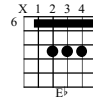
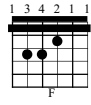
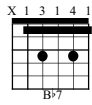

Musical notation for the first system, including treble and bass staves with various chord diagrams above.

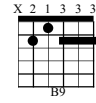
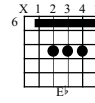
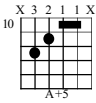
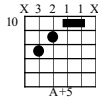
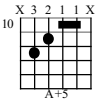

Musical notation for the second system, including treble and bass staves with various chord diagrams above and triplets.

TruthFinder

Composer: Paul William Engholm

X 3 2 0 1 0 3 2 0 0 0 4 0 2 3 0 0 0 1 3 4 2 1 1 3 2 0 0 0 4

C G Em F G

♩ = 120

Bring truth to light so that you can

X 1 2 3 2 0 X 1 2 3 2 0 3 2 0 0 0 4 1 3 4 2 1 1 X X 0 2 3 1 3 2 0 0 0 4

Am Am G F Dm G

see Be - lieve in right so that you are

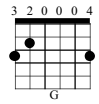
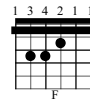
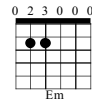
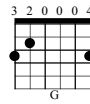
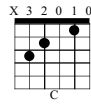
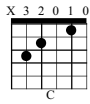

free Use all your sight so that you can

The first system of music consists of four staves. The top staff is a vocal line with lyrics: "free Use all your sight so that you can". The second staff is a vocal line. The third staff is a guitar accompaniment line with chords. The bottom staff is a bass line.

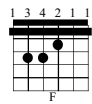
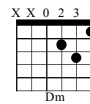
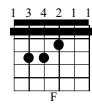
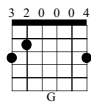
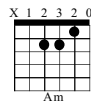
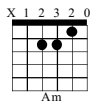

be Filled with the might so that all a -

The second system of music consists of four staves. The top staff is a vocal line with lyrics: "be Filled with the might so that all a -". The second staff is a vocal line. The third staff is a guitar accompaniment line with chords. The bottom staff is a bass line.

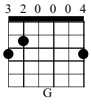
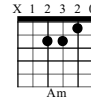
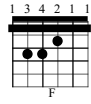
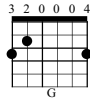
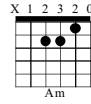
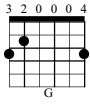

- gree Peace on Earth is grow · ing e - very - where we

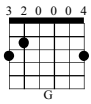
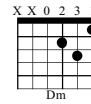
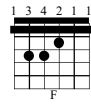
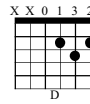
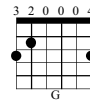
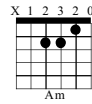
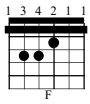

go If we just take a look I'm sure it will

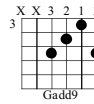
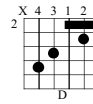
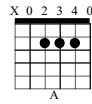
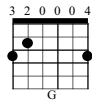
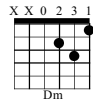
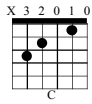

show more than we will know

The first system of the musical score consists of four staves. The top two staves are vocal lines, with the lyrics "show more than we will know" written below the first staff. The third staff is the guitar accompaniment in treble clef, and the fourth staff is the bass line in bass clef. The music is in a key with one sharp (F#) and a 4/4 time signature.

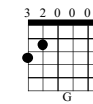
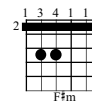
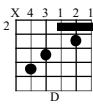
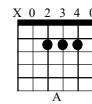
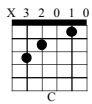
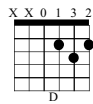
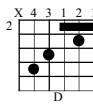
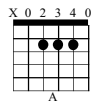

The second system of the musical score consists of four staves. The top two staves are empty, indicating a rest for the vocalists. The third staff is the guitar accompaniment in treble clef, and the fourth staff is the bass line in bass clef. The music continues in the same key and time signature as the first system.

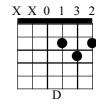
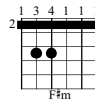
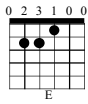
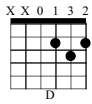

Hap - py all the time

The first system of the musical score consists of four staves. The top two staves are vocal lines in treble clef, with lyrics "Hap - py all the time" written below them. The third staff is the guitar melody in treble clef, and the fourth staff is the bass line in bass clef. The key signature has one sharp (F#), and the time signature is 4/4. The music begins with a whole rest in the vocal lines, followed by a half note G4, a quarter note A4, and a half note B4. The guitar accompaniment features a series of chords and a melodic line.

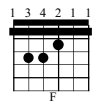
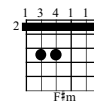
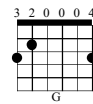
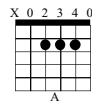
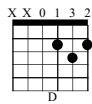
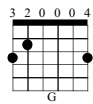
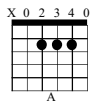

Da ☺

har - mon y and rhyme Sing with a joy - ous voice

The second system of the musical score consists of four staves. The top two staves are vocal lines in treble clef, with lyrics "har - mon y and rhyme Sing with a joy - ous voice" written below them. The third staff is the guitar melody in treble clef, and the fourth staff is the bass line in bass clef. The key signature has one sharp (F#), and the time signature is 4/4. The music begins with a whole rest in the vocal lines, followed by a half note G4, a quarter note A4, and a half note B4. The guitar accompaniment features a series of chords and a melodic line.

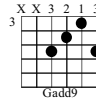
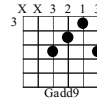
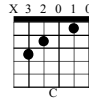
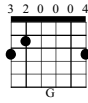
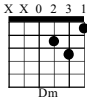

Dal Segno S *Al Coda* C C

heard through - out all Time

The first system of the musical score consists of four staves. The top staff is a vocal line with lyrics "heard through - out all Time". The second staff is a guitar accompaniment line with chords and melodic lines. The third staff is a bass line with a rhythmic pattern. The fourth staff is a guitar accompaniment line with chords and melodic lines.

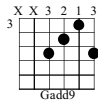
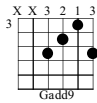

The second system of the musical score consists of four staves. The top staff is a vocal line with a long note. The second staff is a guitar accompaniment line with chords and melodic lines. The third staff is a bass line with a rhythmic pattern. The fourth staff is a guitar accompaniment line with chords and melodic lines.

Instrumental Scores

CelebraTune

Composer: Paul William Engholm

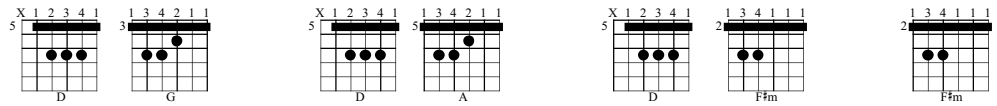

♩ = 120

First system of musical notation, including treble, guitar, and bass staves.

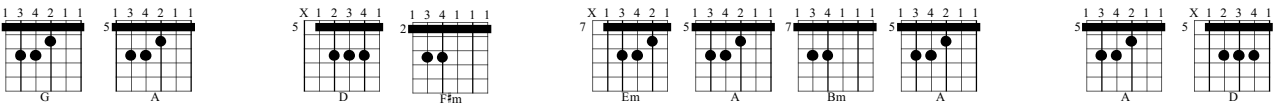

Second system of musical notation, including treble, guitar, and bass staves.

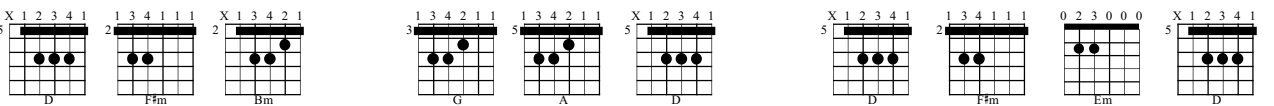

Third system of musical notation, including treble, guitar, and bass staves.

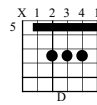
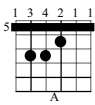
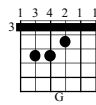
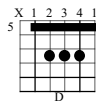
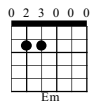
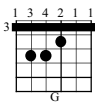
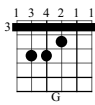

1.

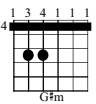
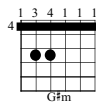
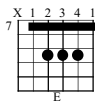
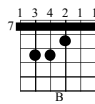
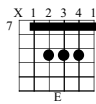
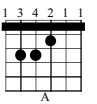
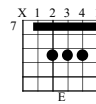
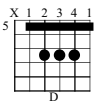

2.

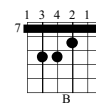
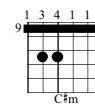
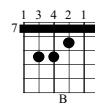
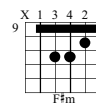
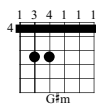
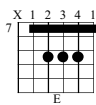
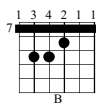
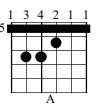

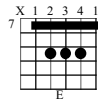
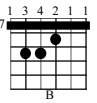
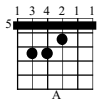
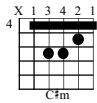
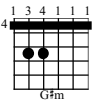
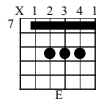
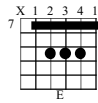
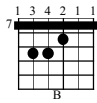

First system of musical notation, including treble, guitar, and bass staves.

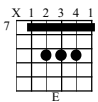
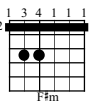
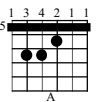
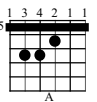
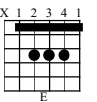
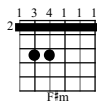
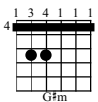
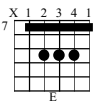

Second system of musical notation, including treble, guitar, and bass staves.

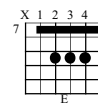
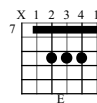
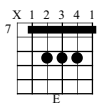
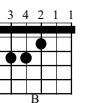
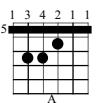

Third system of musical notation, including treble, guitar, and bass staves, with first and second endings.

FalconFlight

Composer: Paul William Engholm

1 3 4 1 1 1
5
Am

X 3 2 1 1 X
5
E+5

X 1 2 3 4 1
3
C

X 2 1 3 3 3
4
D9

♩ = 120

X X 1 3 3 3
3
Fmaj7

X X 1 3 2 4
2
E7

1 3 4 1 1 1
5
Am

1 3 4 1 1 1
4
Gfm

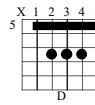
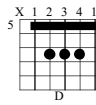
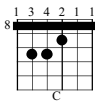
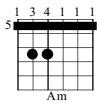

The first system of music consists of four staves. The top staff shows a sequence of chords: Am, C, D, D, D, D, D, D, D, D, D, D. The second staff contains a melodic line with triplets of eighth notes. The third staff shows a series of chords: Am, C, D, D, D, D, D, D, D, D, D, D. The bottom staff is a bass line with eighth notes.

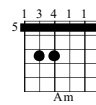
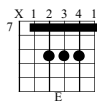
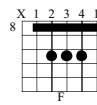

The second system of music consists of four staves. The top staff shows a sequence of chords: F, E, Am, G#m, G#m, G#m, G#m, G#m, G#m, G#m, G#m, G#m. The second staff contains a melodic line with triplets of eighth notes. The third staff shows a series of chords: F, E, Am, G#m, G#m, G#m, G#m, G#m, G#m, G#m, G#m, G#m. The bottom staff is a bass line with eighth notes.

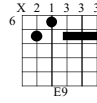
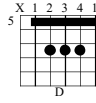
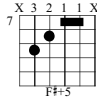
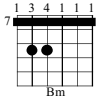

Musical score for the first system, featuring four staves: Treble (melody), Treble (triplets), Treble (chords), and Bass (bass line). The key signature is two sharps (F# and C#).

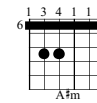
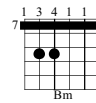
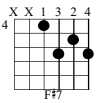
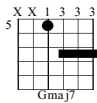

Musical score for the second system, featuring four staves: Treble (melody), Treble (triplets), Treble (chords), and Bass (bass line). The key signature changes to one sharp (F#).

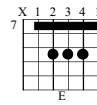
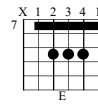
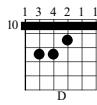
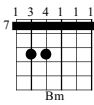

The first system of music consists of four staves. The top staff is a treble clef with a key signature of two sharps (F# and C#). It contains a series of chords: Bm, D, E, and E. The second and third staves are also treble clefs, with the second staff featuring triplets of eighth notes and the third staff featuring chords. The bottom staff is a bass clef with a key signature of two sharps, containing a bass line with eighth and sixteenth notes.

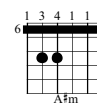
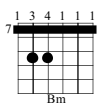
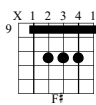
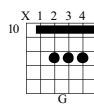

The second system of music consists of four staves. The top staff is a treble clef with a key signature of two sharps. It contains a series of chords: G, F#, Bm, and A#m. The second and third staves are also treble clefs, with the second staff featuring triplets of eighth notes and the third staff featuring chords. The bottom staff is a bass clef with a key signature of two sharps, containing a bass line with eighth and sixteenth notes.

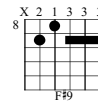
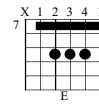
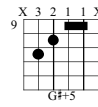
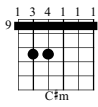

Musical notation for the first system, including treble and bass staves with various chord voicings and triplets.

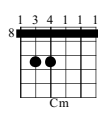
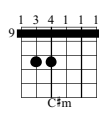
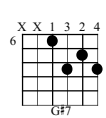
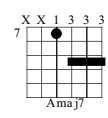

Musical notation for the second system, including treble and bass staves with various chord voicings and triplets.

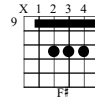
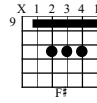
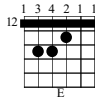
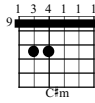

First system of musical notation, including treble and bass staves with chords and triplets.

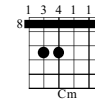
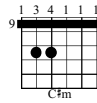
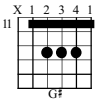
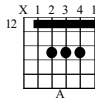

Second system of musical notation, including treble and bass staves with chords and triplets.

HauntinGale

Composer: Paul William Engholm

♩ = 120

Am F Am F Am F

D9 Bm7/5 C+5

Am F D#5 E7 A(maj7) F(maj7)

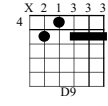
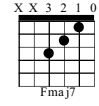
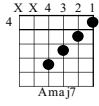
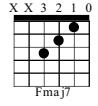
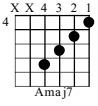

Musical notation for the first system, including treble, guitar, and bass staves.

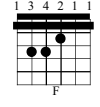
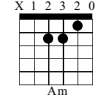
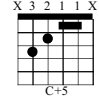
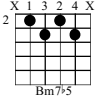

Musical notation for the second system, including treble, guitar, and bass staves.

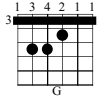
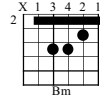
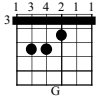
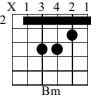
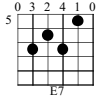
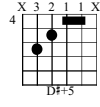

Musical notation for the third system, including treble, guitar, and bass staves.

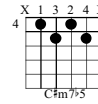
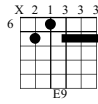
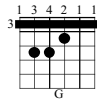
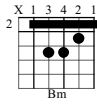

First system of musical notation, including treble, guitar, and bass staves.

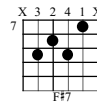
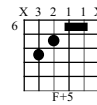
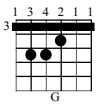
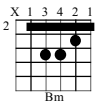
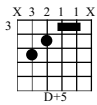

Second system of musical notation, including treble, guitar, and bass staves.

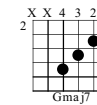
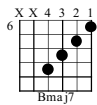
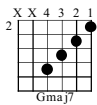
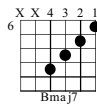
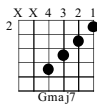
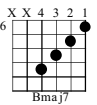

Third system of musical notation, including treble, guitar, and bass staves.

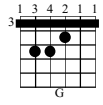
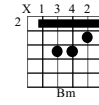
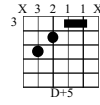
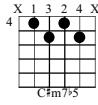
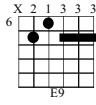

First system of musical notation, including treble and bass staves.

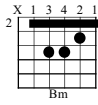
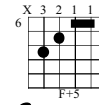
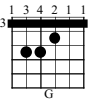
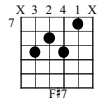
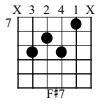
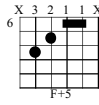

Second system of musical notation, including treble and bass staves.

Horizoneer

Composer: Paul William Engholm

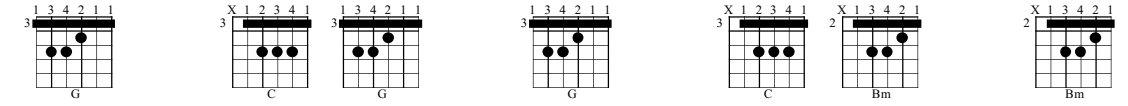

♩ = 120

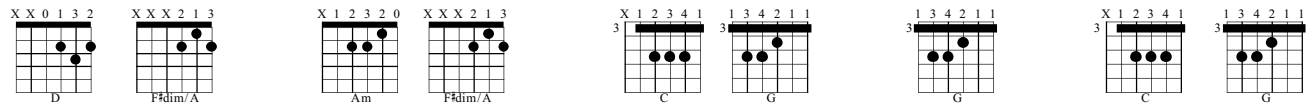
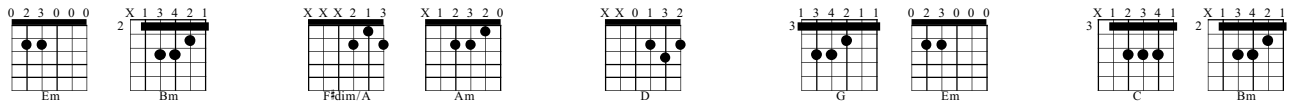

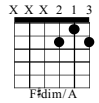
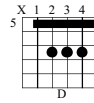
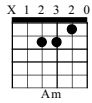
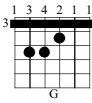
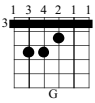
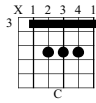
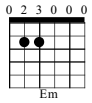

Da \oplus

$\text{♩} = 160$

Dal Segno S *Al Coda* \oplus \oplus

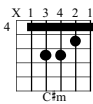
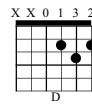
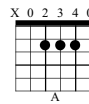
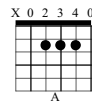
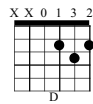
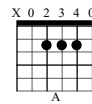
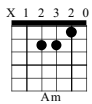

$\text{♩} = 120$

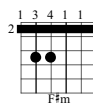
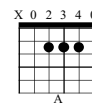
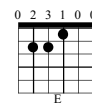
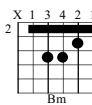
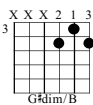
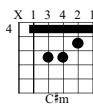
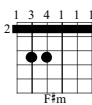
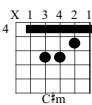

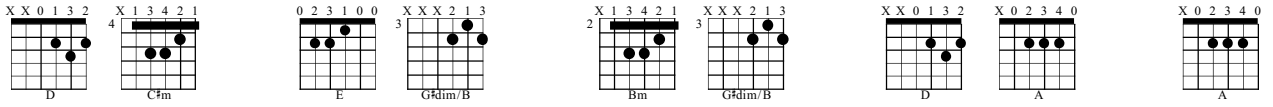

Musical notation for the first system, including treble, guitar, and bass staves. The key signature is two sharps (F# and C#). The guitar staff shows a melodic line with eighth and quarter notes. The bass staff shows a bass line with quarter and eighth notes.

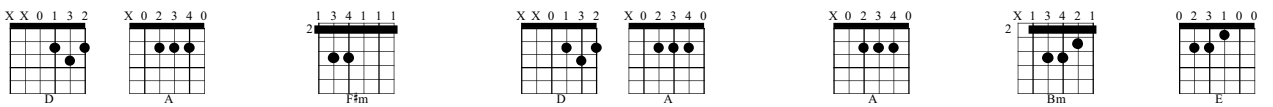

Musical notation for the second system, including treble, guitar, and bass staves. The key signature is two sharps (F# and C#). The tempo is marked as ♩ = 160. The time signature changes to 3/4. The guitar staff shows a melodic line with eighth and quarter notes. The bass staff shows a bass line with quarter and eighth notes.

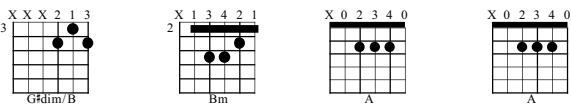

Musical notation for the third system, including treble, guitar, and bass staves. The key signature is two sharps (F# and C#). The guitar staff shows a melodic line with eighth and quarter notes. The bass staff shows a bass line with quarter and eighth notes.

LoveSight

Composer: Paul William Engholm

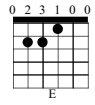
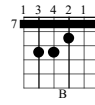
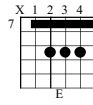
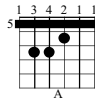
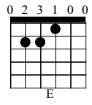

♩ = 120

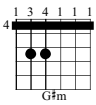
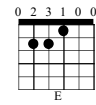
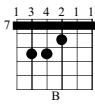
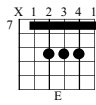
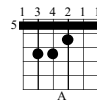
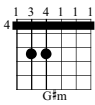

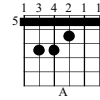
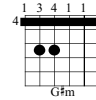
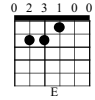
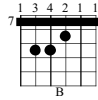
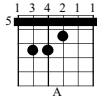

The first system of music consists of four staves. The top staff is a treble clef with a key signature of three sharps (F#, C#, G#) and a common time signature. It contains a melodic line with eighth and quarter notes. The second staff is also a treble clef, providing a harmonic accompaniment with eighth and quarter notes. The third staff is a treble clef showing chord voicings for the first system. The fourth staff is a bass clef with a bass line consisting of quarter and eighth notes.



The second system of music consists of four staves. The top staff is a treble clef with a key signature of three sharps and a common time signature. It contains a melodic line with a repeat sign and a fermata. The second staff is also a treble clef, providing a harmonic accompaniment with eighth and quarter notes. The third staff is a treble clef showing chord voicings for the second system. The fourth staff is a bass clef with a bass line consisting of quarter and eighth notes.

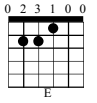
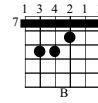
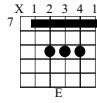
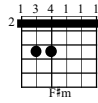
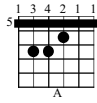
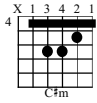

The first system of music consists of four staves. The top staff is a treble clef with a key signature of three sharps (F#, C#, G#) and a 3/4 time signature. It contains a melodic line with some rests. The second staff is also a treble clef with the same key signature and time signature, containing a more active melodic line. The third staff is a treble clef with the same key signature and time signature, containing a series of chords. The fourth staff is a bass clef with the same key signature and time signature, containing a bass line with eighth notes.

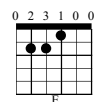
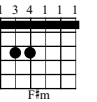
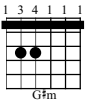
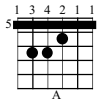
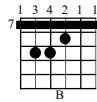
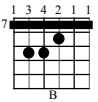
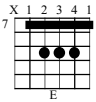
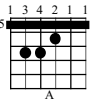
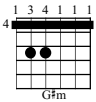

Da \oplus Da Capo Al Coda \oplus \oplus

The second system of music consists of four staves. The top staff is a treble clef with a key signature of three sharps (F#, C#, G#) and a 3/4 time signature. It contains a melodic line with a repeat sign. The second staff is also a treble clef with the same key signature and time signature, containing a more active melodic line with a repeat sign. The third staff is a treble clef with the same key signature and time signature, containing a series of chords with a repeat sign. The fourth staff is a bass clef with the same key signature and time signature, containing a bass line with eighth notes and a repeat sign.

Majestic March

Composer: Paul William Engholm



$\text{♩} = 120$

First system of musical notation for 'Majestic March', featuring treble, guitar, and bass staves.

Sub

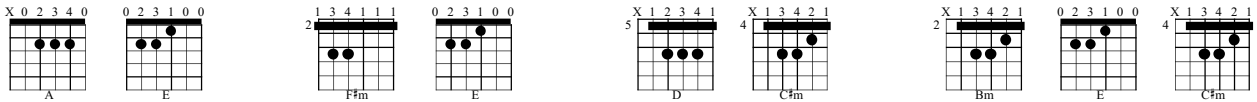

Second system of musical notation for 'Majestic March', featuring treble, guitar, and bass staves.

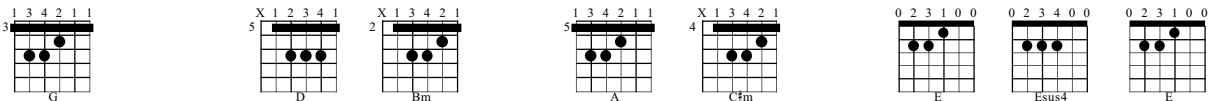

Third system of musical notation for 'Majestic March', featuring treble, guitar, and bass staves.

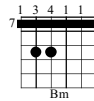
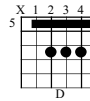
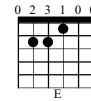
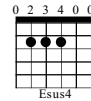
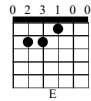
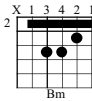
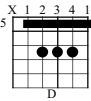
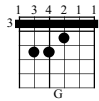

First system of musical notation, including treble, guitar, and bass staves.

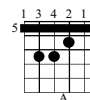
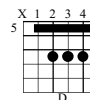
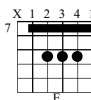
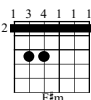
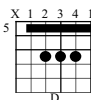
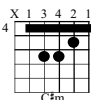
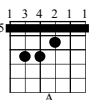
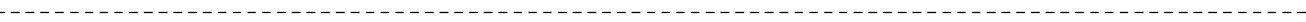

Second system of musical notation, including treble, guitar, and bass staves.

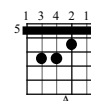
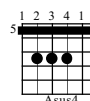
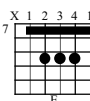
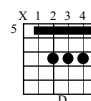
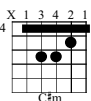
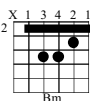
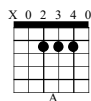
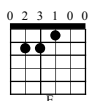
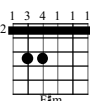
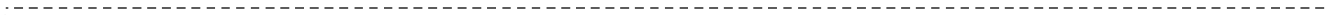

Third system of musical notation, including treble, guitar, and bass staves.





Musical notation for the first system, consisting of three staves: Treble clef (melody), Middle clef (chords), and Bass clef (bass line). The key signature has one flat (Bb) and the time signature is 3/4. The melody starts with a quarter rest, followed by quarter notes G4, A4, Bb4, and eighth notes G4, F4, E4, D4. The bass line follows a similar pattern: quarter notes G2, A2, Bb2, and eighth notes G2, F2, E2, D2. The middle staff shows chords: C, G, Am, G, C, G, Am, G.

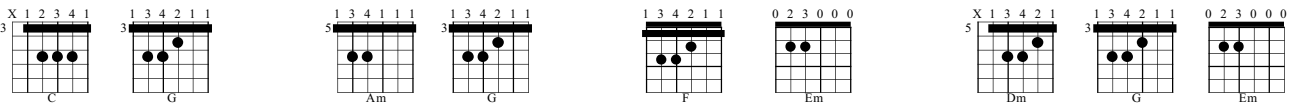

Musical notation for the second system, consisting of three staves. The melody continues with quarter notes C5, Bb4, A4, G4, F4, E4, D4, C4. The bass line continues with quarter notes C2, Bb1, A1, G1, F1, E1, D1, C1. The middle staff shows chords: C, G, Am, G, F, Em, Dm, G, Em.

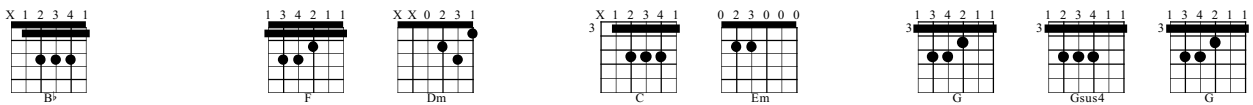

Musical notation for the third system, consisting of three staves. The melody continues with quarter notes Bb4, A4, G4, F4, E4, D4, C4, Bb4. The bass line continues with quarter notes Bb1, A1, G1, F1, E1, D1, C1, Bb1. The middle staff shows chords: Bb, F, Dm, C, Em, G, Gsus4, G.

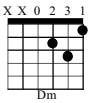
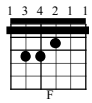
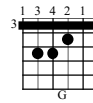
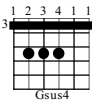
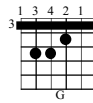
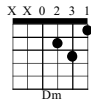
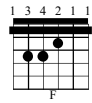
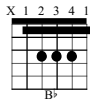

Musical notation for the first system, including treble, guitar, and bass staves.

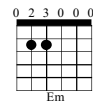
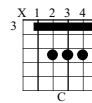
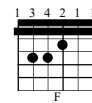
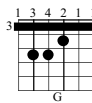
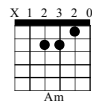
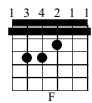
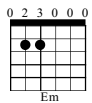
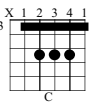

Musical notation for the second system, including treble, guitar, and bass staves.

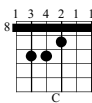
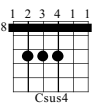
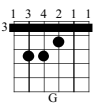
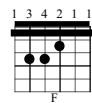
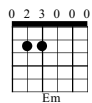
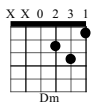
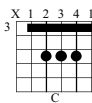
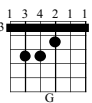
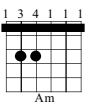

Musical notation for the third system, including treble, guitar, and bass staves.

Mirage Mirror

Composer: Paul William Engholm

♩ = 120

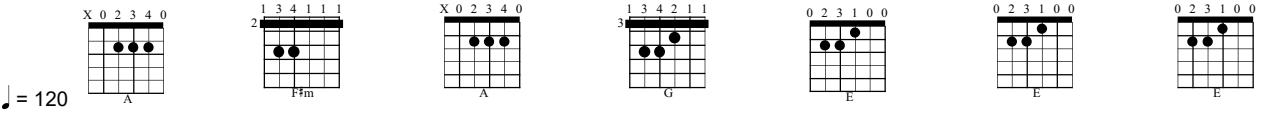

A F#m A G E E E

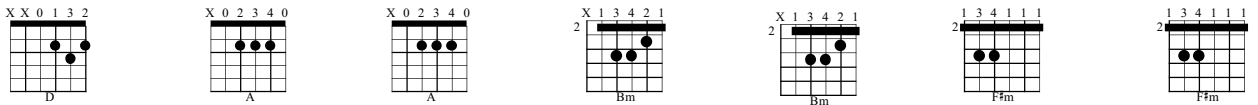

D A A Bm Bm F#m F#m



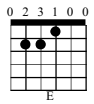
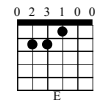
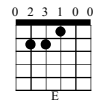
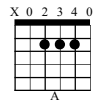
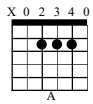
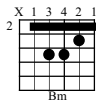
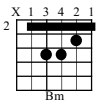

The first system of the musical score consists of four staves. The top two staves are in treble clef with a key signature of two sharps (F# and C#). The bottom two staves are in bass clef with the same key signature. The music is written in a 4/4 time signature. Above the first two staves, there are seven guitar chord diagrams corresponding to the notes in the melody. The chords are: Bm (X 1 3 4 2 1), Bm (X 1 3 4 2 1), A (X 0 2 3 4 0), A (X 0 2 3 4 0), E (0 2 3 1 0 0), E (0 2 3 1 0 0), and E (0 2 3 1 0 0).

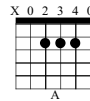
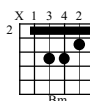
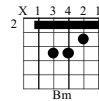
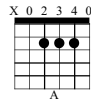
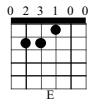
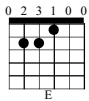

The second system of the musical score consists of four staves. The top two staves are in treble clef with a key signature of two sharps (F# and C#). The bottom two staves are in bass clef with the same key signature. The music is written in a 4/4 time signature. Above the first two staves, there are six guitar chord diagrams corresponding to the notes in the melody. The chords are: E (0 2 3 1 0 0), E (0 2 3 1 0 0), A (X 0 2 3 4 0), Bm (X 1 3 4 2 1), Bm (X 1 3 4 2 1), and A (X 0 2 3 4 0).

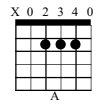
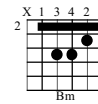
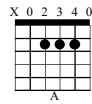
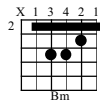
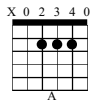

Musical score for the first system, featuring four staves (treble and bass clefs) with a key signature of two sharps (F# and C#). The score includes a melody line, a harmony line, and a bass line. The melody consists of eighth and quarter notes, while the harmony and bass lines provide accompaniment with chords and single notes.

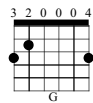
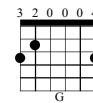
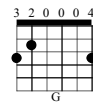
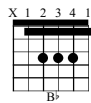
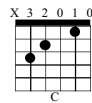
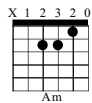
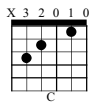

Musical score for the second system, featuring four staves (treble and bass clefs) with a key signature of one flat (Bb and Eb). The score includes a melody line, a harmony line, and a bass line. The melody consists of eighth and quarter notes, while the harmony and bass lines provide accompaniment with chords and single notes.

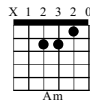
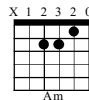
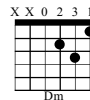
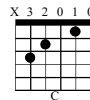
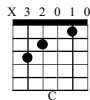
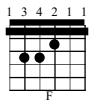

The first system of music consists of four staves. The top staff is a treble clef with a whole note chord F, followed by a half note chord C, and another whole note chord C. The second staff is a treble clef with a half note chord Dm, followed by a half note chord Dm, and another half note chord Am. The third staff is a treble clef with a whole note chord Am, followed by a whole note chord Am. The fourth staff is a bass clef with a half note chord F, followed by a half note chord C, and another half note chord C.



The second system of music consists of four staves. The top staff is a treble clef with a half note chord Dm, followed by a half note chord Dm, and another half note chord C. The second staff is a treble clef with a half note chord C, followed by a half note chord Bb, and another half note chord Bb. The third staff is a treble clef with a whole note chord Bb, followed by a whole note chord Bb. The fourth staff is a bass clef with a half note chord Dm, followed by a half note chord Dm, and another half note chord C.

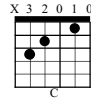
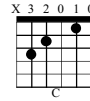
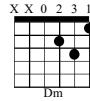
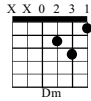
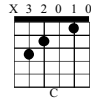
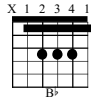
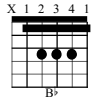

The first system of the musical score consists of four staves. The top staff is a treble clef with a melody of eighth and quarter notes. The second staff is a guitar staff with a treble clef, showing a melodic line with some triplets. The third staff is a guitar staff with a treble clef, showing a chordal accompaniment with various chords and textures. The bottom staff is a bass clef with a bass line of eighth and quarter notes.

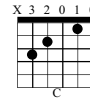
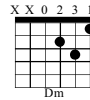
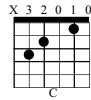
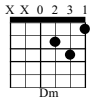

The second system of the musical score consists of four staves. The top staff is a treble clef with a melody of eighth and quarter notes. The second staff is a guitar staff with a treble clef, showing a melodic line with some triplets. The third staff is a guitar staff with a treble clef, showing a chordal accompaniment with various chords and textures. The bottom staff is a bass clef with a bass line of eighth and quarter notes.

Orientalizer

Composer: Paul William Engholm

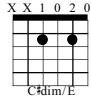
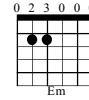
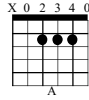
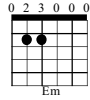

♩ = 120

First system of musical notation for 'Orientalizer'. It consists of three staves: a treble staff with a melody line, a middle treble staff with chords, and a bass staff with a bass line. The key signature is one sharp (F#) and the time signature is 4/4. The tempo is marked as ♩ = 120. The system begins with a repeat sign and ends with a fermata over the final notes.

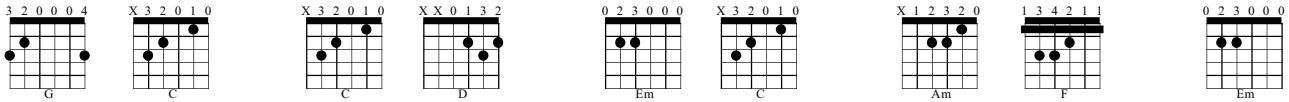

Second system of musical notation for 'Orientalizer'. It consists of three staves: a treble staff with a melody line, a middle treble staff with chords, and a bass staff with a bass line. The notation continues from the first system.

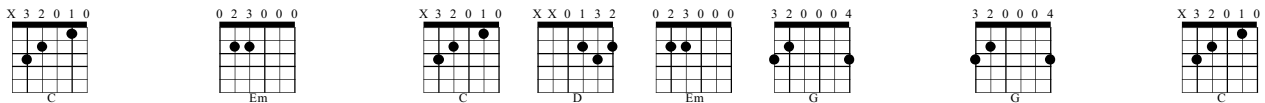

Third system of musical notation for 'Orientalizer'. It consists of three staves: a treble staff with a melody line, a middle treble staff with chords, and a bass staff with a bass line. The notation concludes the piece.

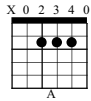
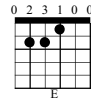
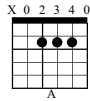
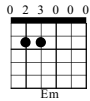
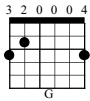

First system of musical notation, including treble, guitar, and bass staves.

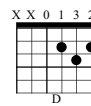
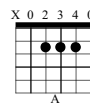
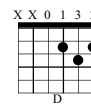
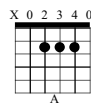
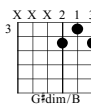
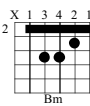
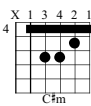
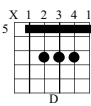

Second system of musical notation, including treble, guitar, and bass staves.

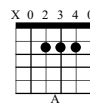
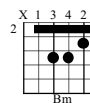
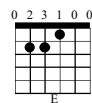
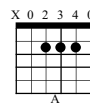
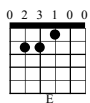

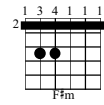
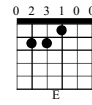
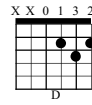
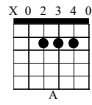
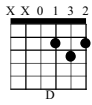

Third system of musical notation, including treble, guitar, and bass staves.

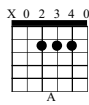
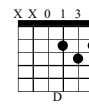
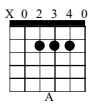
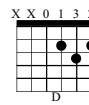
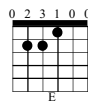
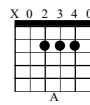
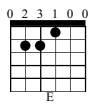
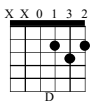

Da ⊕

Musical notation for the first system, including treble and bass staves.



Dal Segno  Al Coda ⊕

Musical notation for the second system, including treble and bass staves.

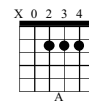
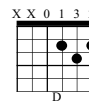
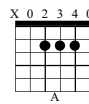
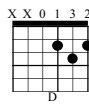
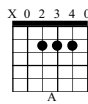

⊕

Musical notation for the third system, including treble and bass staves.

Pause For Five

Composer: Paul William Engholm

X 3 2 0 0 0 0 2 3 0 0 0 X X 0 2 3 1 0 2 3 0 0 0 X 3 2 0 0 0 0 2 3 0 0 0 X X 0 2 3 1 0 2 3 0 0 0

Cmaj7 Em Dm Em Cmaj7 Em Dm Em

♩ = 120

X 3 2 0 0 0 0 2 3 0 0 0 X X 0 2 3 1 0 2 3 0 0 0 X 3 2 0 0 0 0 2 3 0 0 0 X X 0 2 3 1 0 2 3 0 0 0 X X 3 2 1 0 1 3 4 2 1 1 X 1 2 3 2 0

Cmaj7 Em Dm Em Cmaj7 Em Dm Em Fmaj7 G Am

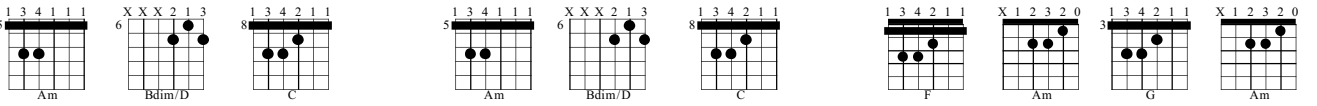
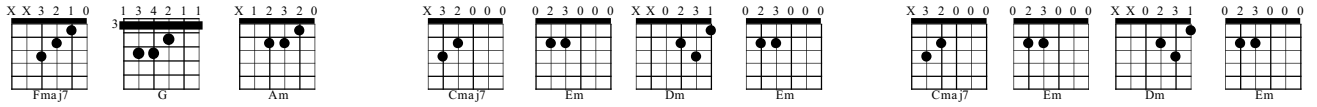

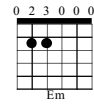
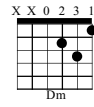
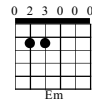
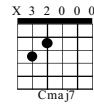
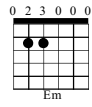
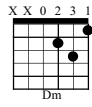
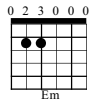
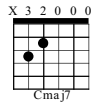

First system of musical notation, including five staves (treble and bass clefs) and guitar chord diagrams for Cmaj7, Em, Dm, and Em.

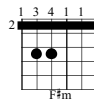
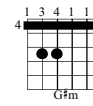
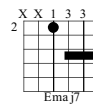
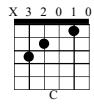
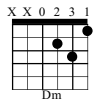
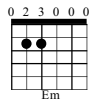
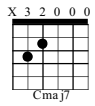

Second system of musical notation, including five staves and guitar chord diagrams for Cmaj7, Em, Dm, C, Ema7, G#m, F#m, and G#m. This system includes a key signature change to three sharps (F#, C#, G#).

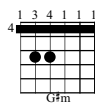
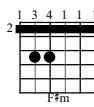
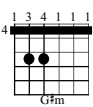
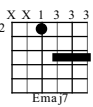
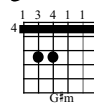
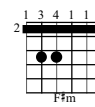
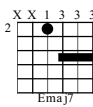

Third system of musical notation, including five staves and guitar chord diagrams for Ema7, G#m, F#m, and G#m. This system continues in the key of three sharps.

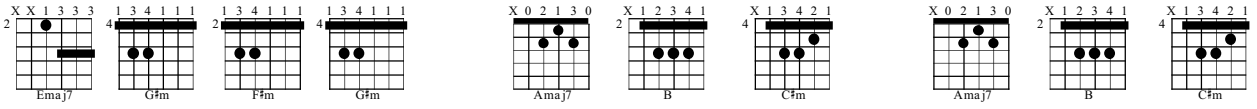

First system of musical notation, including five staves (treble and bass clefs) and a bass line.



Second system of musical notation, including five staves (treble and bass clefs) and a bass line.

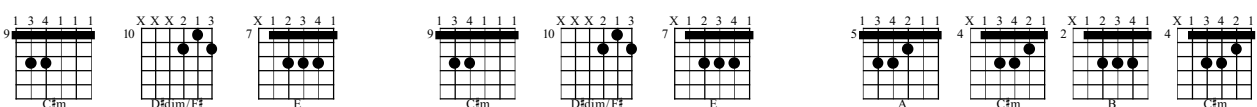

Third system of musical notation, including five staves (treble and bass clefs) and a bass line.

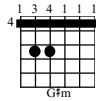
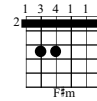
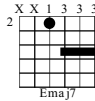
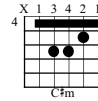
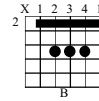
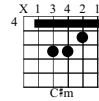
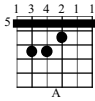

First system of musical notation, including treble and bass staves with chords.

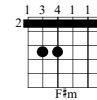
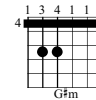
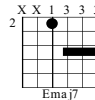
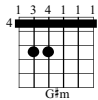
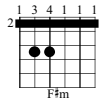
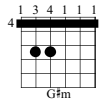
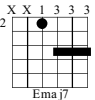

Second system of musical notation, including treble and bass staves with chords.

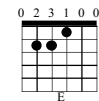
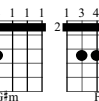
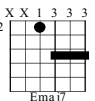

Third system of musical notation, including treble and bass staves with chords.

PranceAlong

Composer: Paul William Engholm

♩ = 120

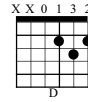
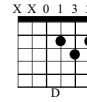
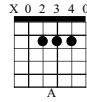
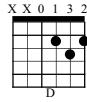
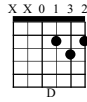
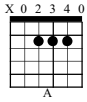

The first system of musical notation consists of four staves. The top staff is the treble clef melody in G major (one sharp) and 4/4 time, starting with a repeat sign. The second staff is the treble clef accompaniment, featuring a rhythmic pattern of eighth and sixteenth notes. The third staff is the treble clef chordal accompaniment, showing chords for A major and D major. The fourth staff is the bass clef accompaniment, showing a simple bass line.

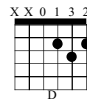
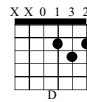
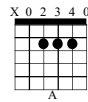
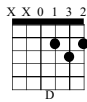
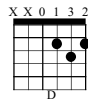
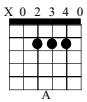

The second system of musical notation is identical in structure to the first system, consisting of four staves (treble melody, treble accompaniment, treble chords, and bass line) in G major and 4/4 time.

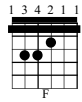
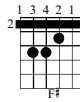
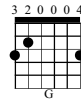
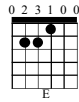
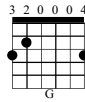
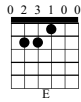
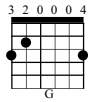
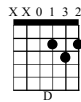
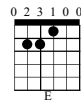
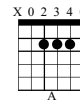
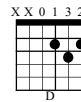
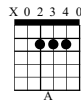
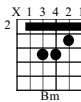
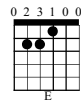
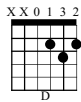
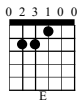

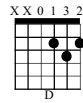
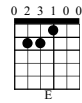
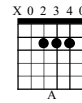
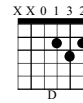
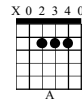
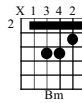
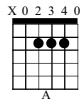
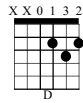
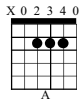
First system of musical notation, including treble and bass staves with chords and melodic lines.

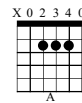
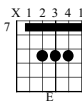
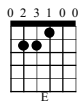
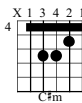
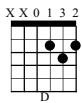
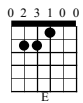

Second system of musical notation, including treble and bass staves with triplets and melodic lines.

RagTime Roller

Composer: Paul William Engholm

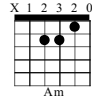
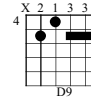
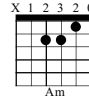
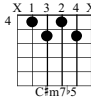
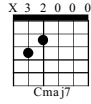
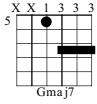

♩ = 120

8vb.

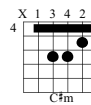
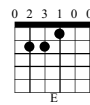
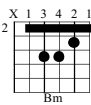
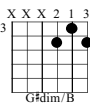
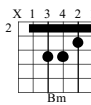
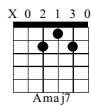
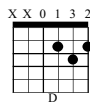
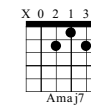
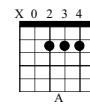
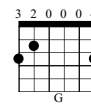
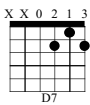
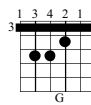
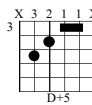
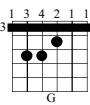

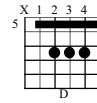
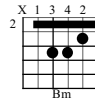
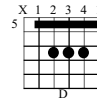
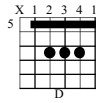
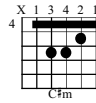
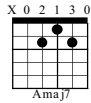
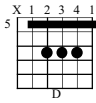

First system of musical notation, including treble, guitar, and bass staves.

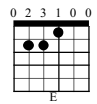
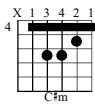
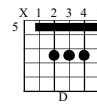
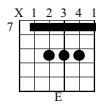
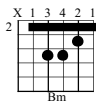
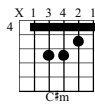
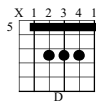
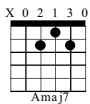

Second system of musical notation, including treble, guitar, and bass staves.

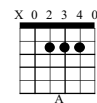
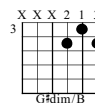
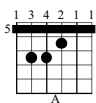
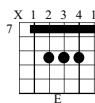
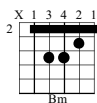
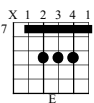

Third system of musical notation, including treble, guitar, and bass staves.

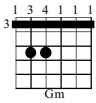
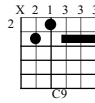
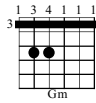
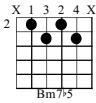
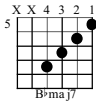
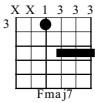

First system of musical notation, including treble, guitar, and bass staves.

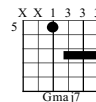
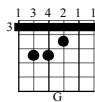
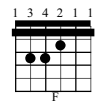
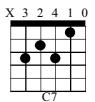
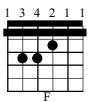
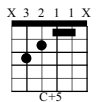
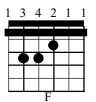

Second system of musical notation, including treble, guitar, and bass staves.

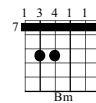
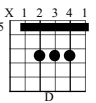
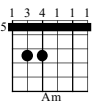
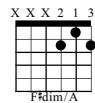
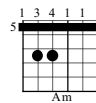
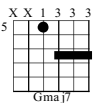
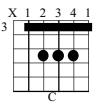

Third system of musical notation, including treble, guitar, and bass staves.

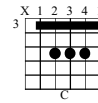
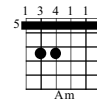
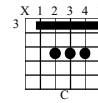
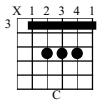
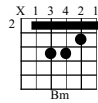
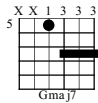
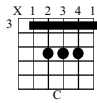

First system of musical notation, including treble, guitar, and bass staves.

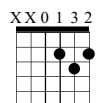
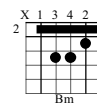
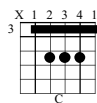
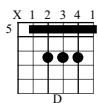
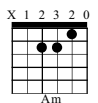
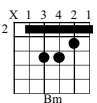
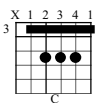
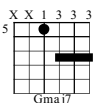

Second system of musical notation, including treble, guitar, and bass staves.

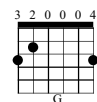
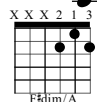
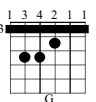
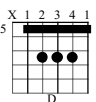
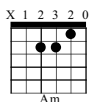
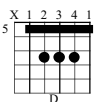

Third system of musical notation, including treble, guitar, and bass staves.

RuneTuner

Composer: Paul William Engholm



♩ = 120

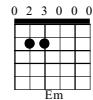
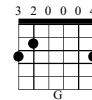
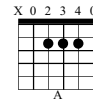
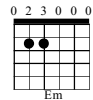
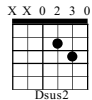
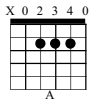

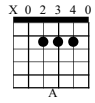
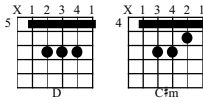
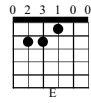
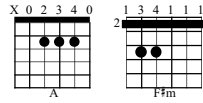
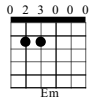
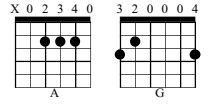
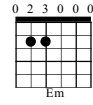
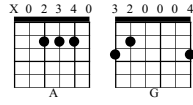
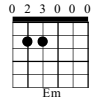
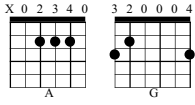

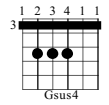
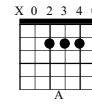
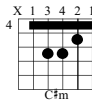
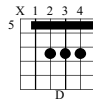
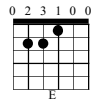
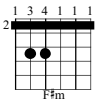
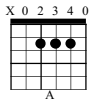

Musical notation for the first system, consisting of four staves. The first three staves are in treble clef with a key signature of one sharp (F#), and the fourth staff is in bass clef with the same key signature. The music features a melodic line in the first staff, a harmonic accompaniment in the second and third staves, and a bass line in the fourth staff. The system concludes with a double bar line.

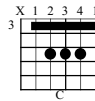
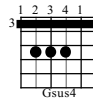
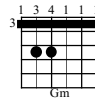
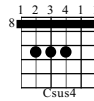
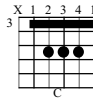

Musical notation for the second system, consisting of four staves. The first three staves are in treble clef with a key signature of one flat (Bb), and the fourth staff is in bass clef with the same key signature. The music features a melodic line in the first staff, a harmonic accompaniment in the second and third staves, and a bass line in the fourth staff. The system concludes with a double bar line.

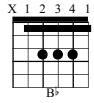
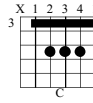
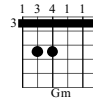
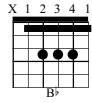
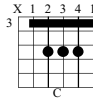
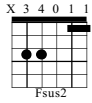

Musical score for the first system, consisting of four staves. The top two staves are treble clef, and the bottom two are bass clef. The music features a mix of eighth and quarter notes, with some triplets indicated by a '3' above the notes. The bass line provides a steady accompaniment.

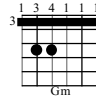
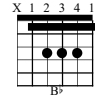
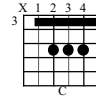
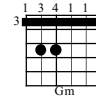
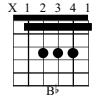
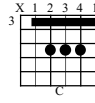
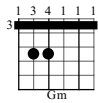

Musical score for the second system, consisting of four staves. The top two staves are treble clef, and the bottom two are bass clef. The music continues with similar rhythmic patterns and chord changes as the first system. A long note with a slur is present in the top staff.

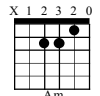

Musical notation for the first system, consisting of four staves (treble and bass clefs). The music is in a key with one flat (B-flat) and a 4/4 time signature. The notation includes various rhythmic patterns and chord changes corresponding to the diagrams above.

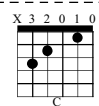
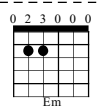
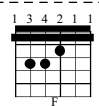
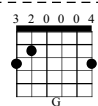

Musical notation for the second system, consisting of four staves. This system continues the piece and concludes with double bar lines and repeat dots. The notation includes various rhythmic patterns and chord changes corresponding to the diagrams above.

Star Emerald

Composer: Paul William Engholm

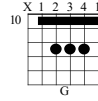
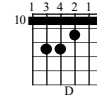
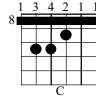
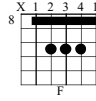
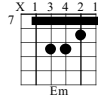
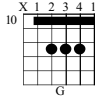

♩ = 120

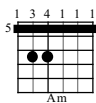
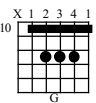
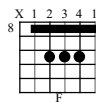
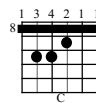
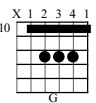
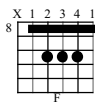
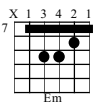

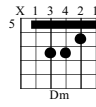
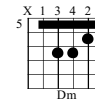
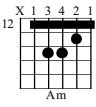
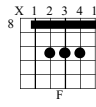
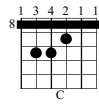
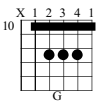
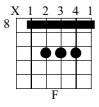

Da Φ

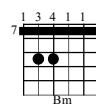
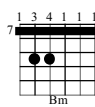
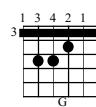
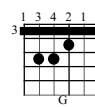
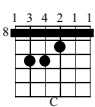
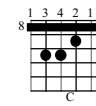
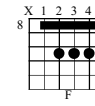
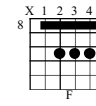
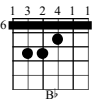
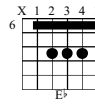
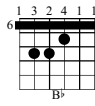

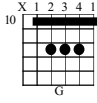
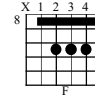
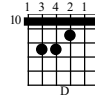
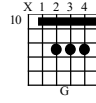
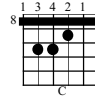
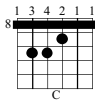

Da Capo Al Coda ⊕ ⊕

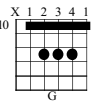
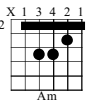
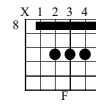
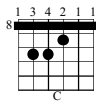
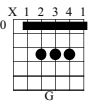
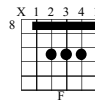
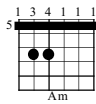

StrollAway

Composer: Paul William Engholm

X 3 2 0 1 0 3 2 0 0 0 4 X X 0 2 3 1 1 3 4 2 1 1 X 3 2 0 1 0 3 2 0 0 0 4 1 3 4 2 1 1 X X 0 2 3 1

C G Dm F C G F Dm

♩ = 160

3 2 0 0 0 4 X 3 2 0 1 0 X 3 2 0 1 0 X 3 2 0 1 0 3 2 0 0 0 4 1 3 4 2 1 1 1 3 4 2 1 1 X 3 2 0 1 0

G C C C G F F C

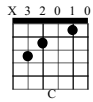
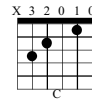
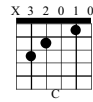
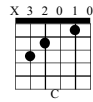
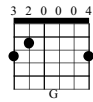
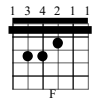
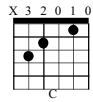

First system of musical notation, featuring four staves (Treble, Bass, Treble, Bass) with a melody line, a bass line, and two accompaniment lines. The notation includes various note values, rests, and dynamic markings.

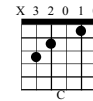
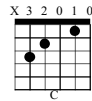
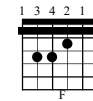
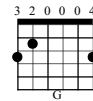
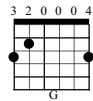
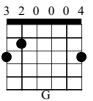
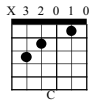

Second system of musical notation, featuring four staves (Treble, Bass, Treble, Bass) with a melody line, a bass line, and two accompaniment lines. The notation includes various note values, rests, and dynamic markings.

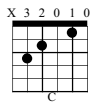
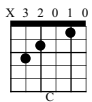
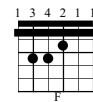
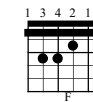
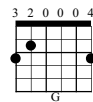
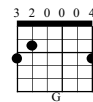
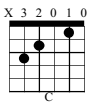

Third system of musical notation, featuring four staves (Treble, Bass, Treble, Bass) with a melody line, a bass line, and two accompaniment lines. The notation includes various note values, rests, and dynamic markings, ending with a double bar line and repeat dots.

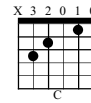
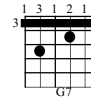
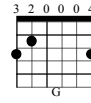
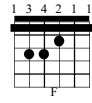
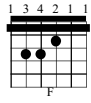
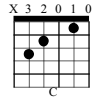
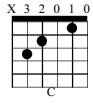

Musical notation for the first system, including treble and bass staves with chords.

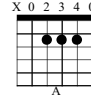
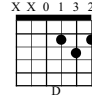
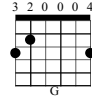
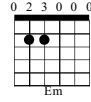
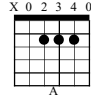
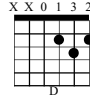
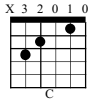

Musical notation for the second system, including treble and bass staves with chords.

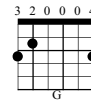
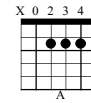
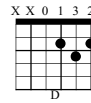
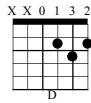
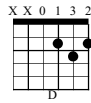
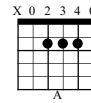
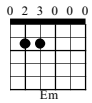
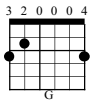

Musical notation for the third system, including treble and bass staves with chords.

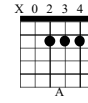
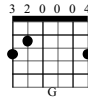
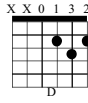
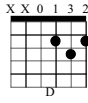
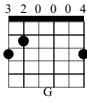

First system of musical notation. It consists of four staves: a treble staff with a melody line, a second treble staff with a vocal line, a guitar accompaniment staff with chords, and a bass staff with a bass line. The key signature has two sharps (F# and C#).

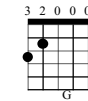
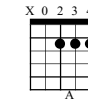
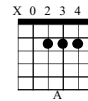
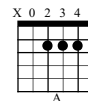
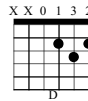
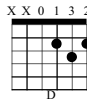
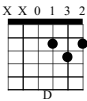

Second system of musical notation. It consists of four staves: a treble staff with a melody line, a second treble staff with a vocal line, a guitar accompaniment staff with chords, and a bass staff with a bass line. The key signature has two sharps (F# and C#).

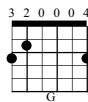
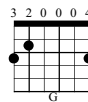
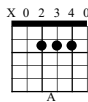
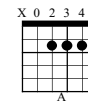
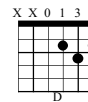
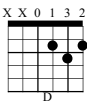
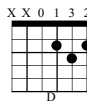

Third system of musical notation. It consists of four staves: a treble staff with a melody line, a second treble staff with a vocal line, a guitar accompaniment staff with chords, and a bass staff with a bass line. The key signature has two sharps (F# and C#).

XX0132



D

XX0132



D

XX0132



D

XX0132



D

320004



G

320004



G

X02340



A

The first system of the musical score consists of four staves. The top two staves are in treble clef with a key signature of one sharp (F#). The bottom two staves are in bass clef with a key signature of one sharp (F#). The music features a melodic line in the treble and a bass line in the bass. Above the first two staves, there are seven guitar chord diagrams corresponding to the notes in the treble staff. The first four diagrams are for D major (XX0132), and the last three are for G major (320004) and A major (X02340). The score includes a repeat sign and a double bar line.

X02030



A7

XX0132



D

XX0132



D

The second system of the musical score consists of four staves. The top two staves are in treble clef with a key signature of one sharp (F#). The bottom two staves are in bass clef with a key signature of one sharp (F#). The music continues from the first system, featuring a melodic line in the treble and a bass line in the bass. Above the first two staves, there are three guitar chord diagrams corresponding to the notes in the treble staff. The first diagram is for A7 (X02030), and the last two are for D major (XX0132). The score ends with a double bar line.

TwiliTime

Composer: Paul William Engholm

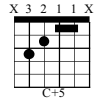
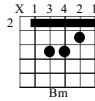
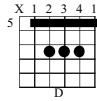
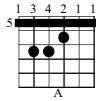
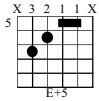

$\text{♩} = 120$

The first system of the musical score consists of four staves. The top staff is in treble clef with a key signature of two sharps (F# and C#) and a 3/4 time signature. It begins with a whole rest followed by a repeat sign and a melodic line of eighth and quarter notes. The second staff is also in treble clef and contains a more active melodic line. The third staff is in treble clef and features a bass line with chords and moving eighth notes. The fourth staff is in bass clef and contains a steady eighth-note bass line. A double bar line with repeat dots is placed after the first measure of each staff.

8vb-----

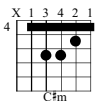
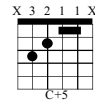
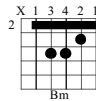
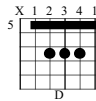
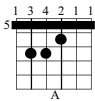

The second system of the musical score continues the four-staff arrangement. The top staff has a melodic line with some rests. The second staff continues the melodic development. The third staff shows chordal accompaniment with moving eighth notes. The fourth staff maintains the eighth-note bass line. A double bar line with repeat dots is placed after the first measure of each staff.

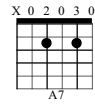
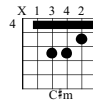
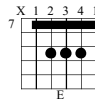
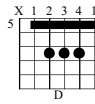
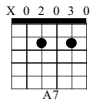

Musical notation for the first system, consisting of four staves (treble and bass clefs) in the key of A major. The notation includes a melody line, a guitar accompaniment line, and two bass lines. The first staff contains a melody with a dotted quarter note and an eighth note. The second staff contains a guitar accompaniment with eighth notes. The third staff contains a bass line with chords and eighth notes. The fourth staff contains a bass line with eighth notes.

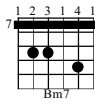
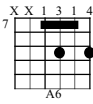
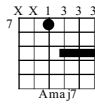
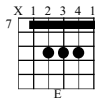
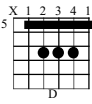

Musical notation for the second system, consisting of four staves (treble and bass clefs) in the key of A major. The notation includes a melody line, a guitar accompaniment line, and two bass lines. The first staff contains a melody with a repeat sign. The second staff contains a guitar accompaniment with eighth notes. The third staff contains a bass line with chords and eighth notes. The fourth staff contains a bass line with eighth notes.

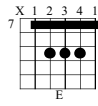
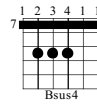
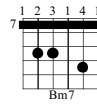
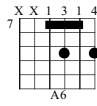
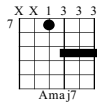
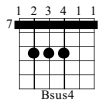

Musical notation for the first system, including treble and bass staves with a guitar accompaniment staff.

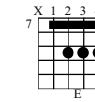
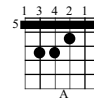
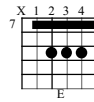
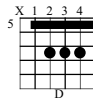
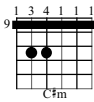
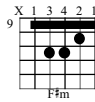
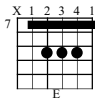
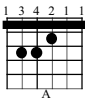

Musical notation for the second system, including treble and bass staves with a guitar accompaniment staff.

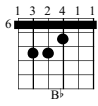
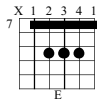
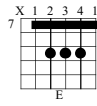
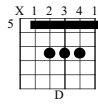
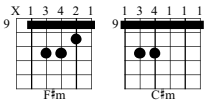

Da Φ *Dal Segno* S *Al Coda* Φ Φ

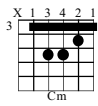
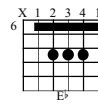
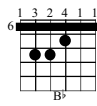
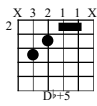
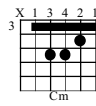
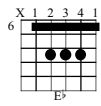

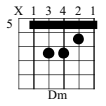
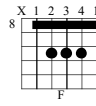
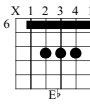
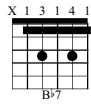
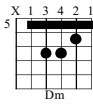
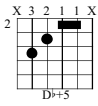

Musical notation for the first system, consisting of four staves (treble and bass clefs) in a 4/4 time signature. The key signature has one flat (Bb). The notation includes various note values, rests, and accidentals.

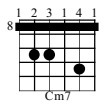
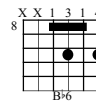
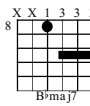
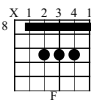
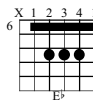
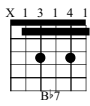

Musical notation for the second system, consisting of four staves (treble and bass clefs) in a 4/4 time signature. The key signature has one flat (Bb). The notation includes various note values, rests, and accidentals, with repeat signs indicating a second ending.

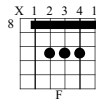
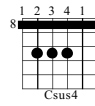
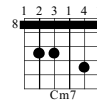
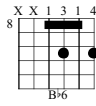
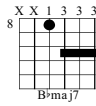
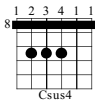

Musical notation for the first system, including treble and bass staves with a guitar accompaniment staff.

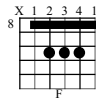
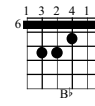
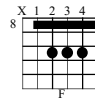
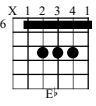
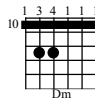
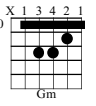
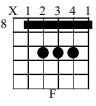
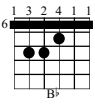
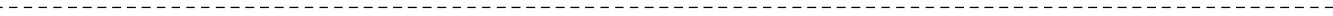

Musical notation for the second system, including treble and bass staves with a guitar accompaniment staff.



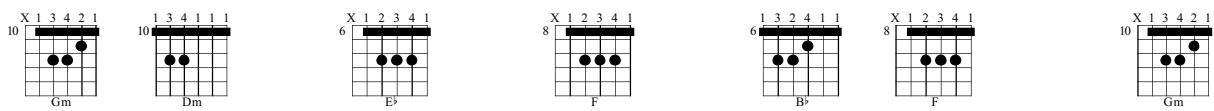

Musical notation for the first system, including treble and bass staves with notes and chords.



Musical notation for the second system, including treble and bass staves with notes and chords.

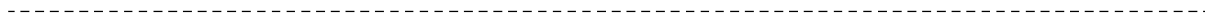
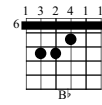
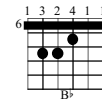
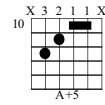
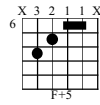
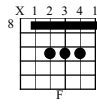
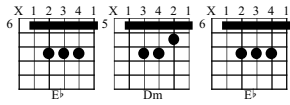

White Crow Waltz

Composer: Paul William Engholm

♩ = 120

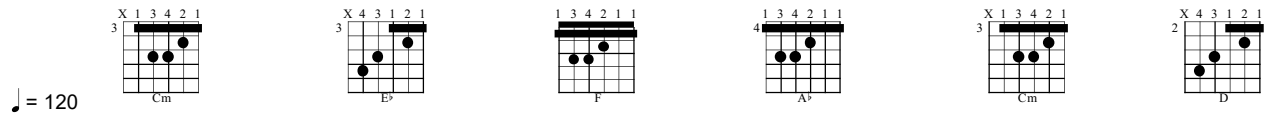

♩ = 75

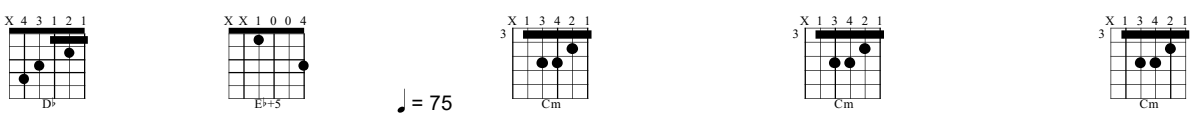

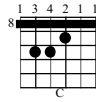
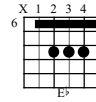
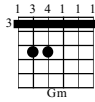
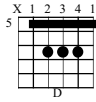

First system of musical notation, including treble, guitar, and bass staves.

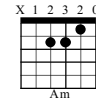
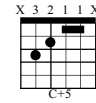
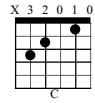
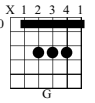
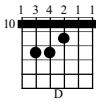
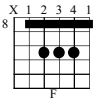

Second system of musical notation, including treble, guitar, and bass staves.

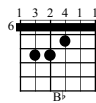
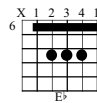
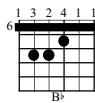
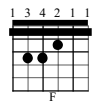
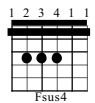
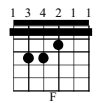
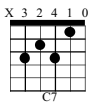

Third system of musical notation, including treble, guitar, and bass staves.

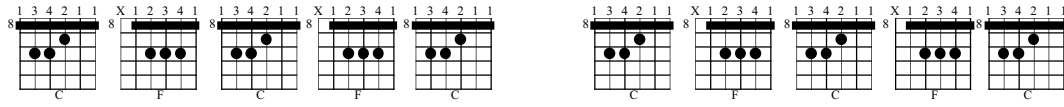

Guitar Chord Diagrams

Guitar Chord Diagrams

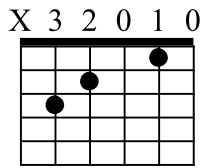

C

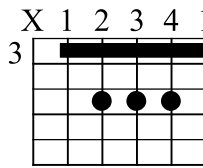

C

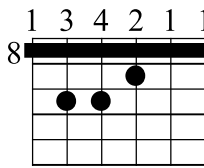

C

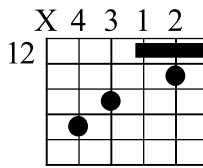

C

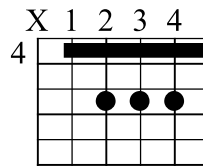

C#

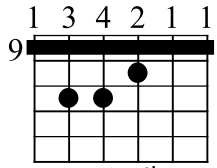

C#

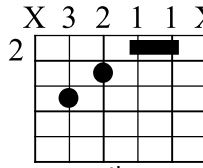

C#+5

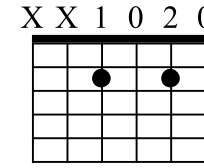

C#dim/E

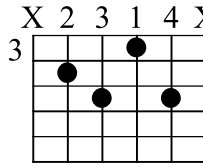

C#dim7

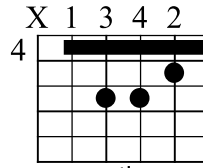

C#m

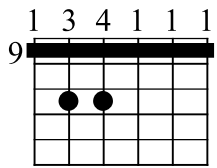

C#m

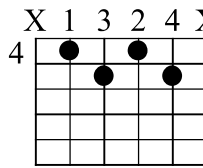

C#m7^b5

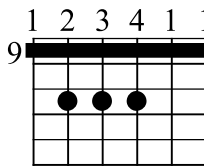

C#sus4

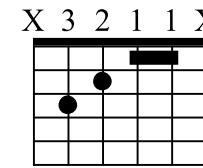

C+5

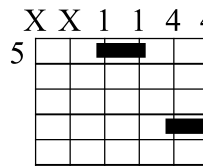

C5

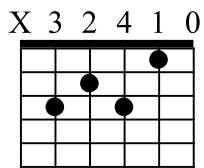

C7

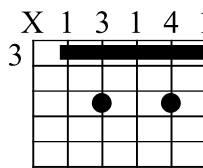

C7

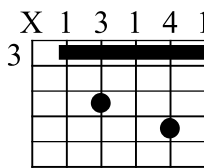

C7sus4

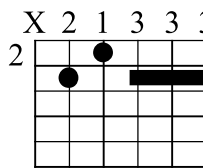

C9

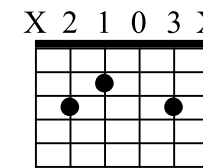

Cadd9

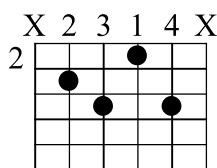

Cdim7

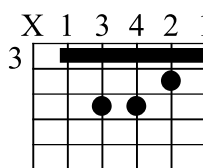

Cm

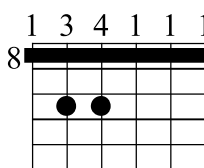

Cm

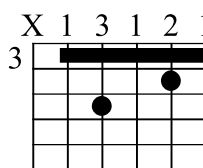

Cm7

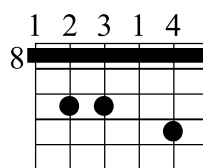

Cm7

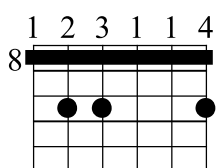

Cm9

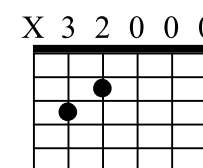

Cmaj7

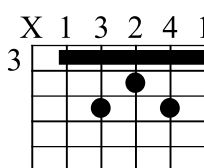

Cmaj7

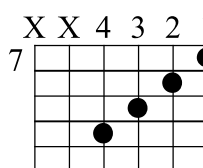

Cmaj7

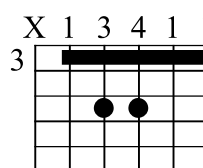

Csus2

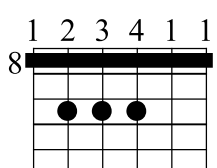

Csus4

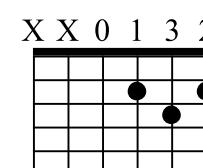

D

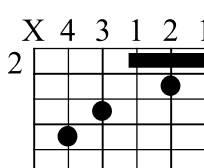

D

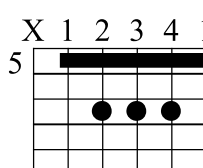

D

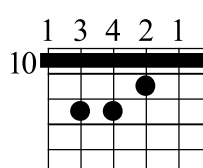

D

Guitar Chord Diagrams

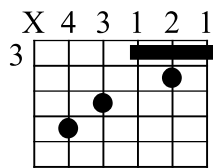

D#

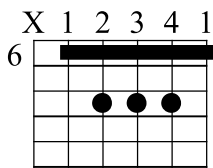

D#

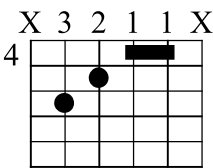

D#+5

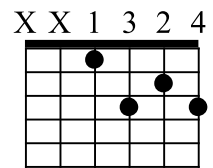

D#7

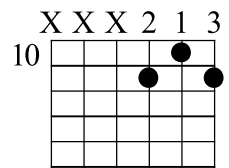

D#dim/F#

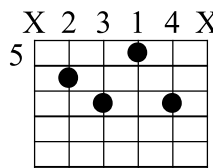

D#dim7

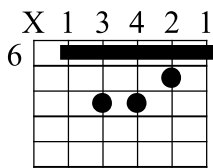

D#m

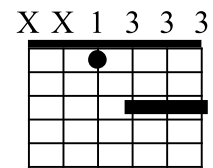

D#maj7

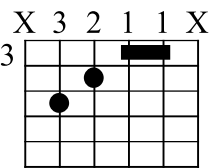

D+5

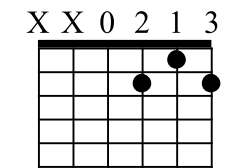

D7

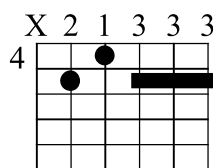

D9

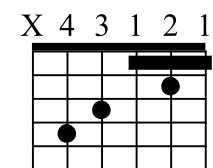

Db

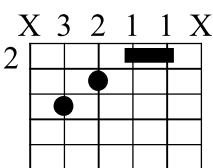

Db+5

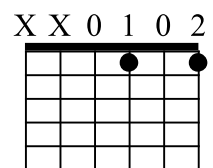

Ddim7

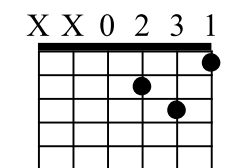

Dm

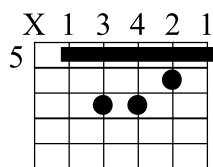

Dm

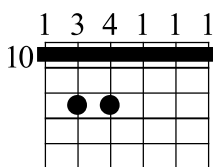

Dm

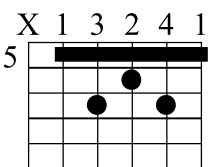

Dmaj7

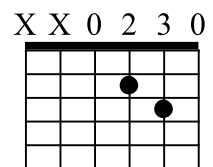

Dsus2

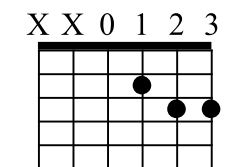

Dsus4

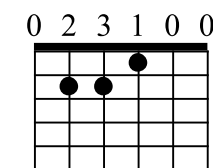

E

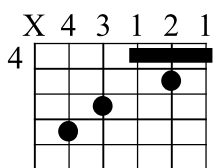

E

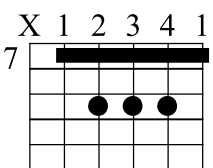

E

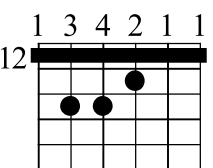

E

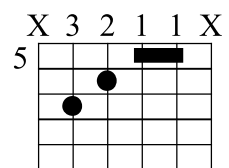

E+5

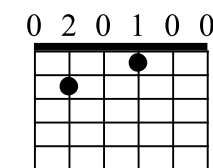

E7

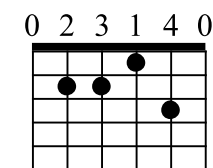

E7

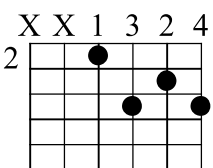

E7

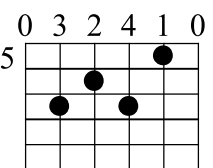

E7

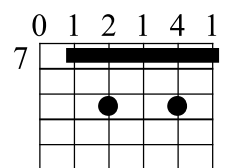

E7

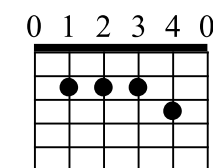

E7sus4

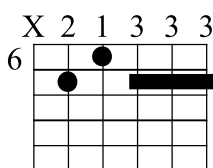

E9

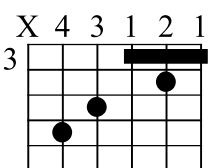

Eb

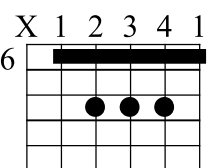

Eb

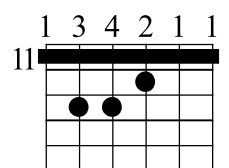

Eb

Guitar Chord Diagrams

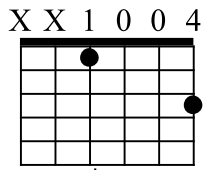

Eb+5

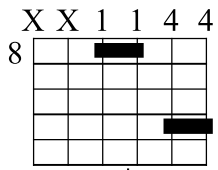

Eb5

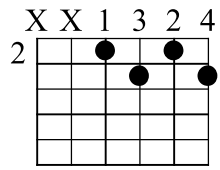

Edim7

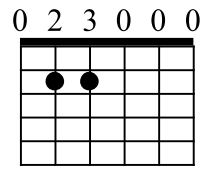

Em

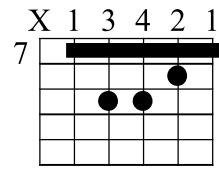

Em

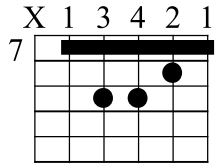

Em

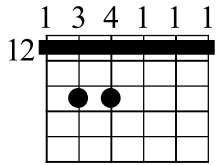

Em

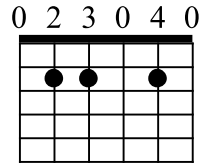

Em6

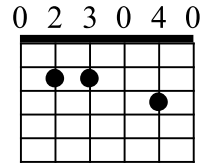

Em7

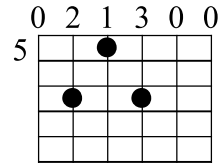

Em7

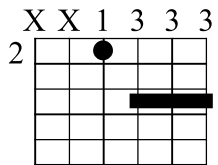

Ema j7

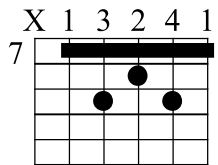

Ema j7

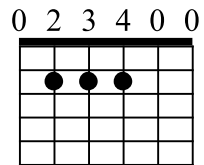

Esus4

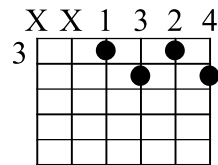

Fdim7

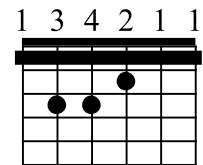

F

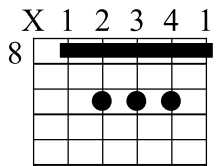

F

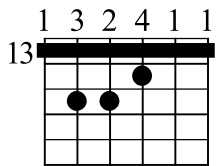

F

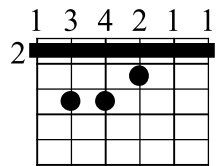

F#

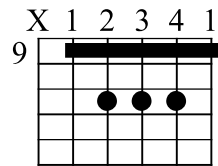

F#

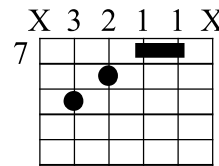

F#+5

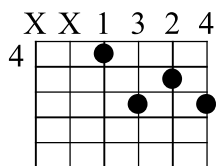

F#7

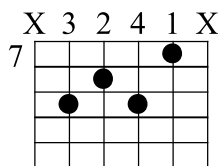

F#7

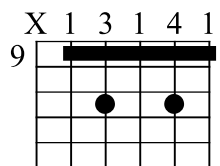

F#7

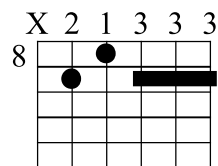

F#9

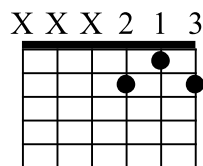

F#dim/A

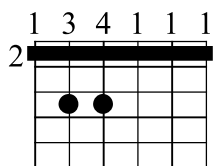

F#m

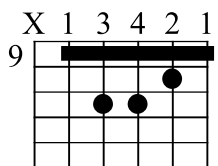

F#m

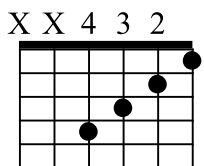

F#maj7

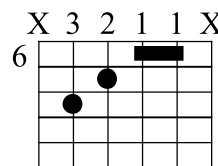

F+5

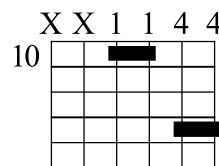

F5

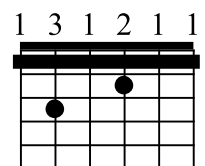

F7

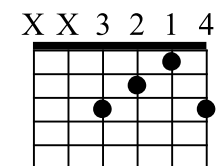

Fadd9

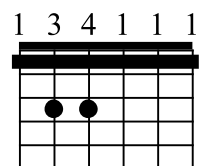

Fm

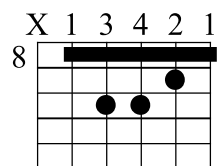

Fm

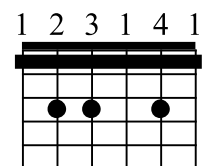

Fm6

Guitar Chord Diagrams

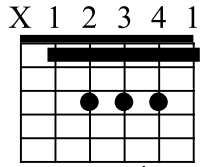

A#

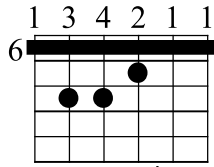

A#

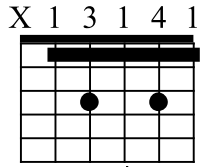

A#7

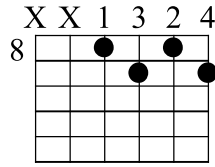

A#dim7

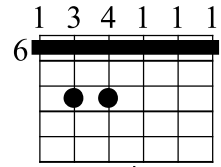

A#m

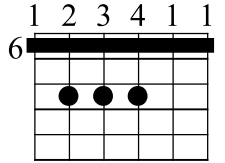

A#sus4

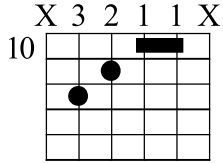

A+5

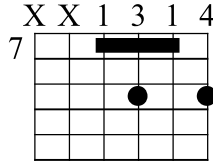

A6

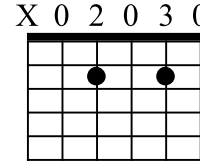

A7

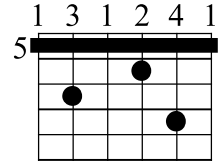

A7

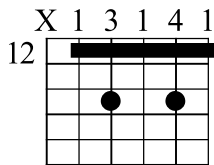

A7

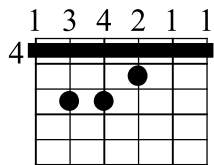

A \flat

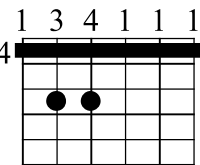

A \flat m

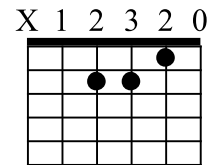

Am

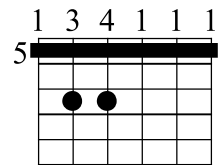

Am

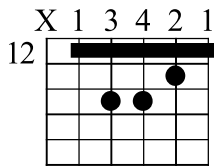

Am

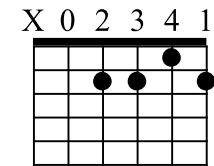

Am6

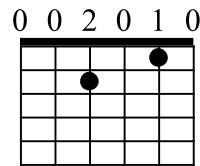

Am7

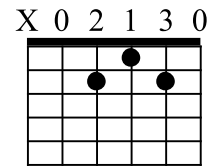

Amaj7

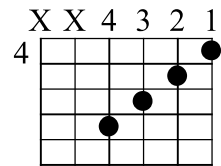

Amaj7

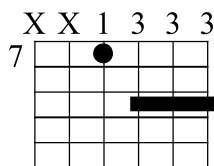

Amaj7

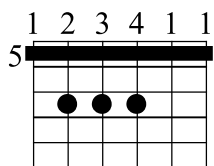

Asus4

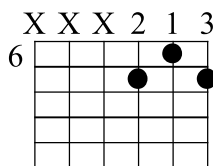

Bdim/D

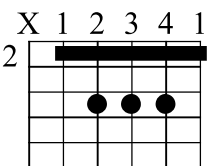

B

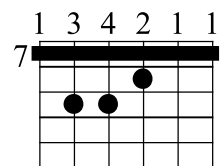

B

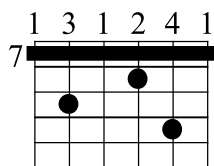

B7

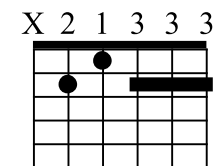

B9

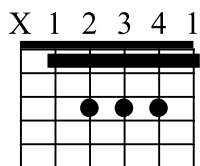

B \flat

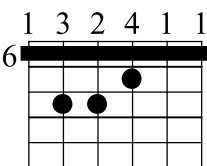

B \flat

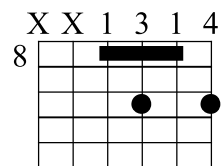

B \flat 6

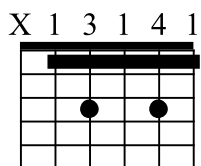

B \flat 7

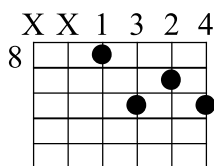

B \flat 7

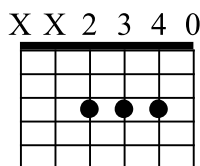

B $\flat\flat$ 5/F

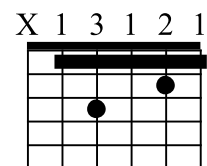

B \flat m7

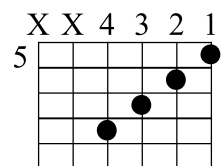

B \flat maj7

Guitar Chord Diagrams

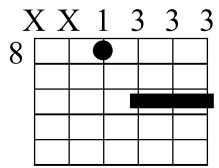

B^bmaj7

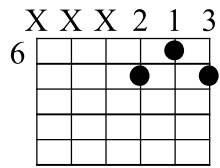

Bdim/D

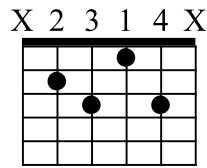

Bdim7

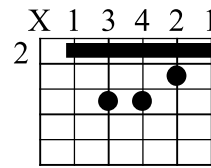

Bm

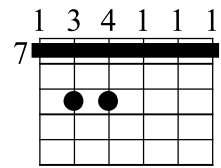

Bm

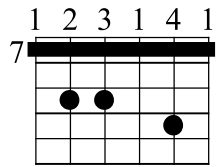

Bm7

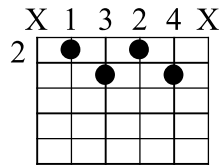

Bm7^b5

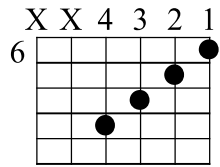

Bmaj7

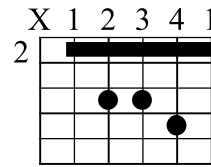

Bsus4

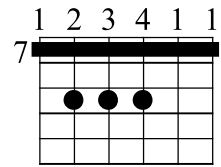

Bsus4

DIY AUDIO EFX 'Unique' Musical/Audio Electronics Projects

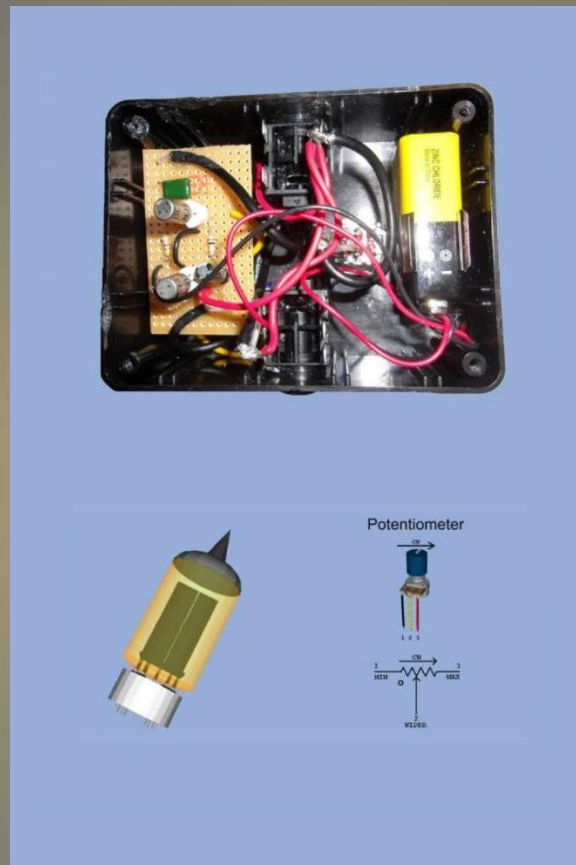

by
Paul William Engholm

DIY AUDIO EFX 'Unique' Musical/Audio Electronics Projects

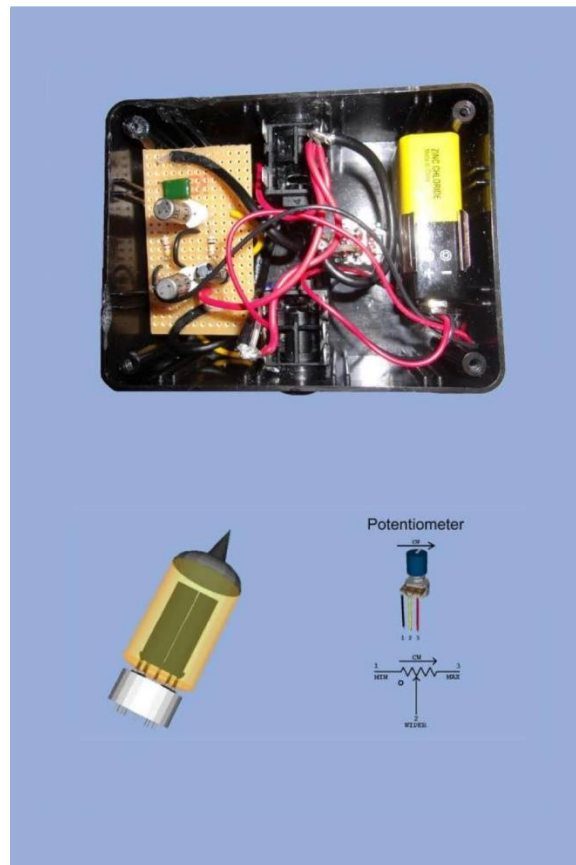

by
Paul William Engholm

Table of Contents

Audio Projects:
True Bypass EFX
Send/Receive EFX
Low Impedance Preamp
Transistor Bass and Treble Tone Controls
LM1458 Dual OpAmp 3 Tone Controls
6 Band Equalizer
4 Channel Audio Mixer
4 Channel Audio Mixer 2
Audio Overdub Mixer
Audio Overdub Mixer 1
Audio Overdub Mixer 2
Audio Overdub Mixer 3
4-Input 2-Output Audio Mixer
AAA FUZZ (2 Versions)
Vintage Guitar Fuzz (3 Versions)
Overdrive/Distortion Preamp
Electric Guitar Distortion Effect
Z-Overdrive
NPN Transistors Fuzz Effect
LM741-LM386 Overdrive/Distortion Effect
LM741-LM386 Overdrive/Fuzz Effect
LM741/Transistors Octave Fuzz Effect
LM386/Transformer Octave Fuzz Effect
Transistors/Transformer Octave Fuzz Effect
Transistors Octave Fuzz Effect
Octave SuperFuzz Effect
Big Muff 1Pi
Big Muff 2Pi
Plug-In Electric Guitar Fuzz Effect
OpAmp/12AX7A Tube Overdrive Effect
OpAmp/12AX7A Tube Overdrive Effect 2
Attack/Decay Effect
Voltage Controlled Bandpass Filter
AutoWah Effect
Wah Tone Effect
LM1496 Audio Frequency Doubler
AD633 Ring Modulator
LM386 Square Wave Oscillator (w/Speaker)
LM386 Square Wave Oscillator PCB
2 Transistor Sine Wave Audio Signal Generator
Audio Signal Injector
Signal Injector/Tracer
LM386 Low Voltage Audio Amplifier

DC Power Supply Projects:
5 VDC w/Backup Power
9 VDC Power Supply
Multi-Voltage Power Supply
Variable DC Power Supply (4 Versions)

Valve Projects:
5U4GB Power Supply
Tube Audio Amplifier 1
Tube Audio Amplifier 2
Tube Audio Amplifier 3
Tube Audio Amplifier 4
Tube Audio Amplifier 5
Tube Audio Amplifier 6
Tube Audio Amplifier 7
Tube Audio Amplifier 8
Tube Audio Amplifier 9
Tube Audio Amplifier 10

Experimental Projects:
ADSR Effect
CA3080 Voltage Controlled Amplifier
Envelope Follower 1
Envelope Follower 2
LED Audio Clip Detector
LED Peak Detector (4 Versions)
LM1458 1 Band Equalizer
Quad OpAmp Voltage Controlled Amplifier 1
Quad OpAmp Voltage Controlled Amplifier 2
LM741 OpAmp Audio Preamp
TL071 OpAmp Audio Preamp
LM1458 Dual OpAmp Audio Preamp
TL072 Dual OpAmp Audio Preamp
NSL-32 Optocoupler
Voltage Controlled Amplifier 1
Voltage Controlled Amplifier 2
Voltage Controlled Amplifier 3
Transistor ADSR
Transistor Audio Power Amp

... Supplemental ...

Audio Projects:

True Bypass EFX

True Bypass EFX

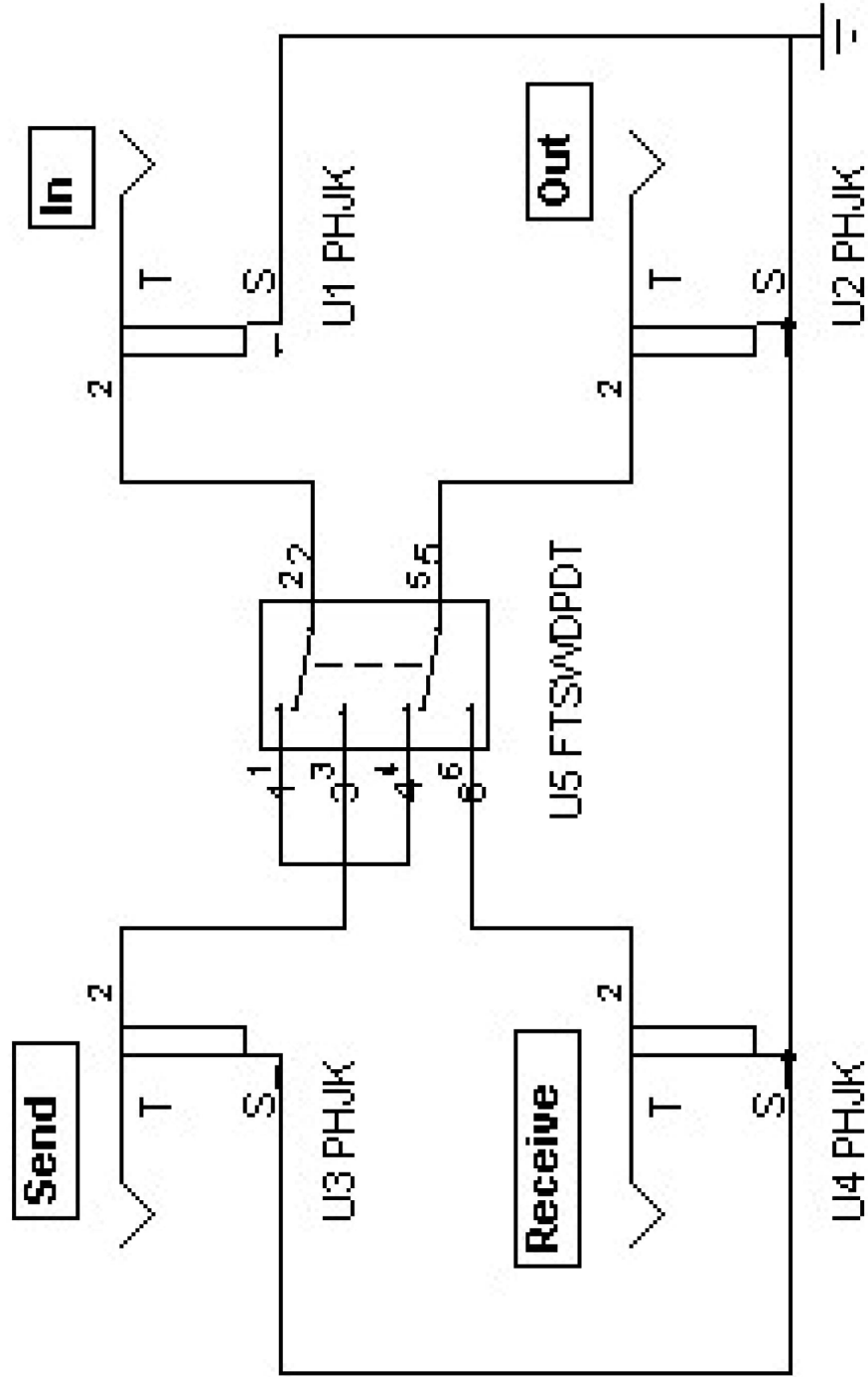

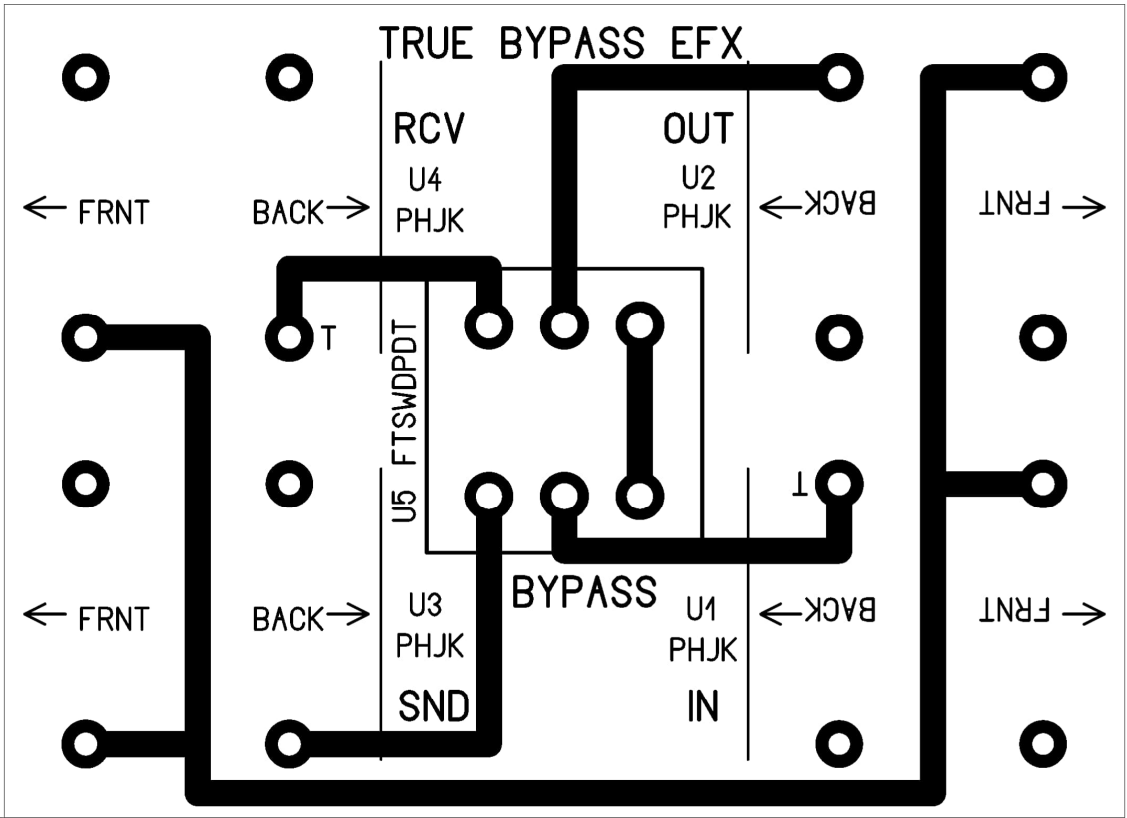

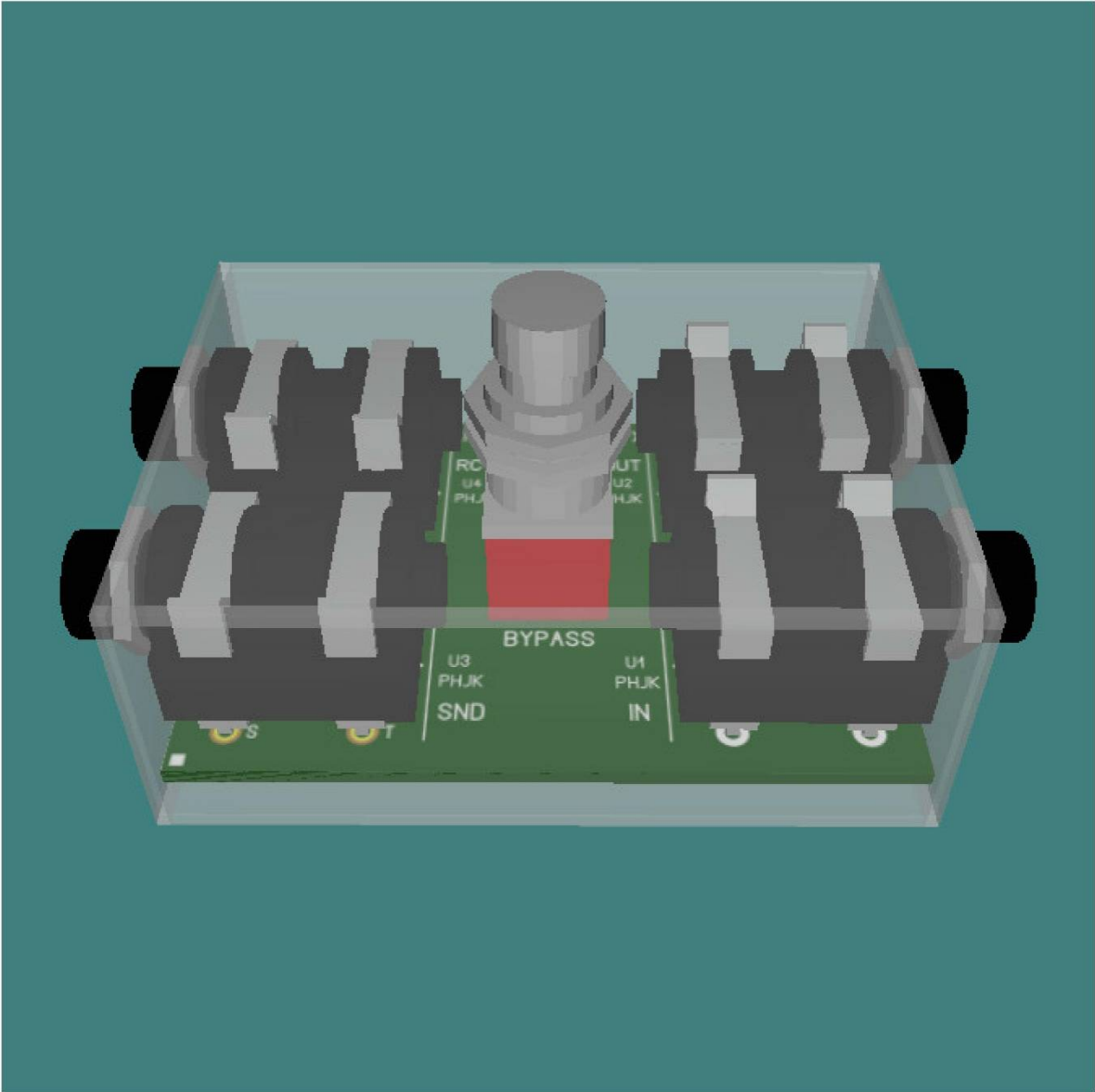

Send/Receive EFX

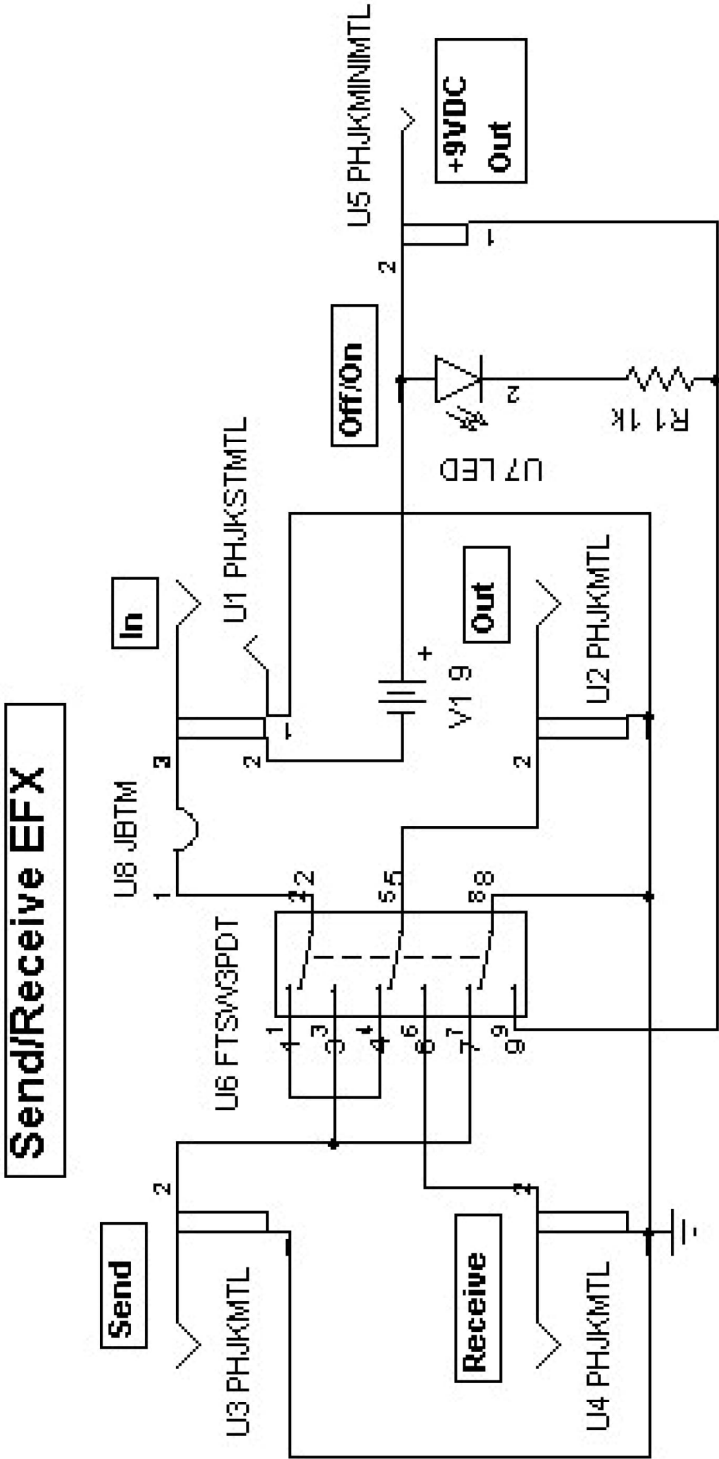

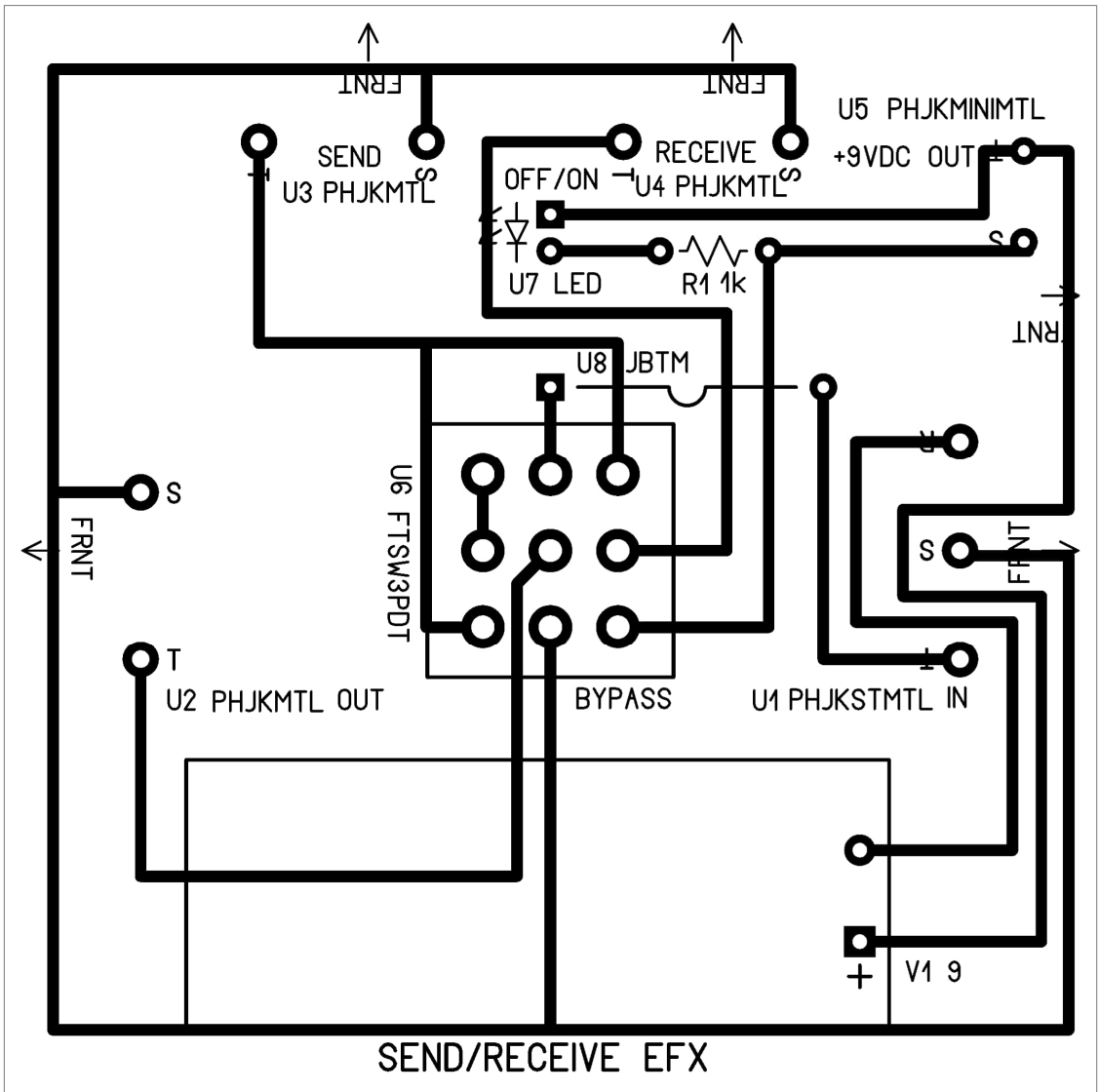

SEND/RECEIVE EFX

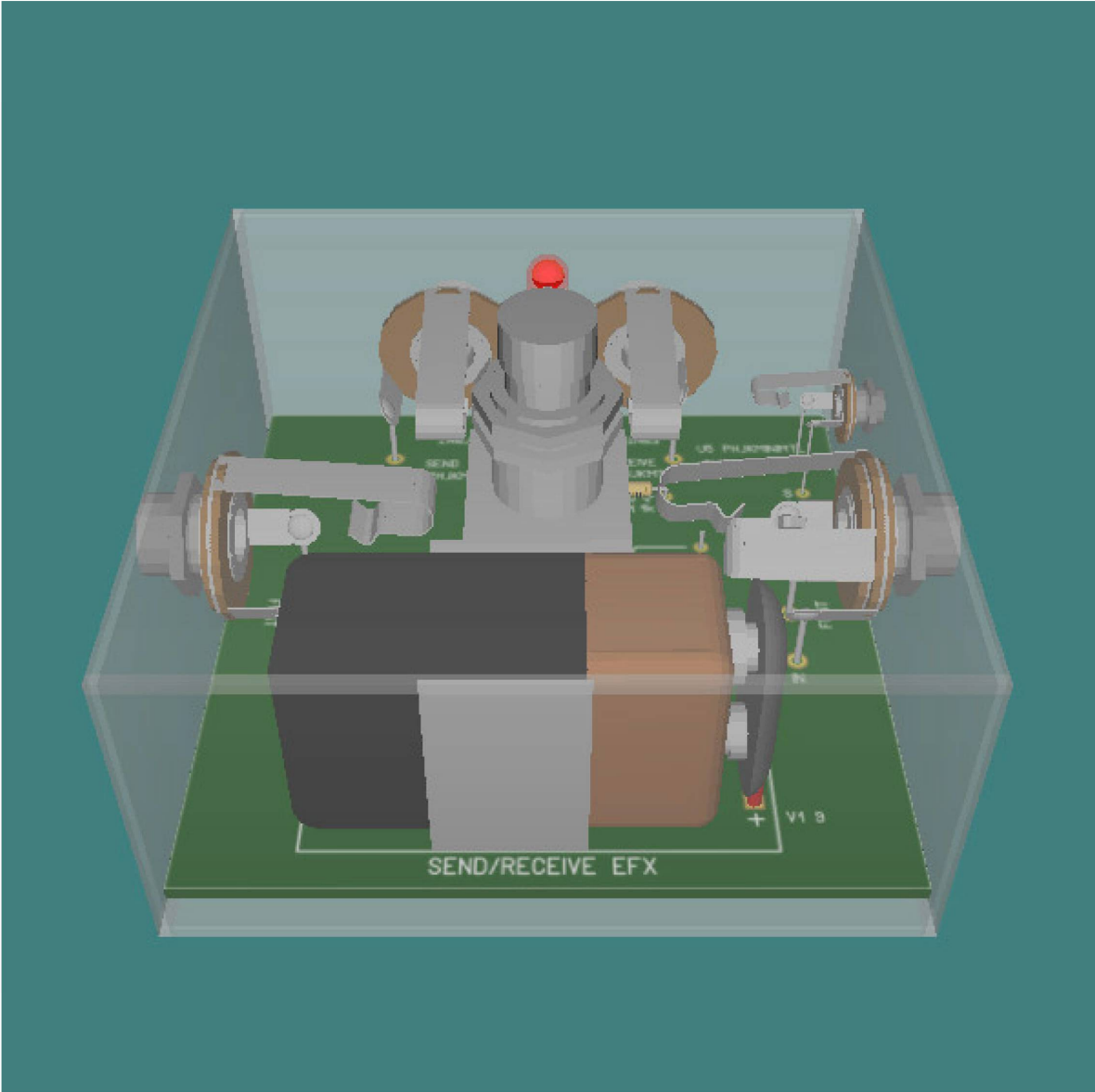

Low Impedance Preamp

Low Impedance Preamp Schematic

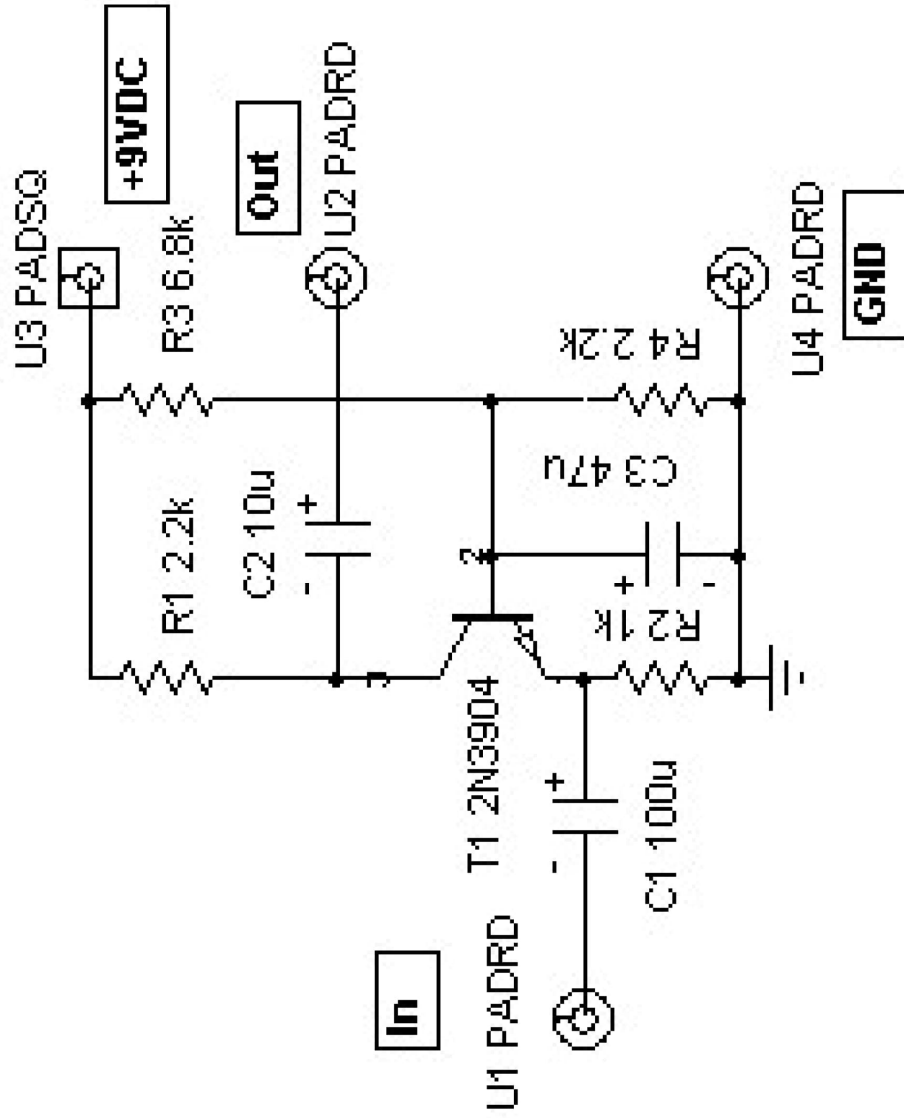

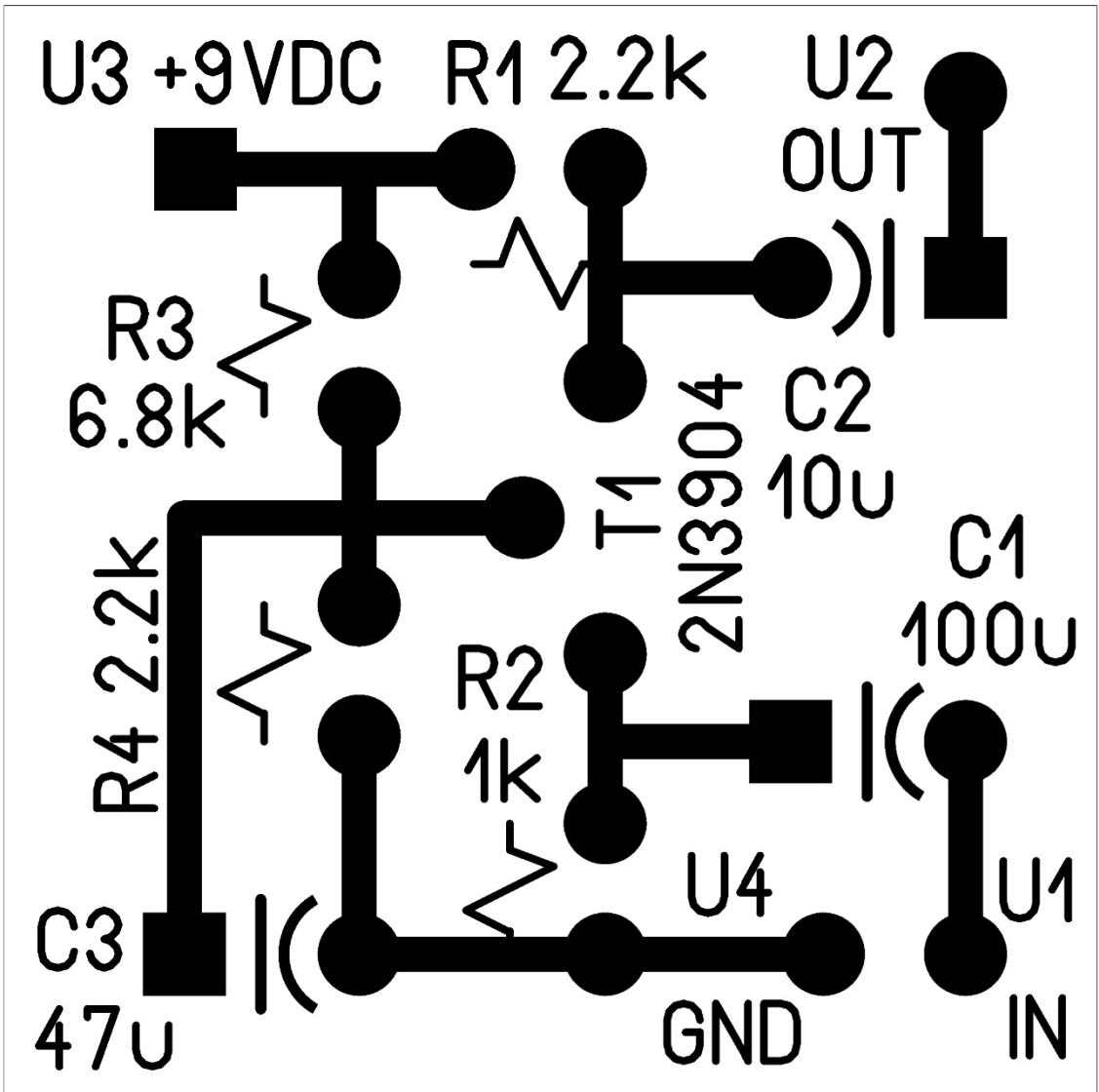

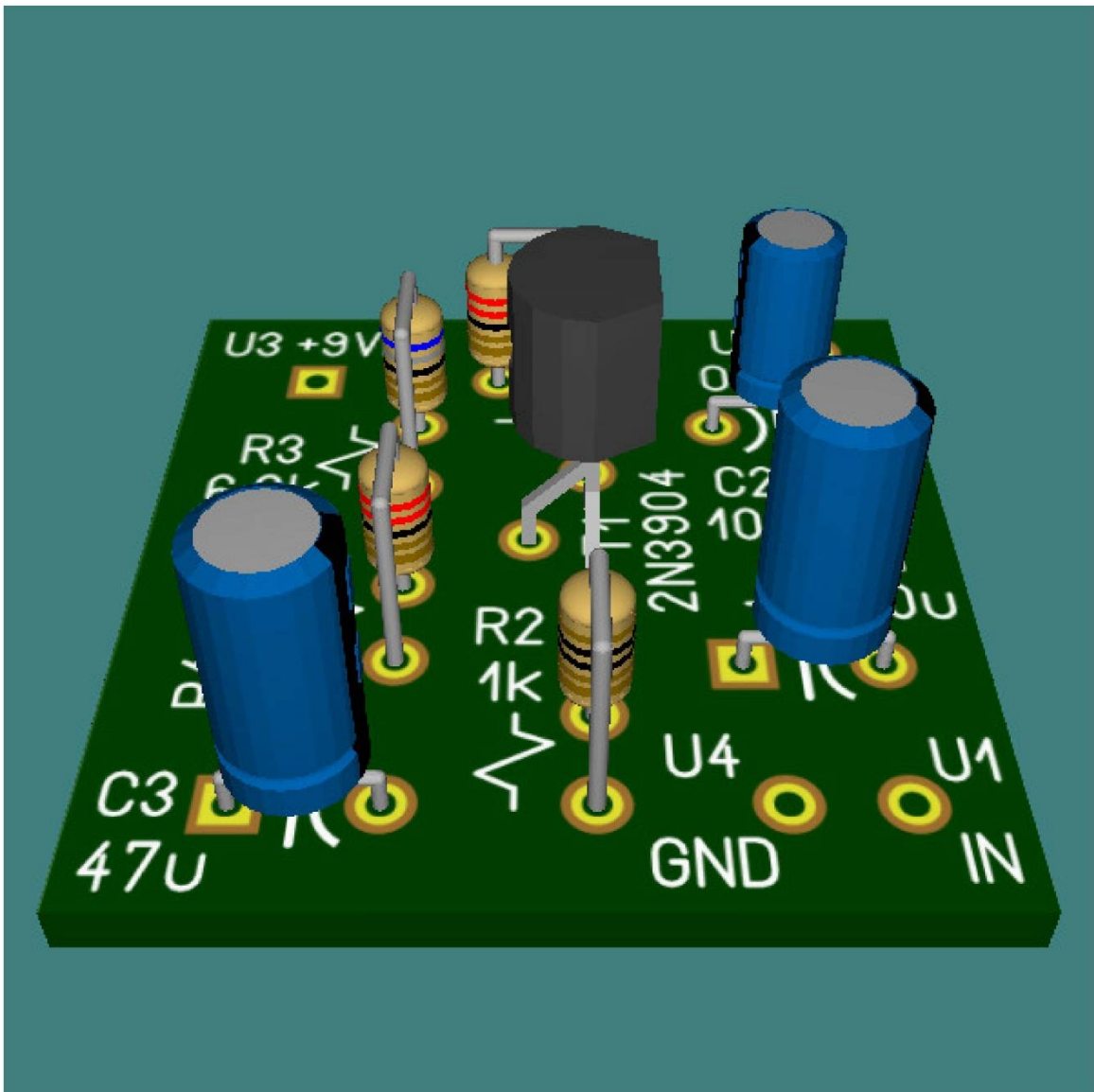

Transistor Bass and Treble Tone Controls

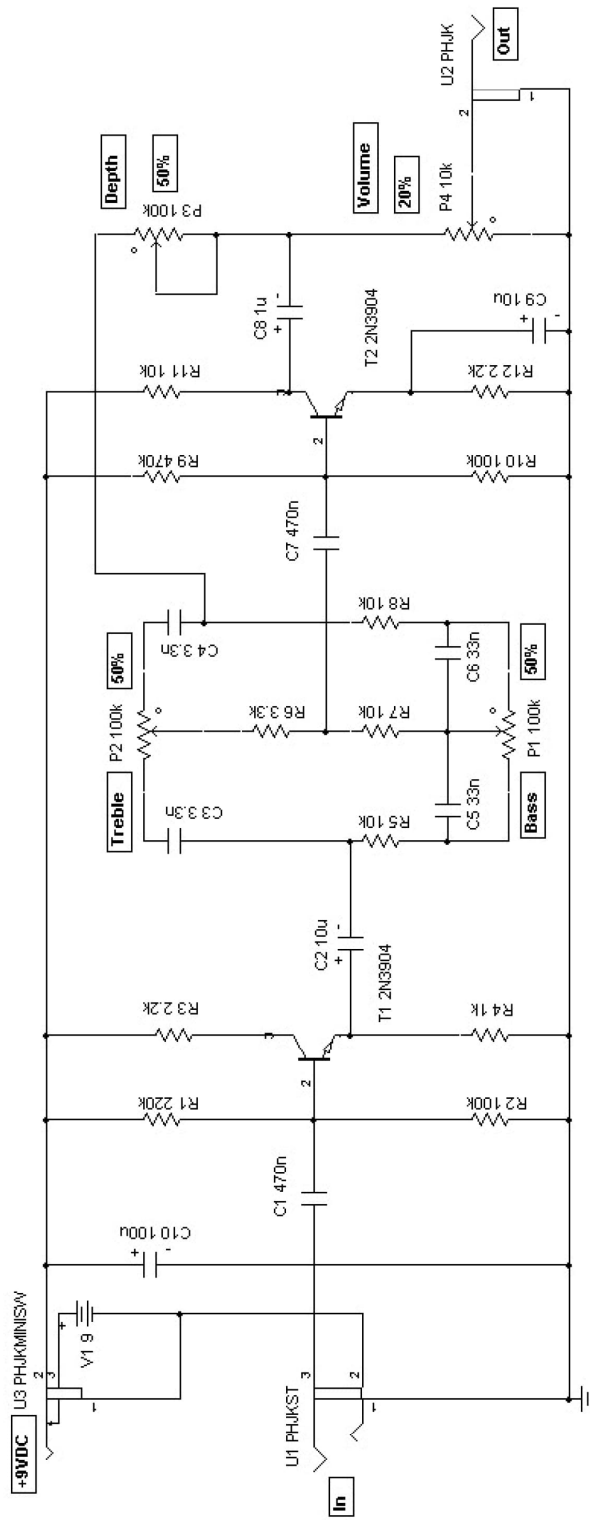

Transistor Bass and Treble Tone Controls Schematic

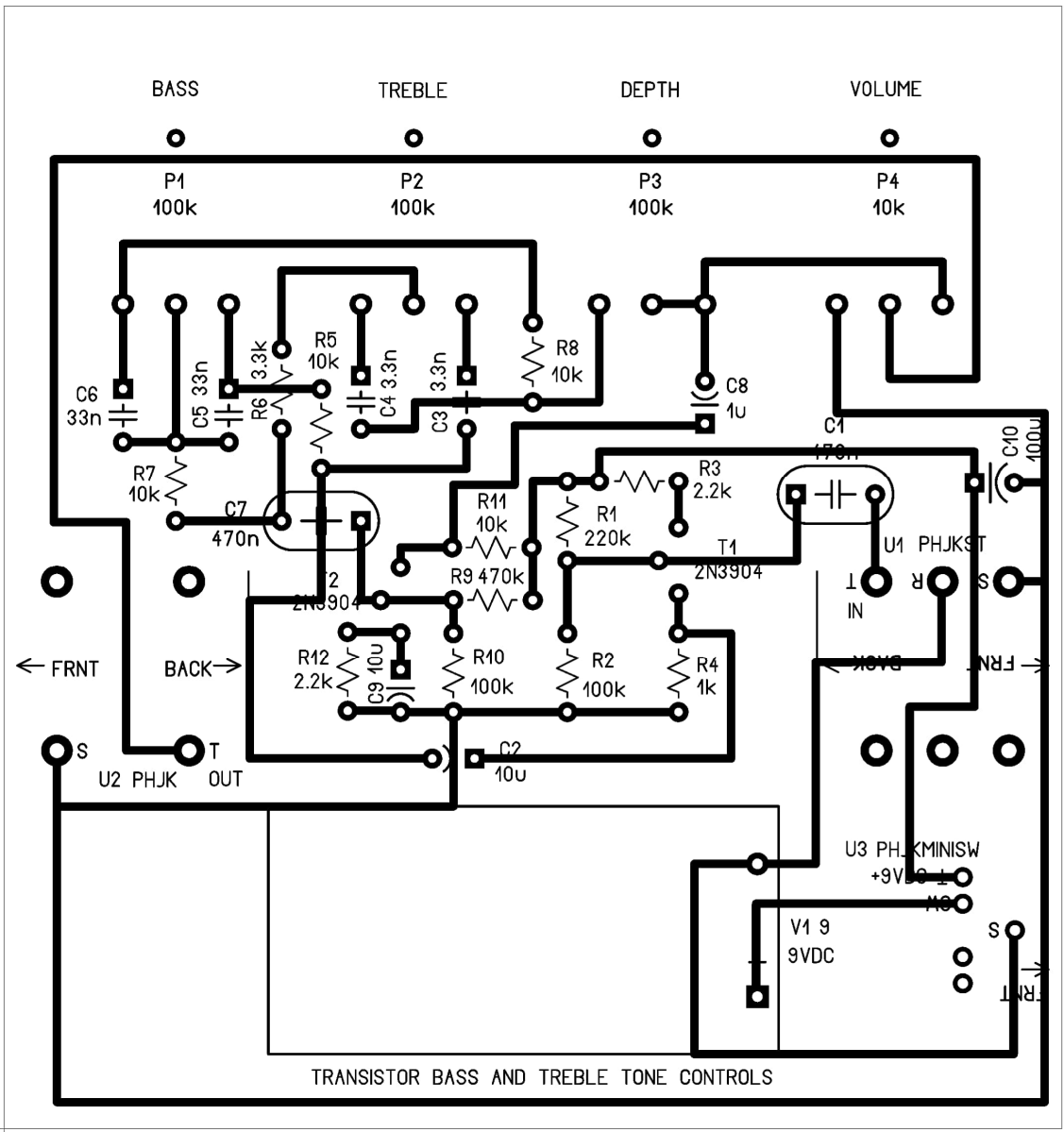

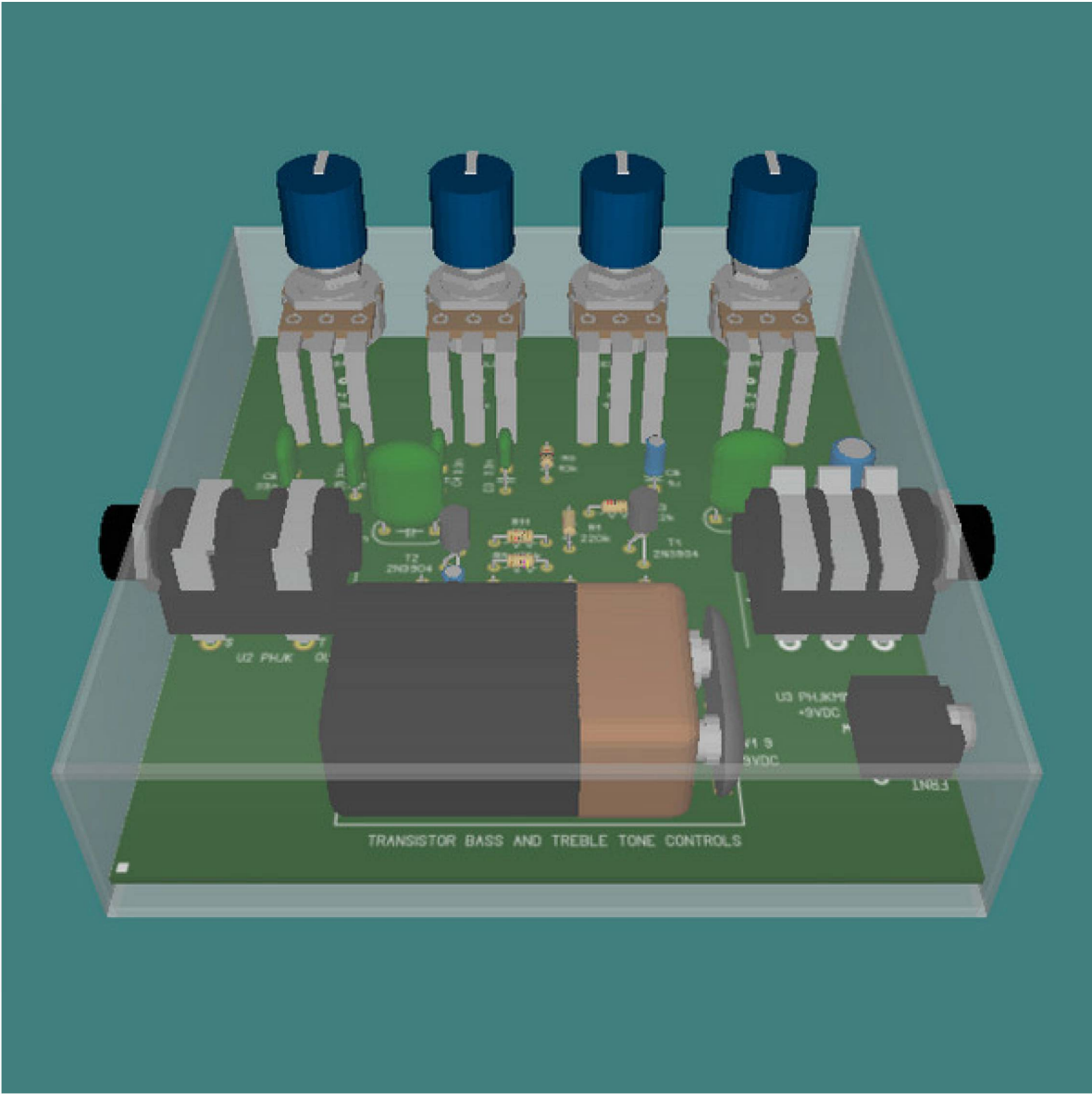

LM1458 Dual OpAmp 3 Tone Controls

LM1458 Dual OpAmp 3 Tone Controls Schematic

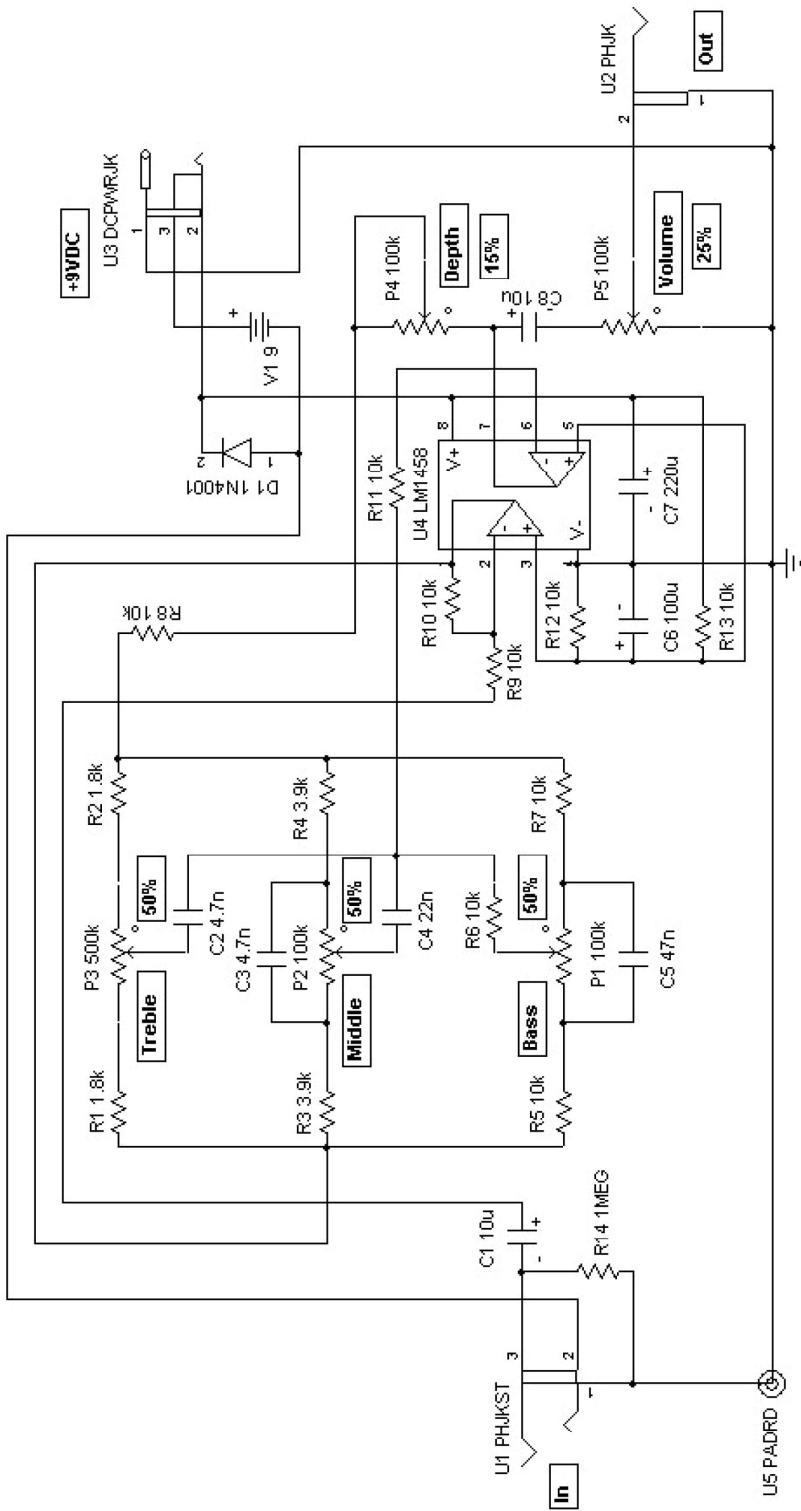

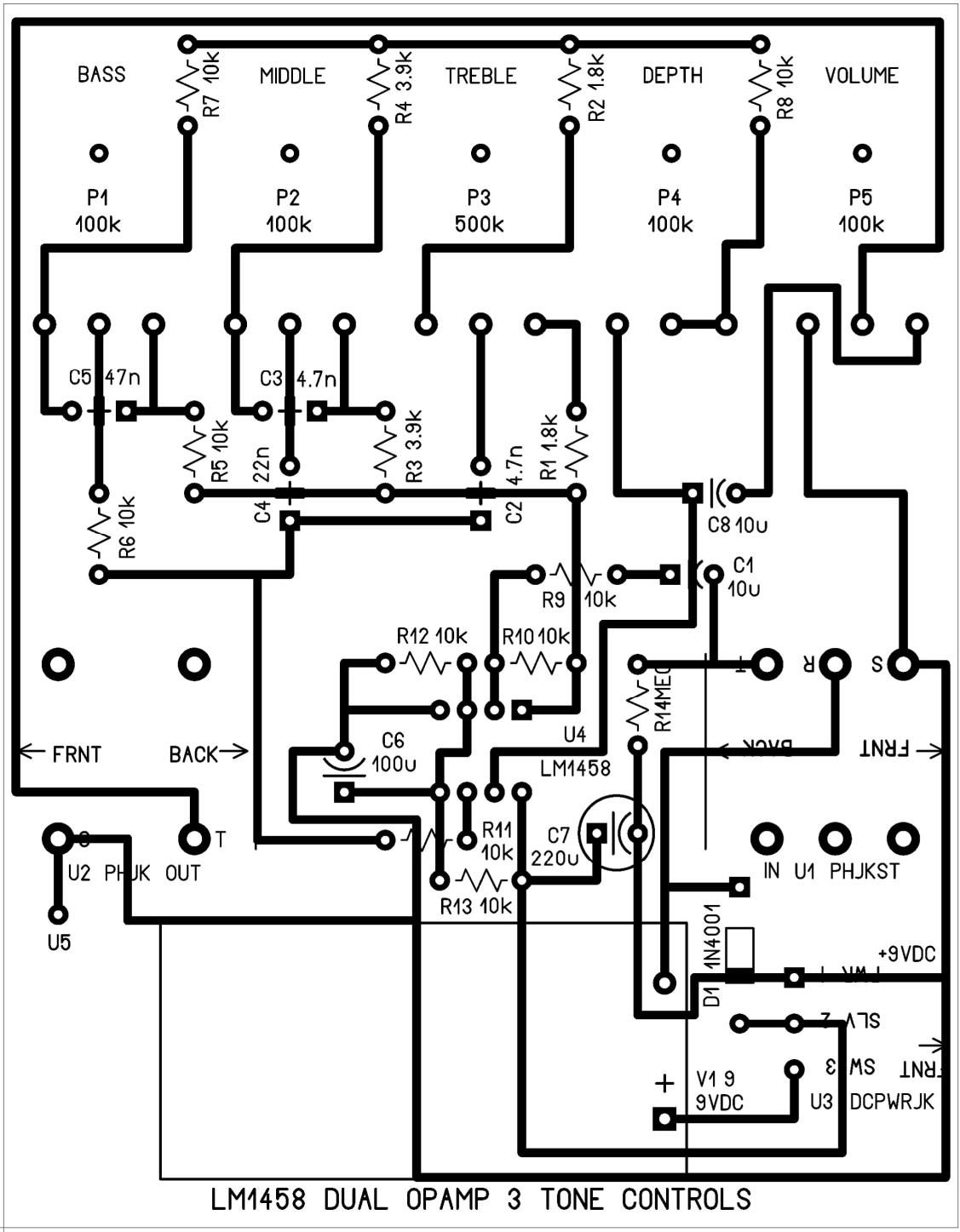

LM1458 DUAL OPAMP 3 TONE CONTROLS

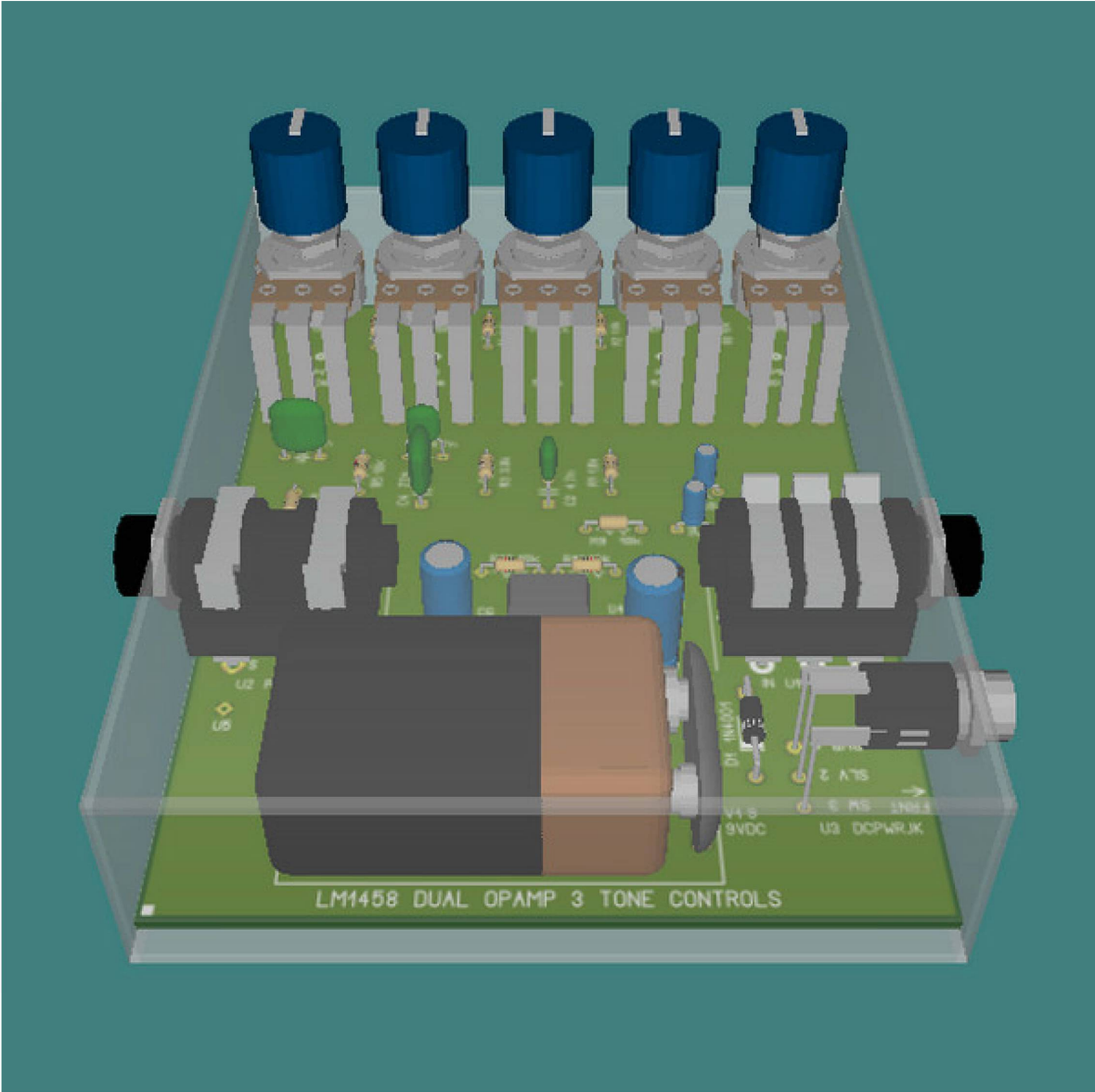

6 Band Equalizer

6 Band Graphic Equalizer Schematic

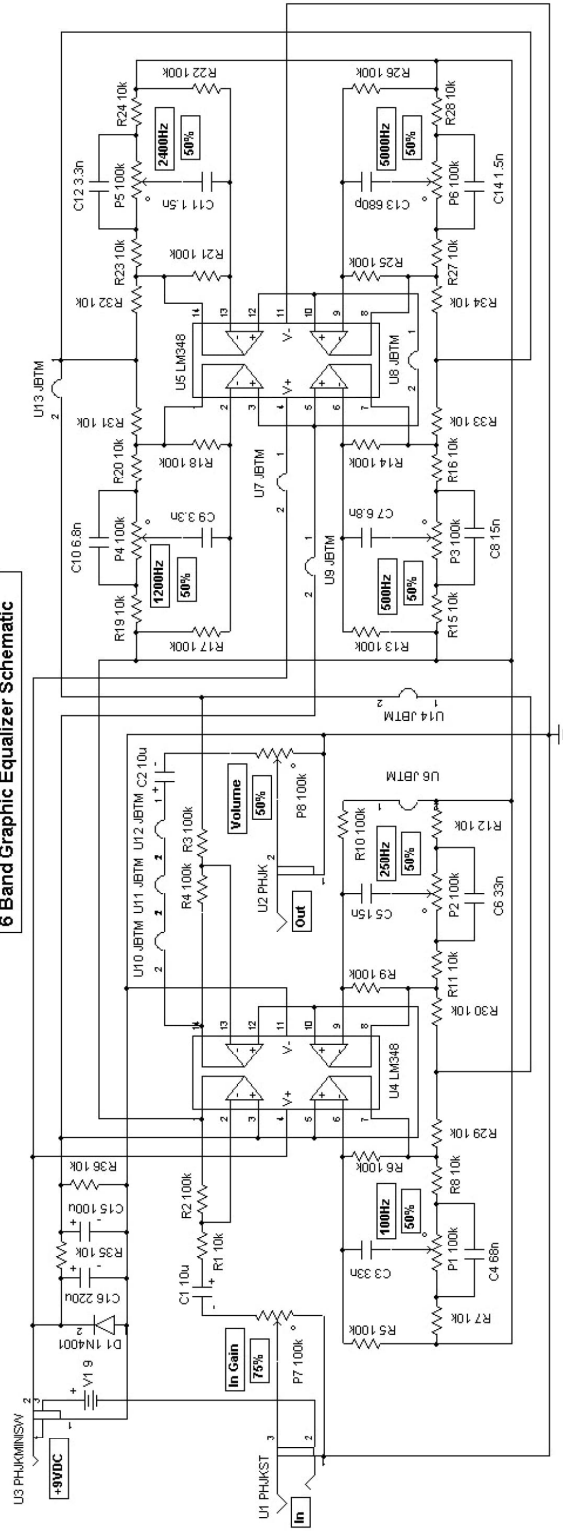

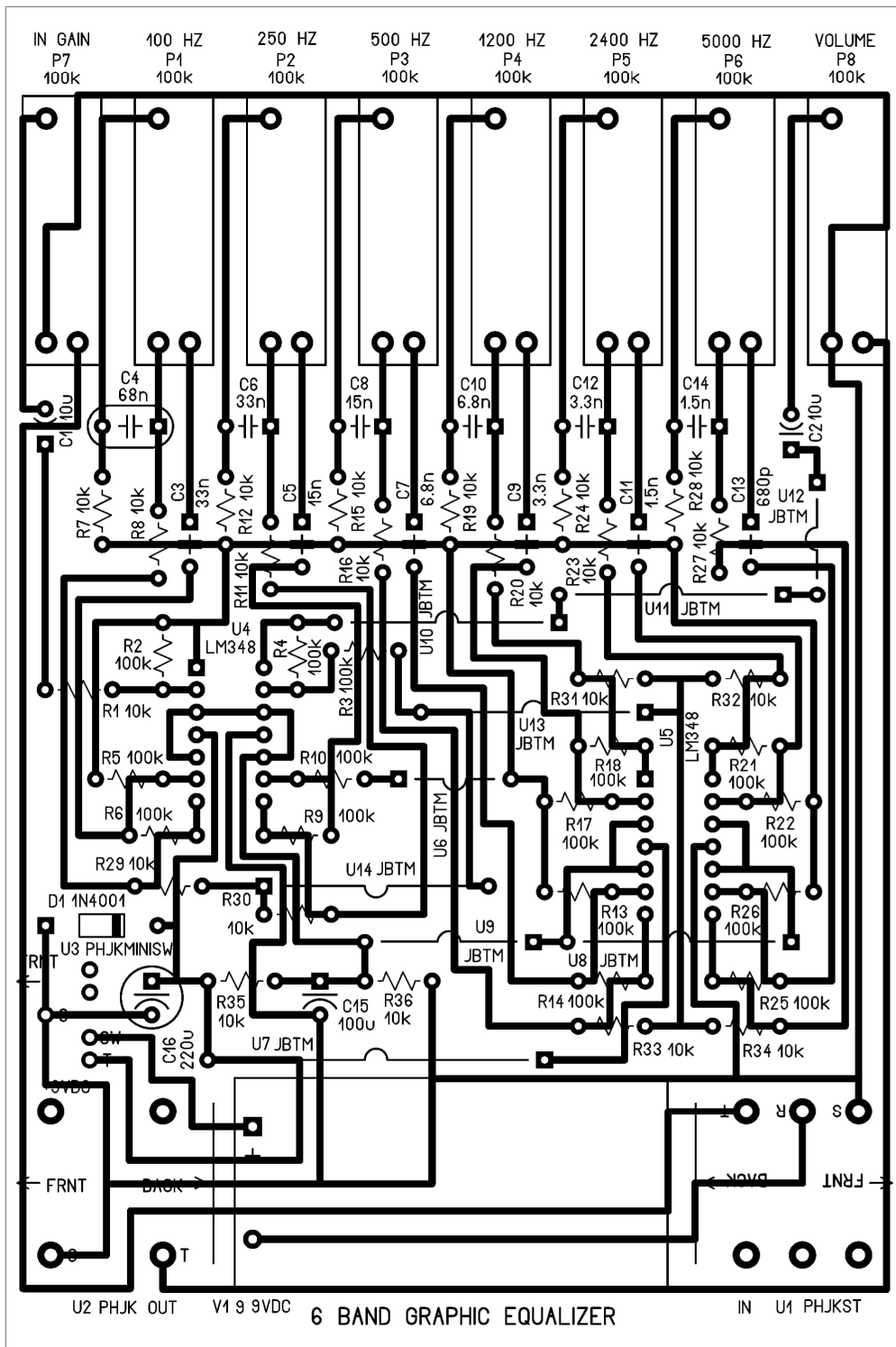

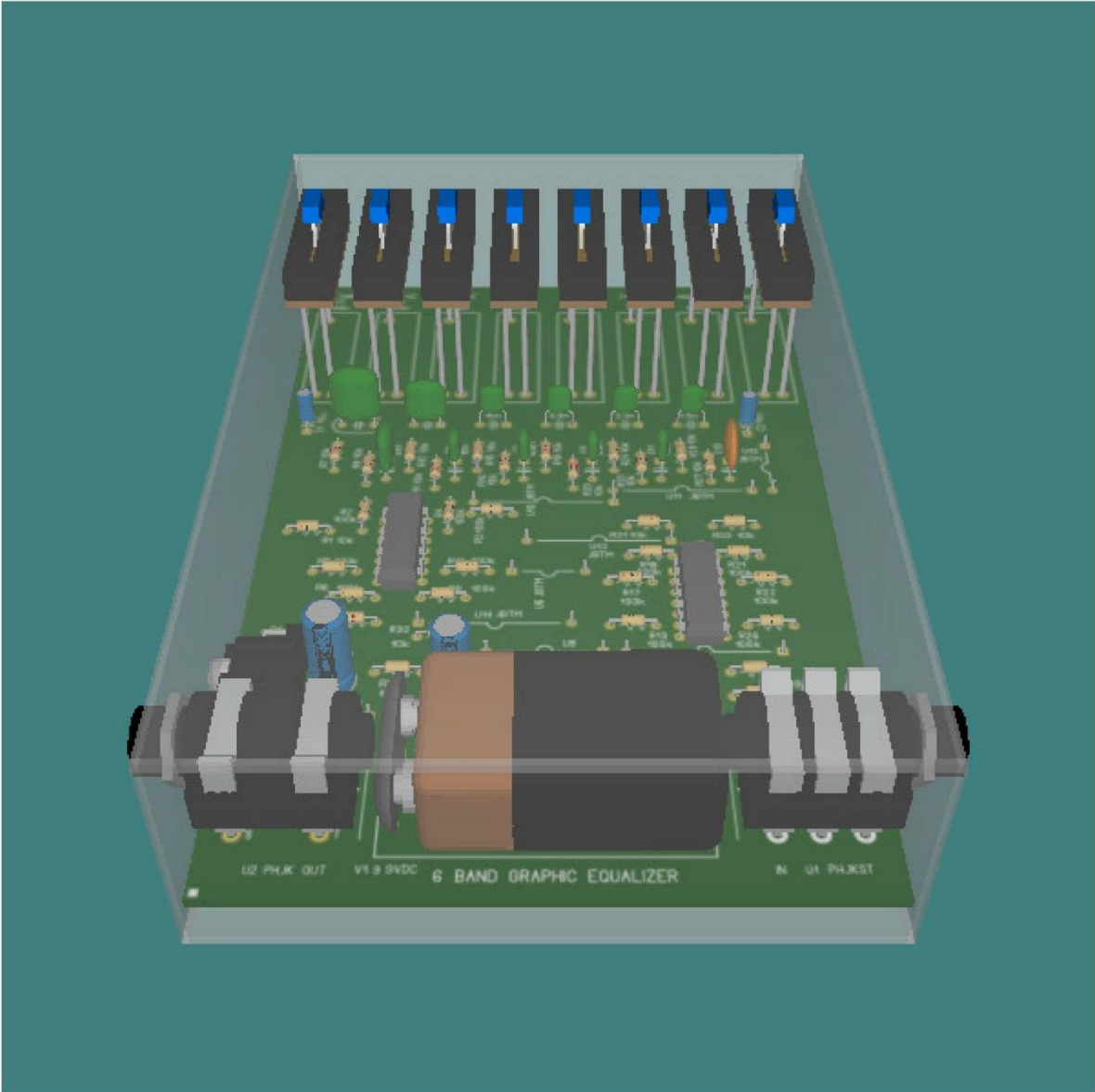

4 Channel Audio Mixer

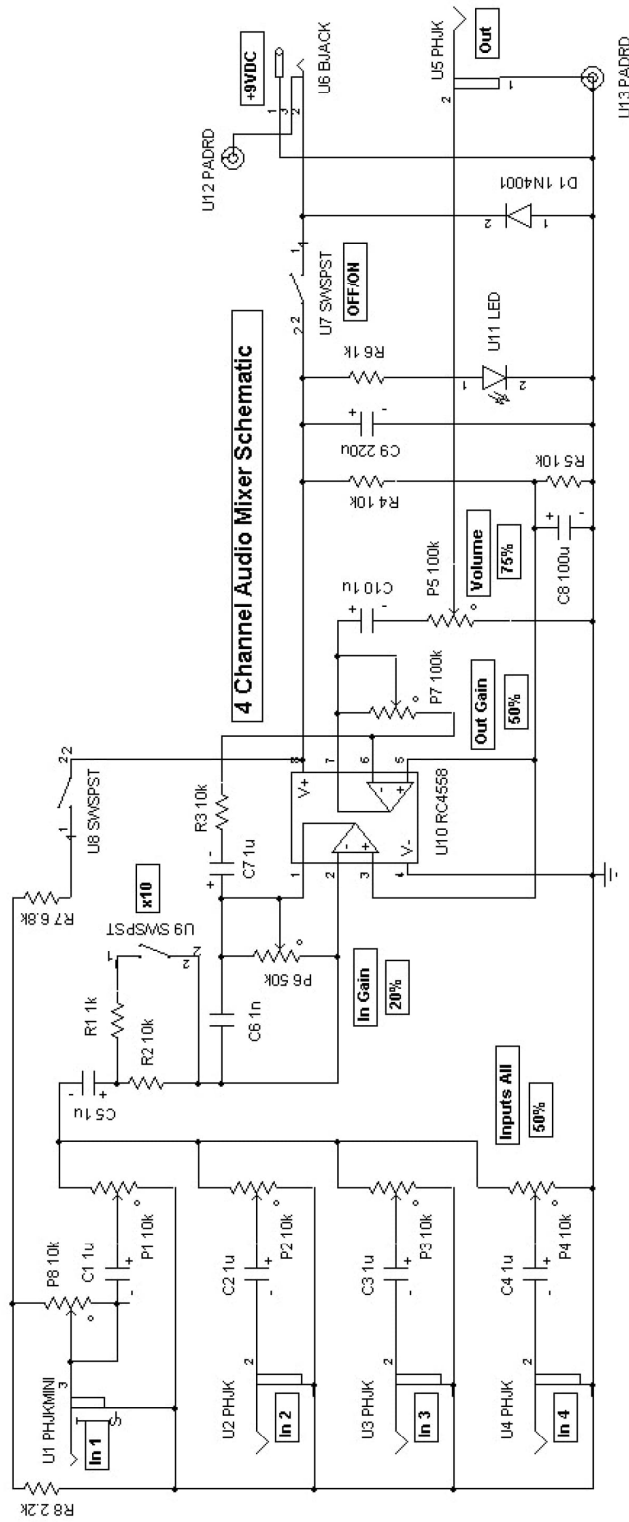

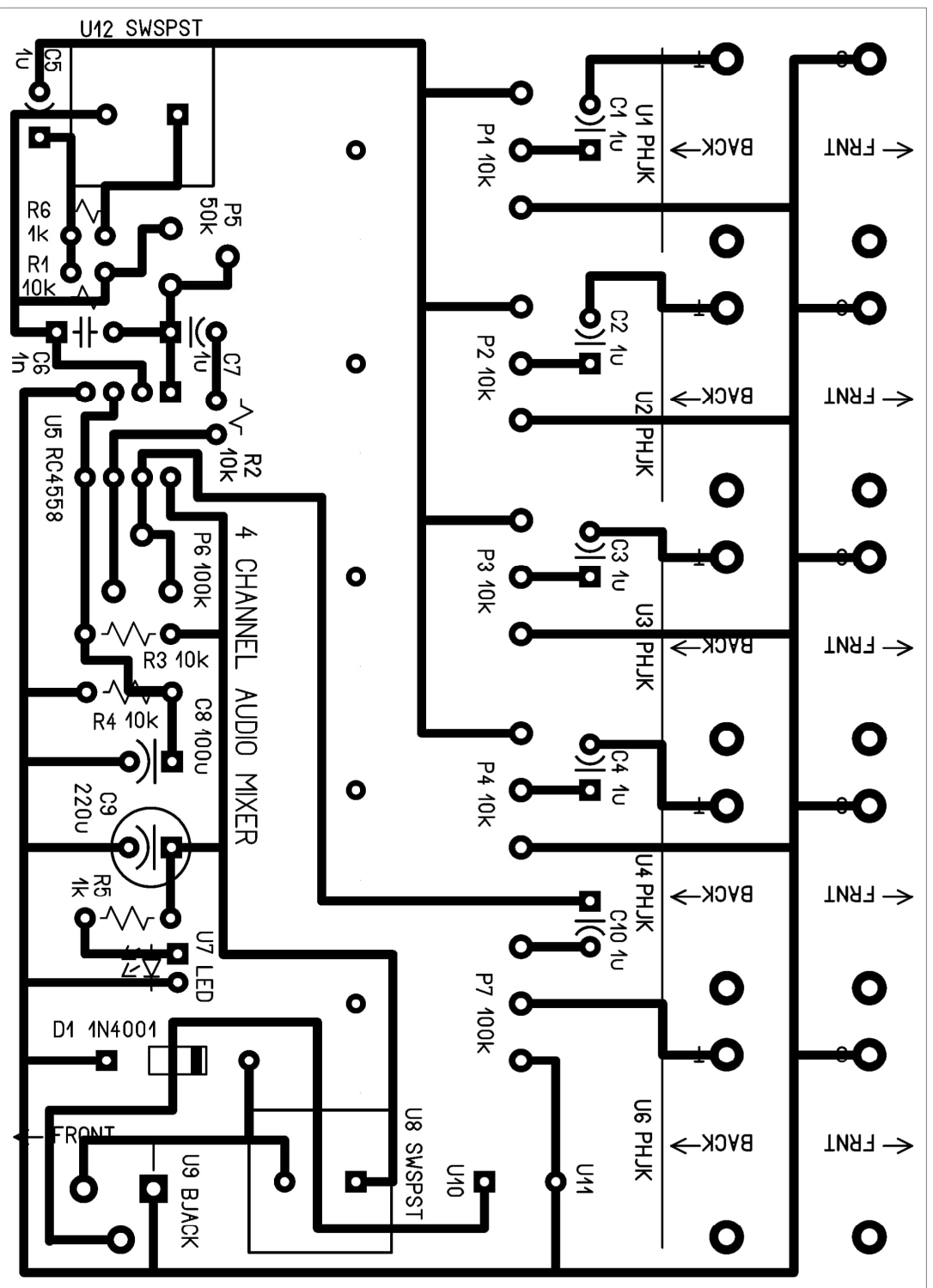



4 Channel Audio Mixer 2

4 Channel Audio Mixer 2 Schematic

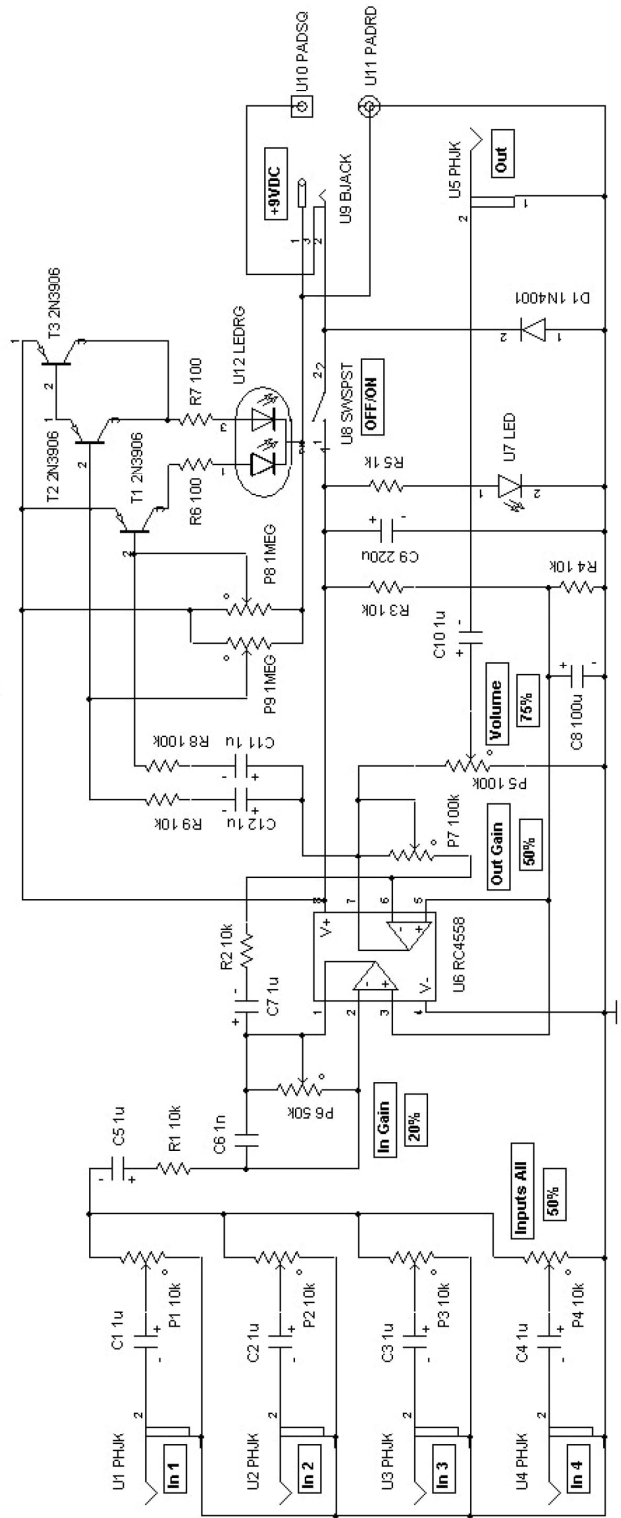

4 CHANNEL AUDIO MIXER 2

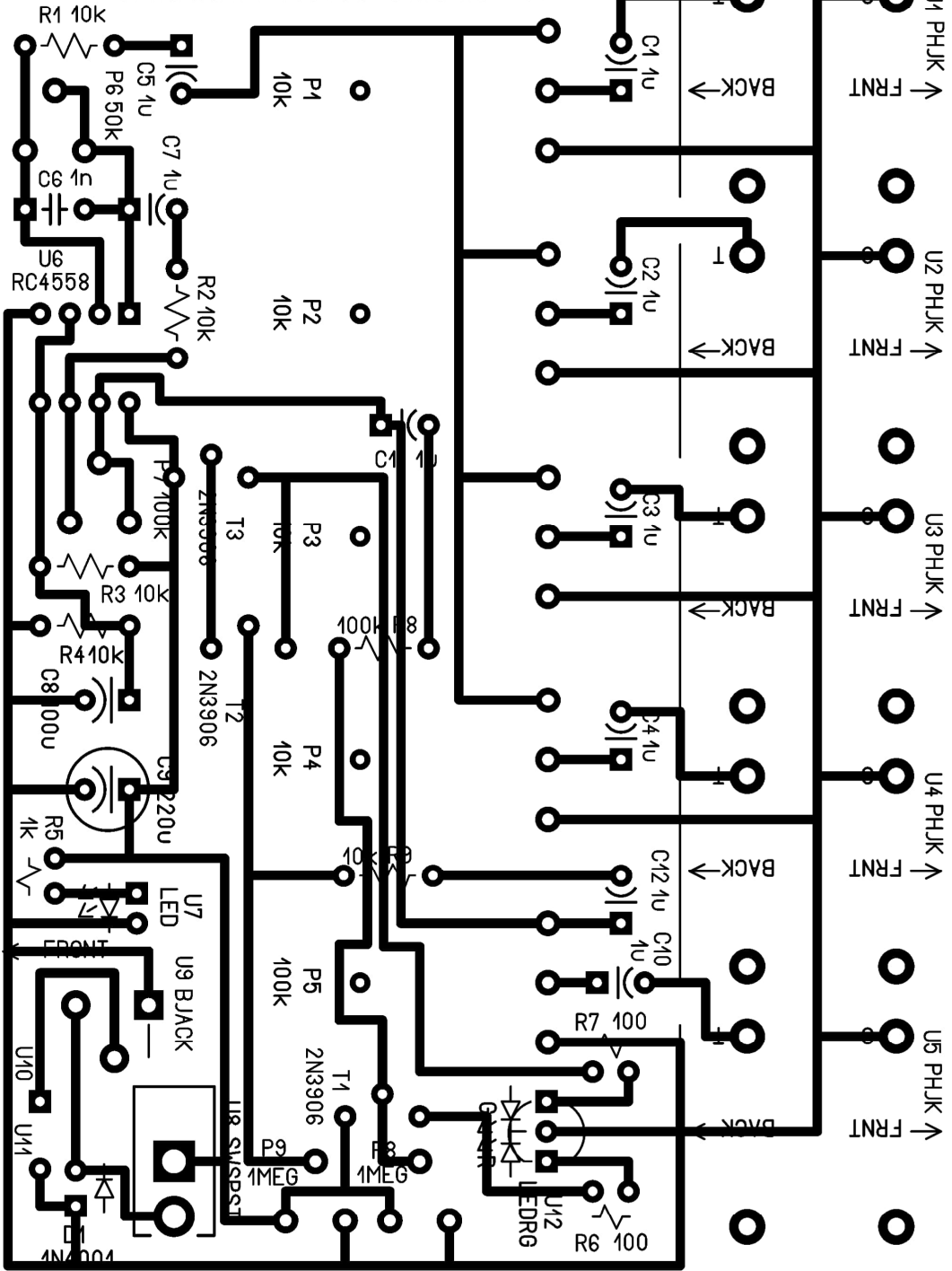

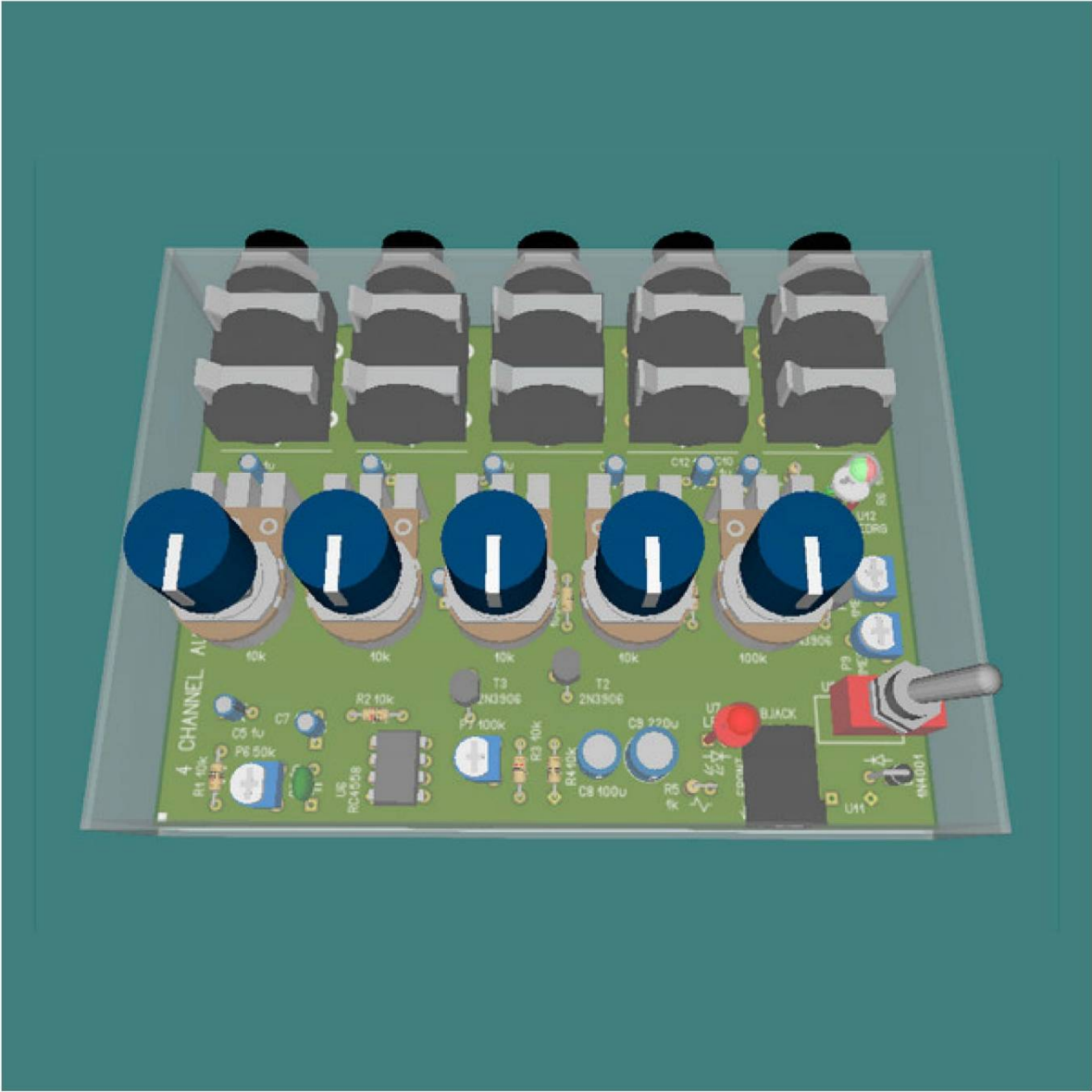

Audio Overdub Mixer

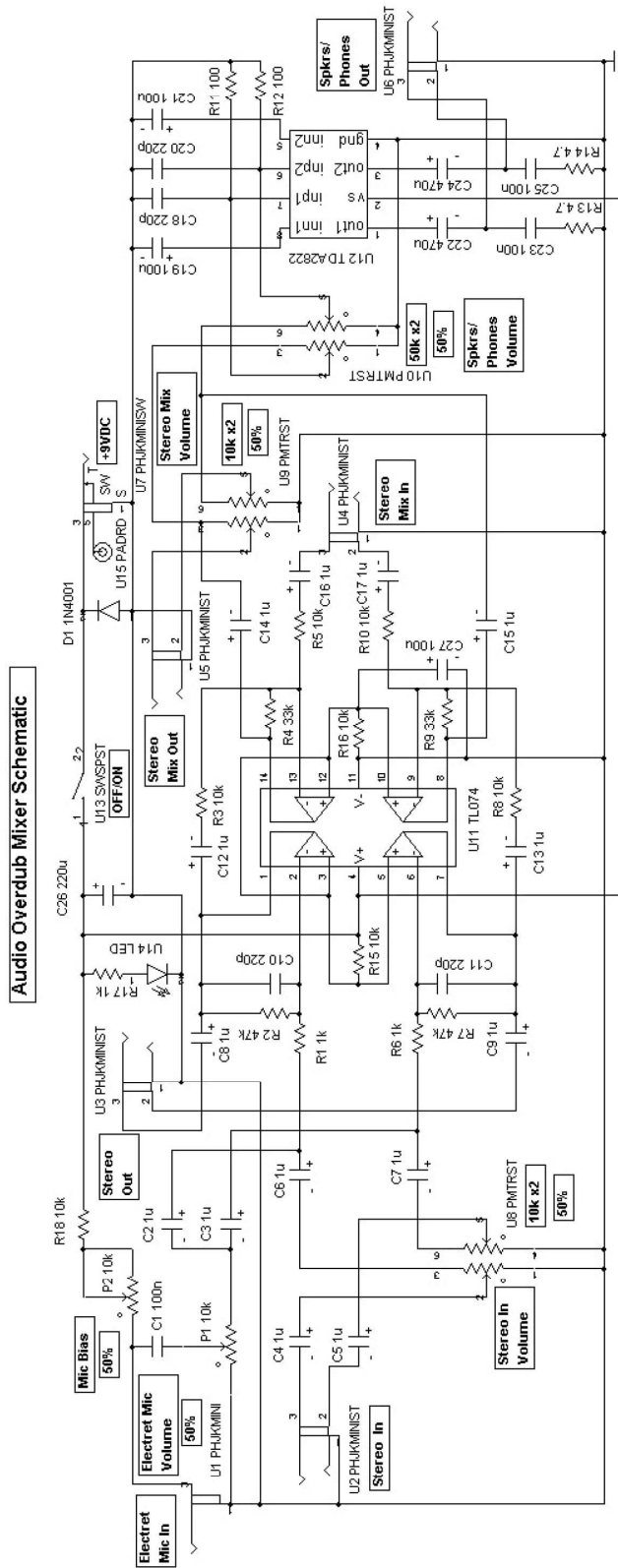

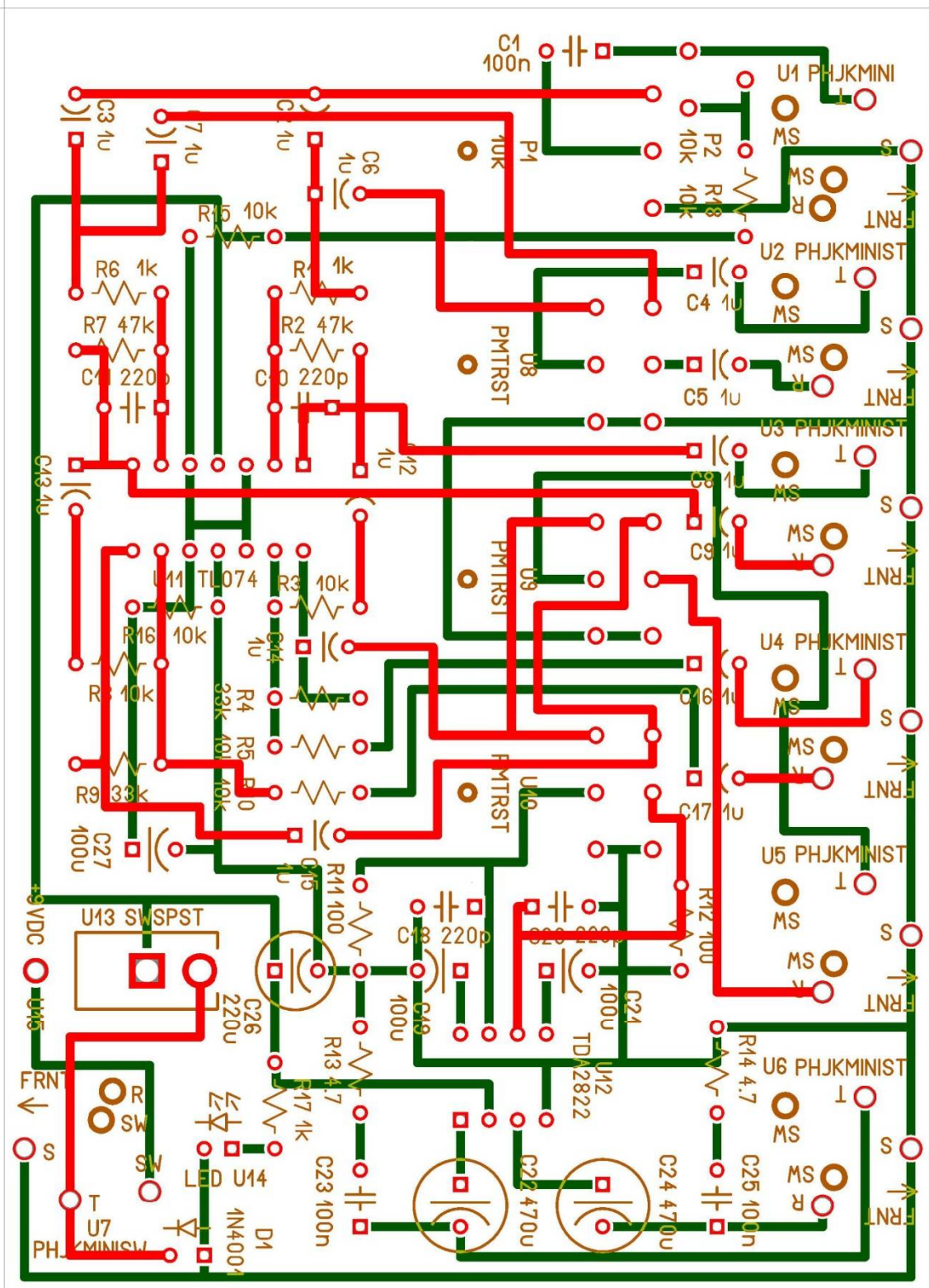

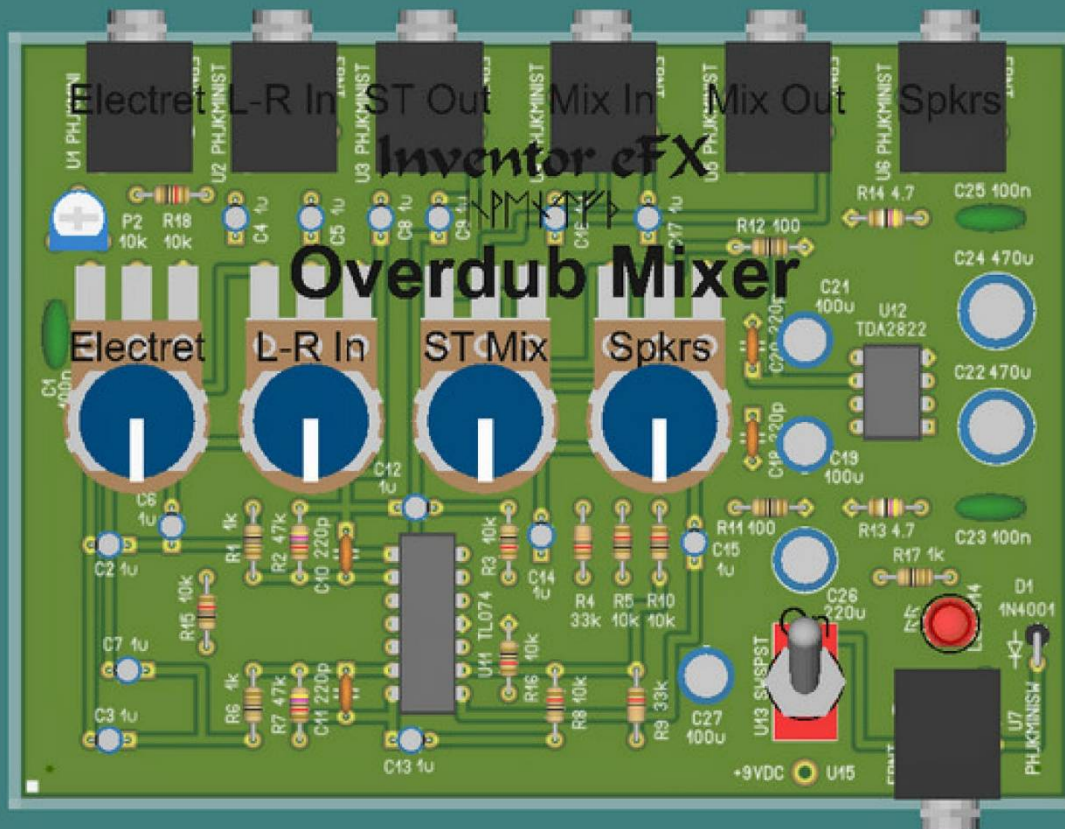

Audio Overdub Mixer 1

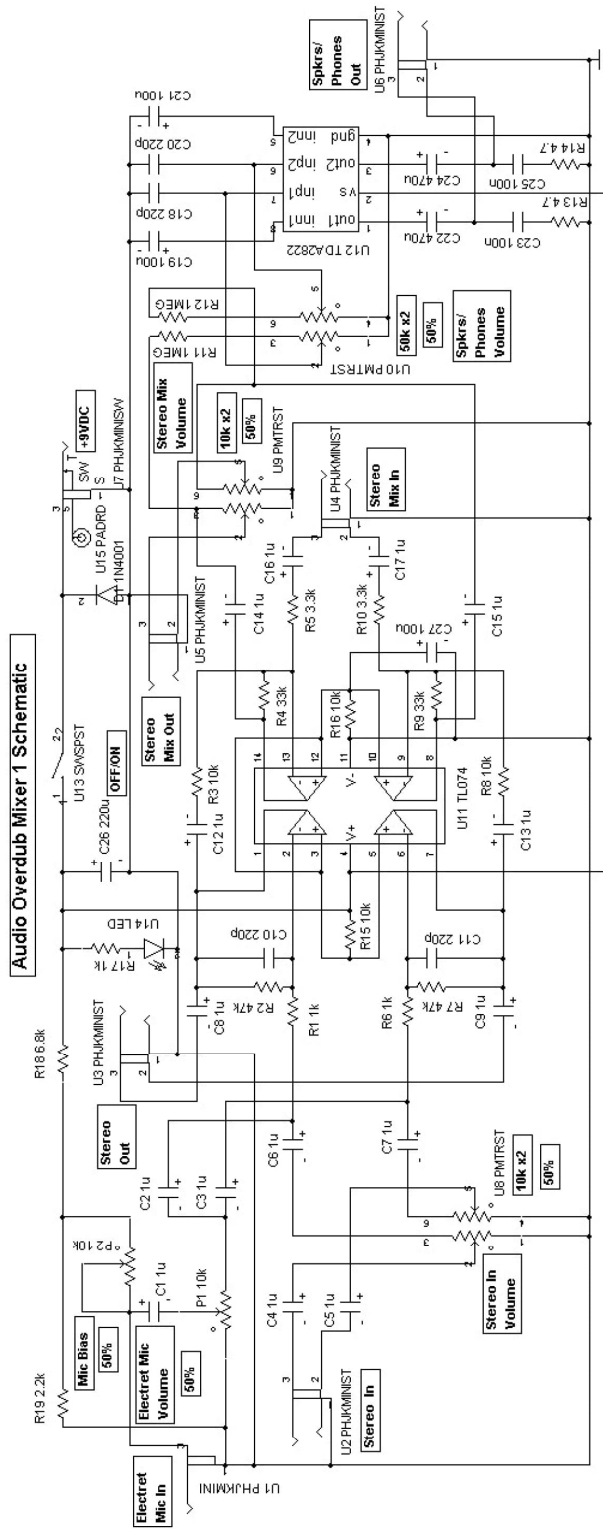

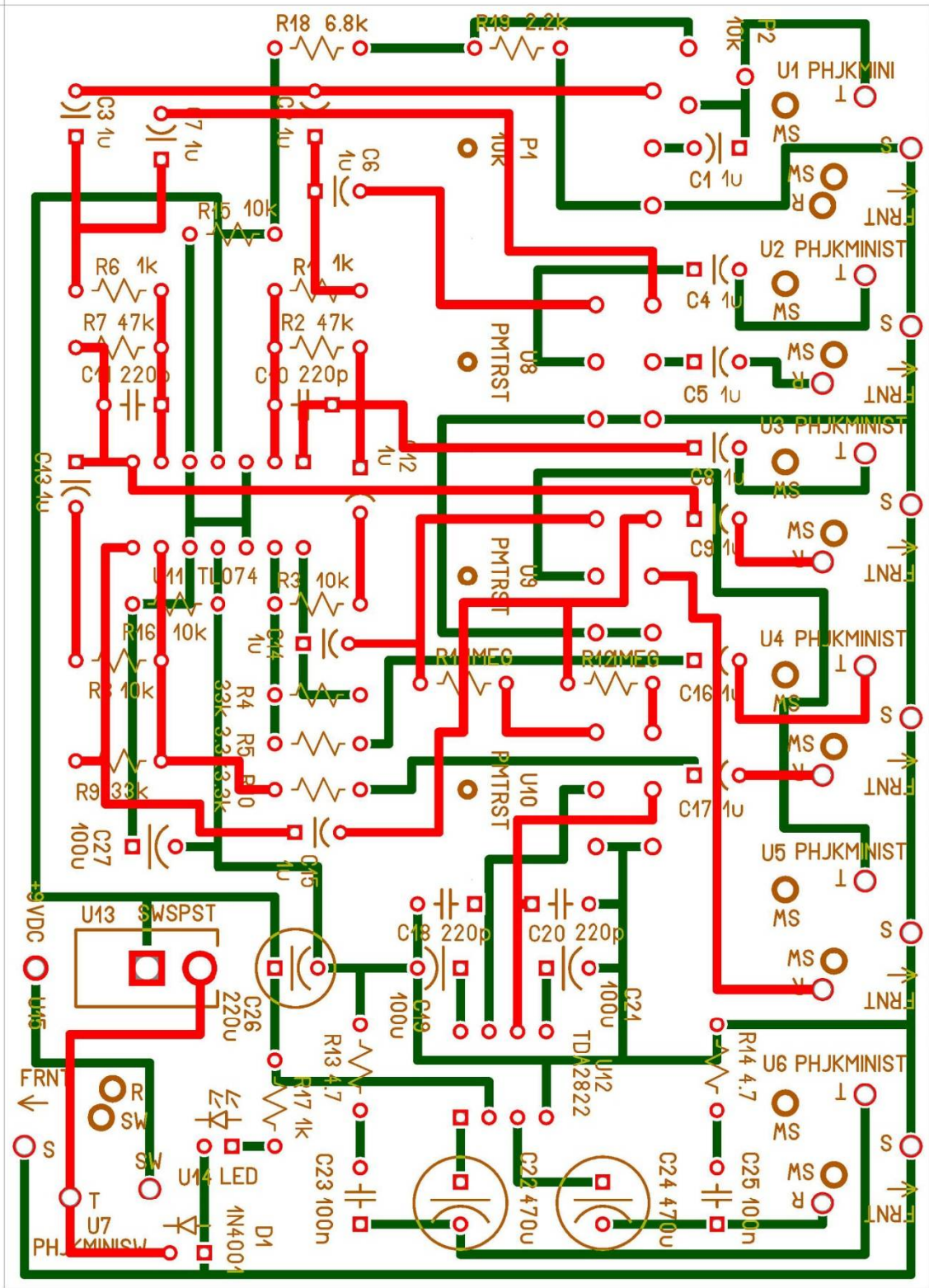

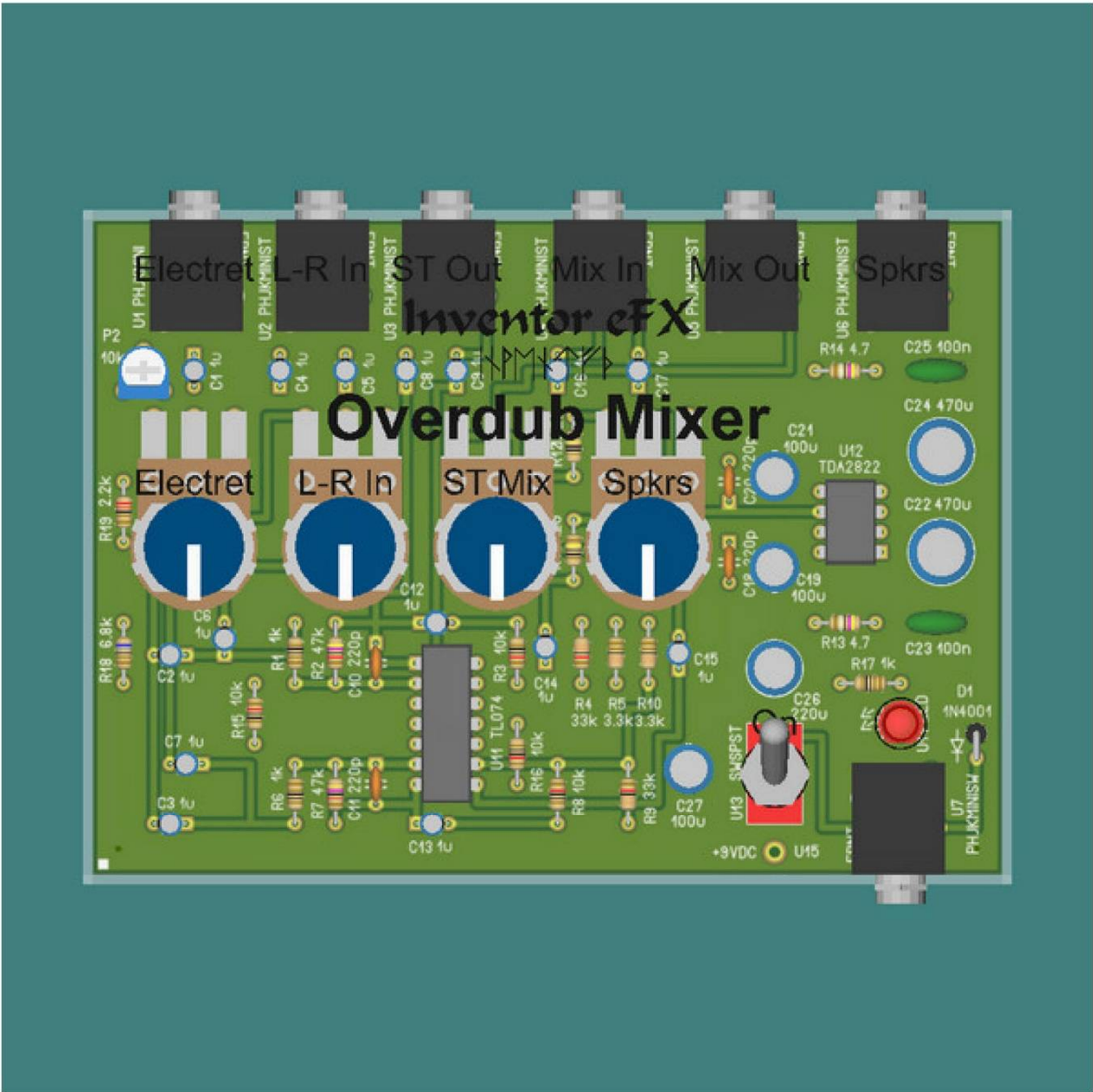

Audio Overdub Mixer 2

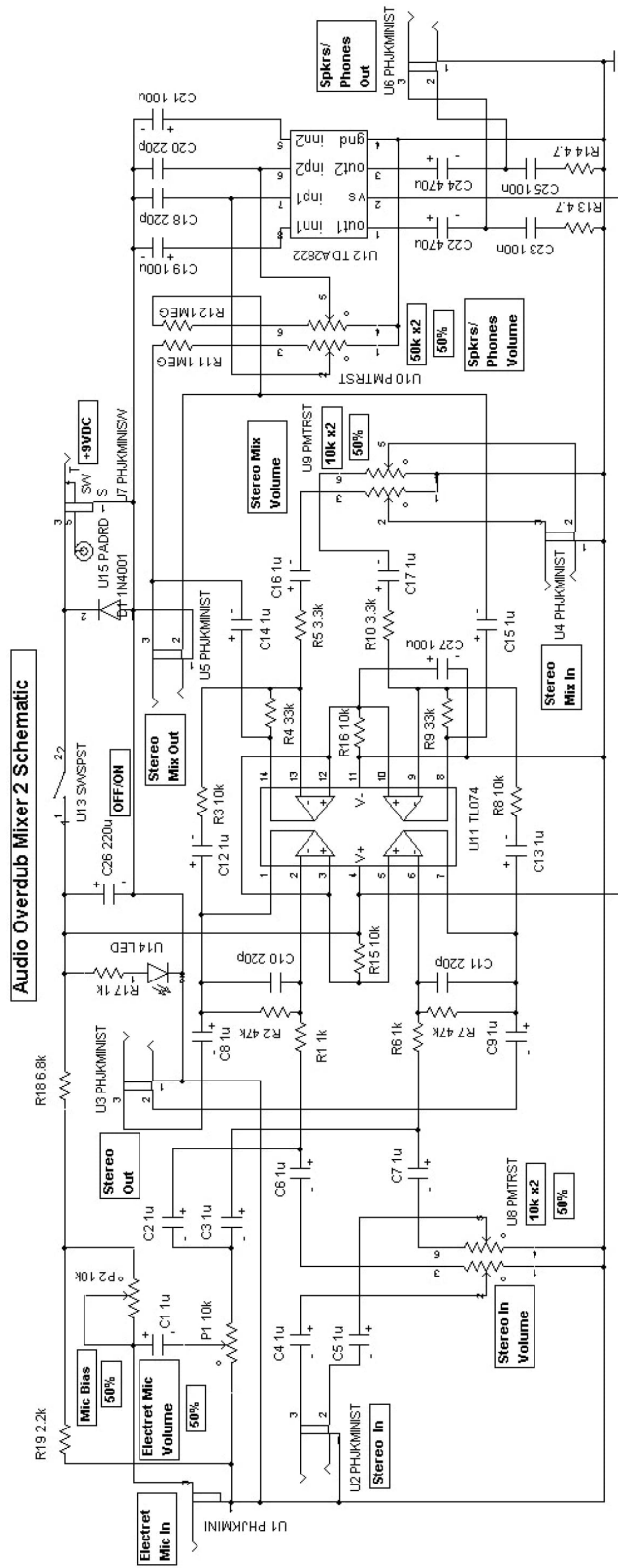

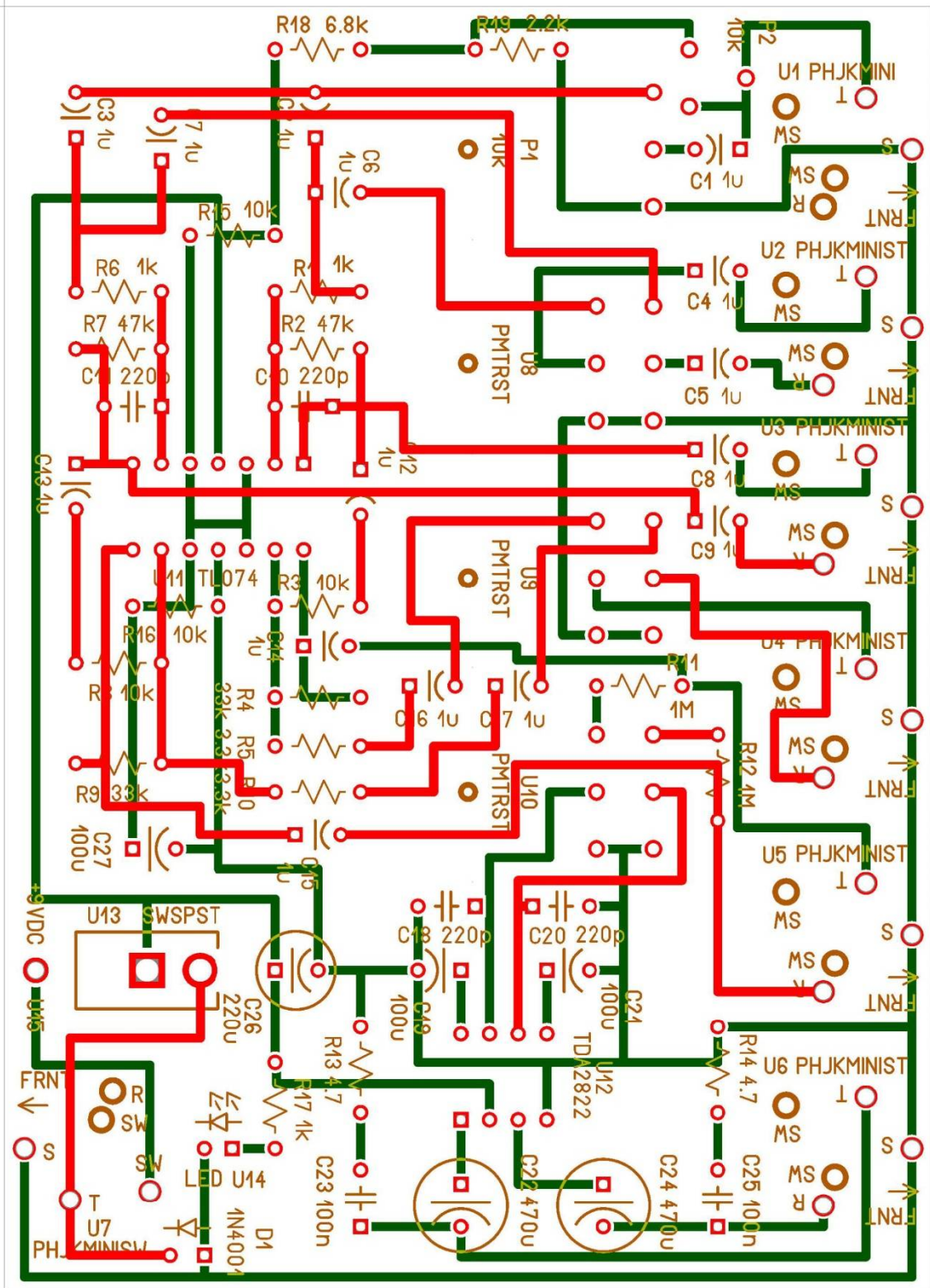

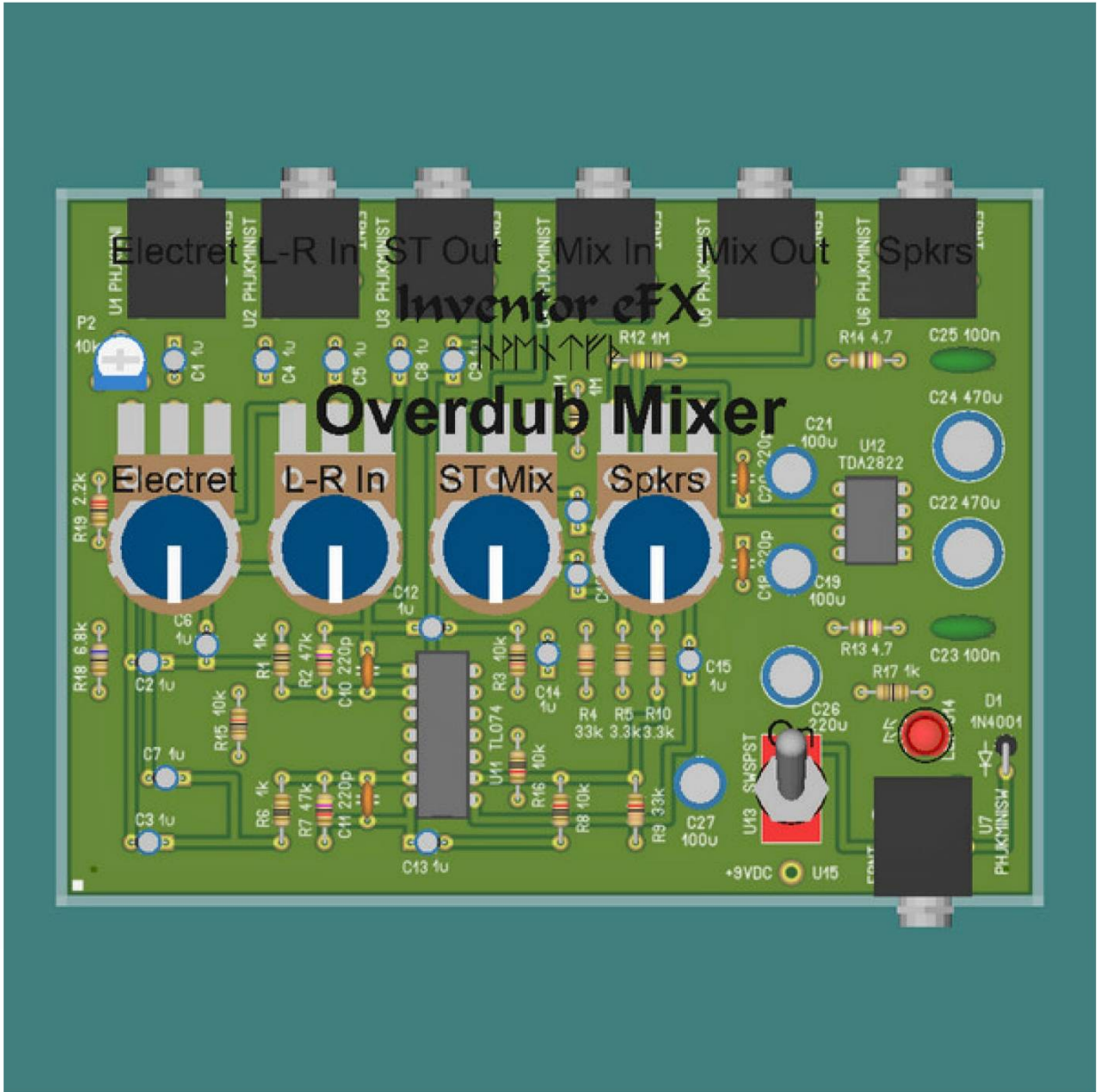

Audio Overdub Mixer 3

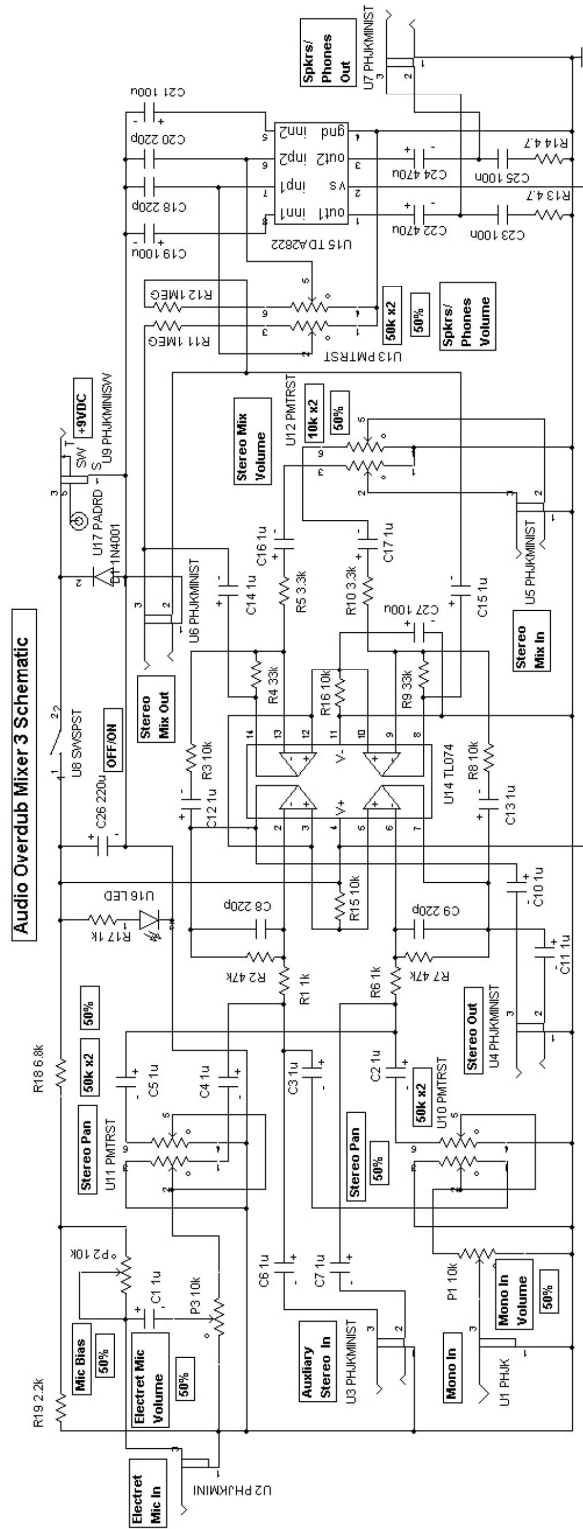

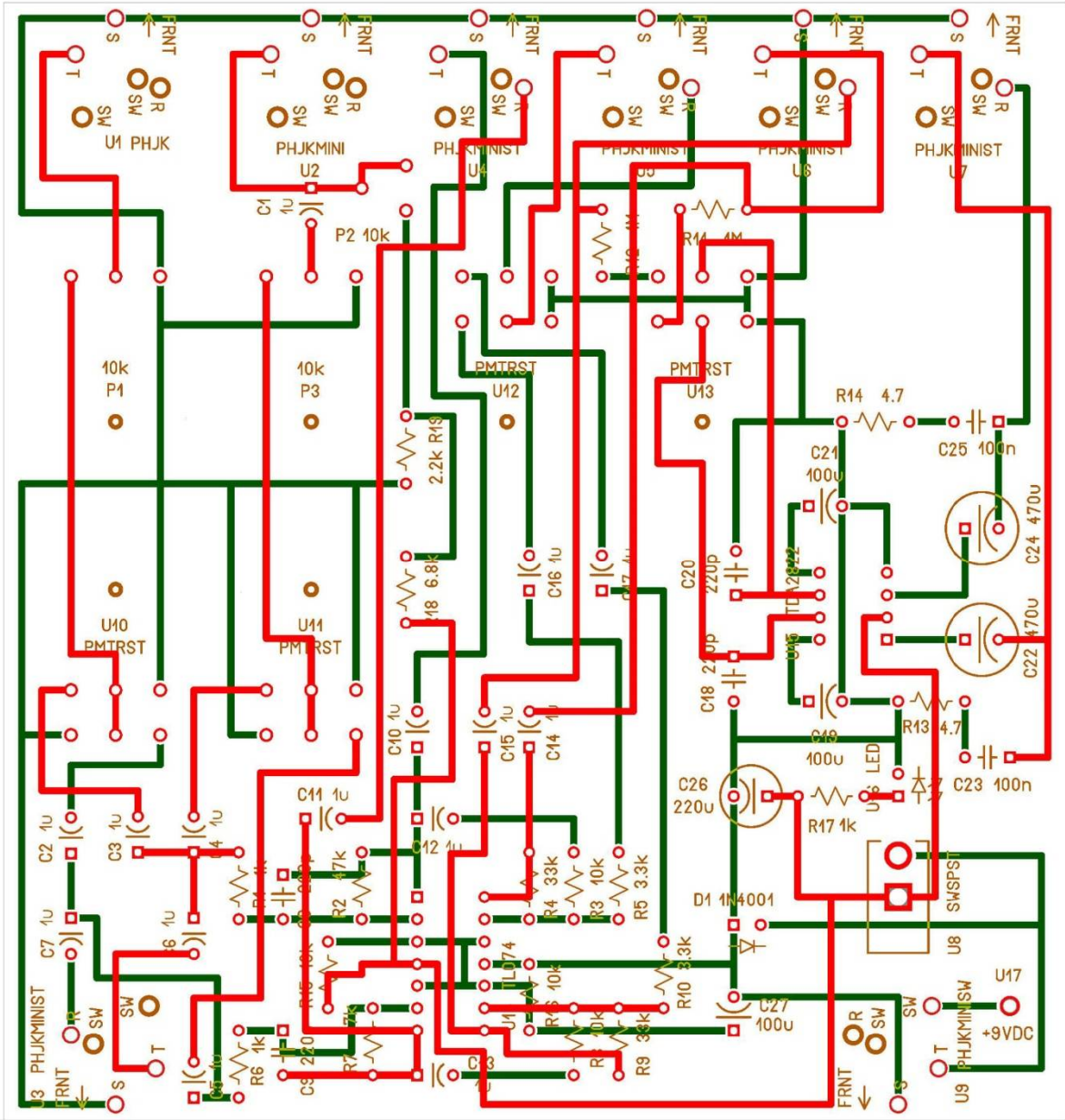

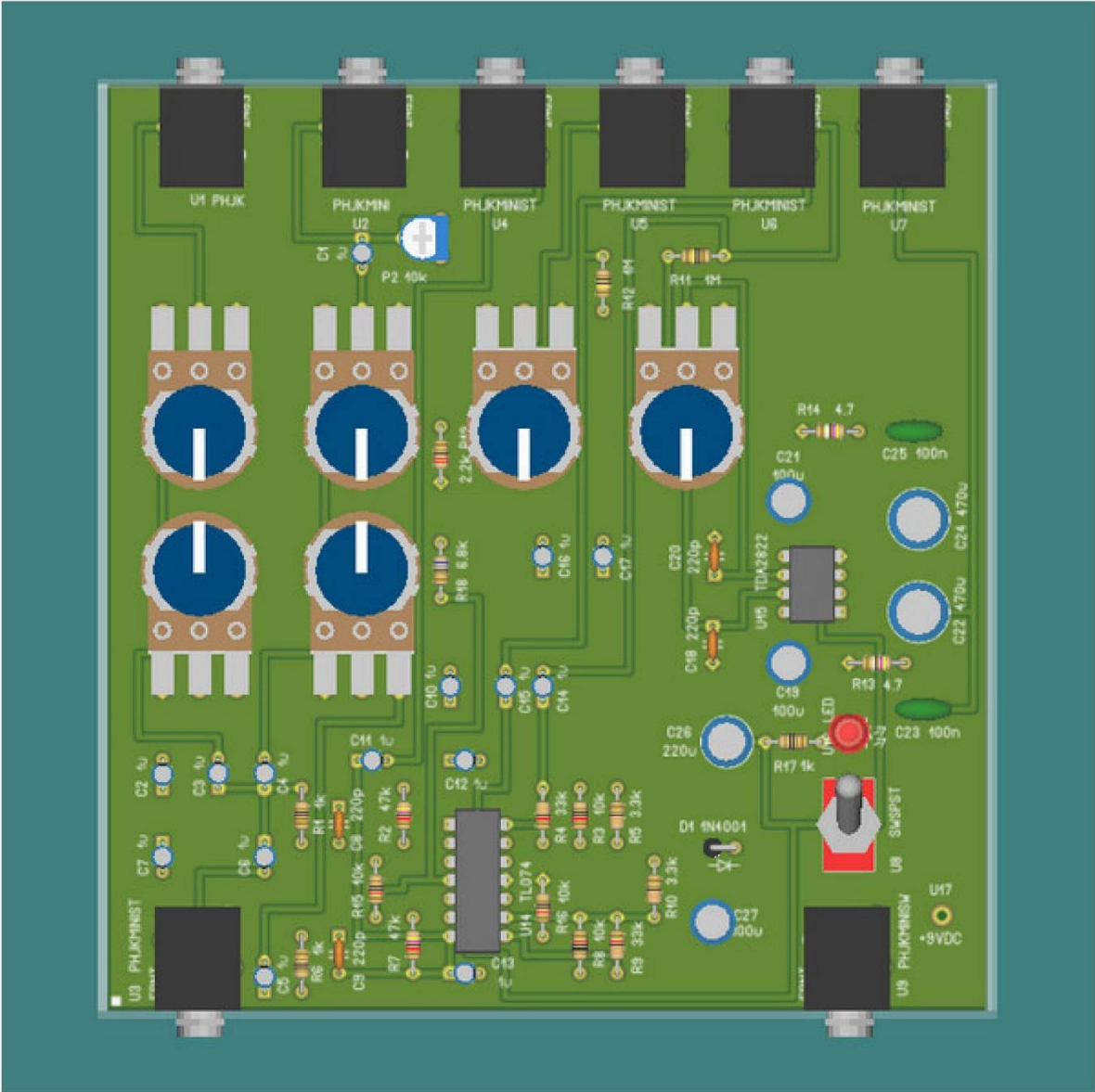

4-Input 2-Output Audio Mixer Schematic

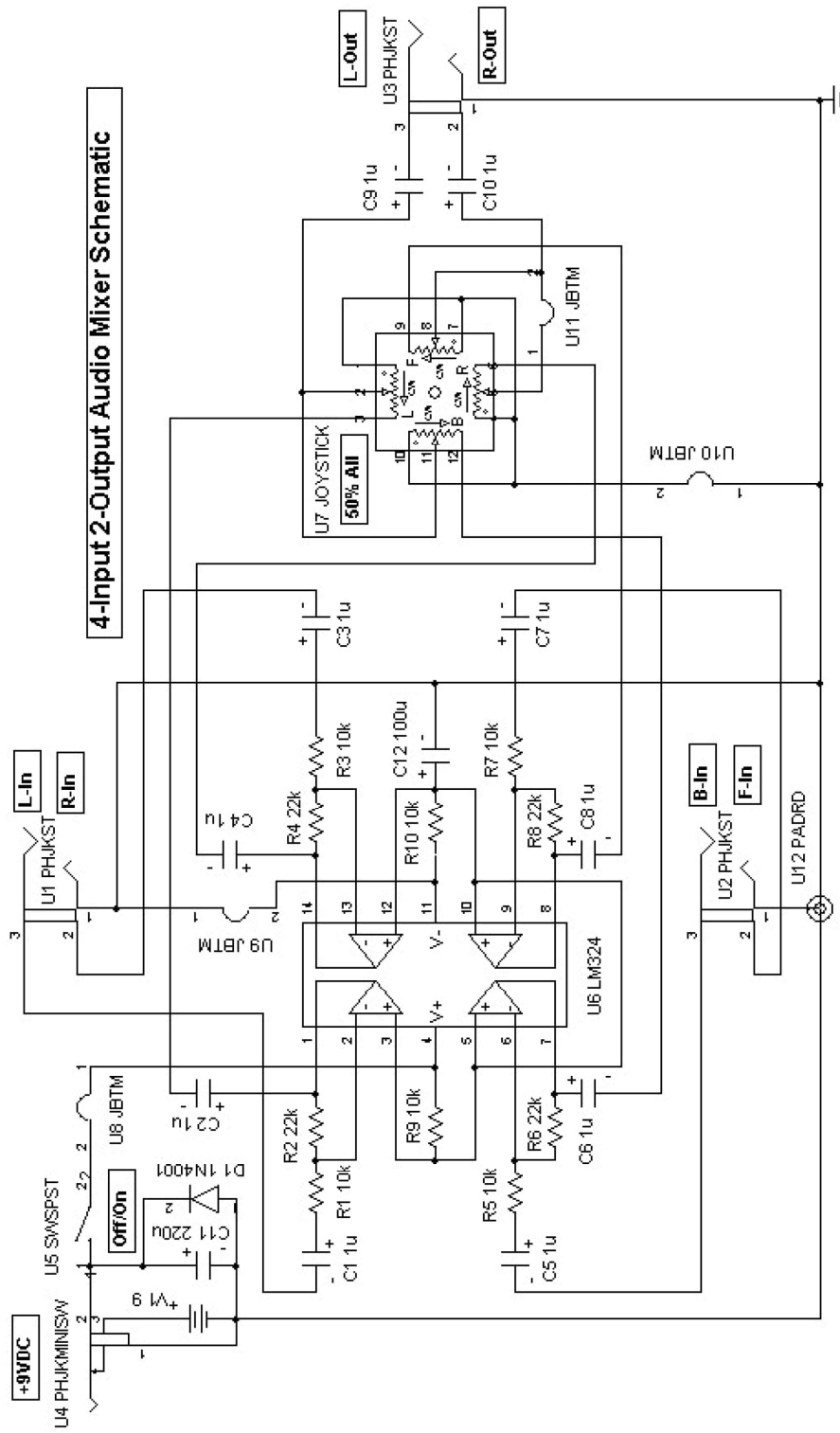

4-INPUT 2-OUTPUT AUDIO MIXER

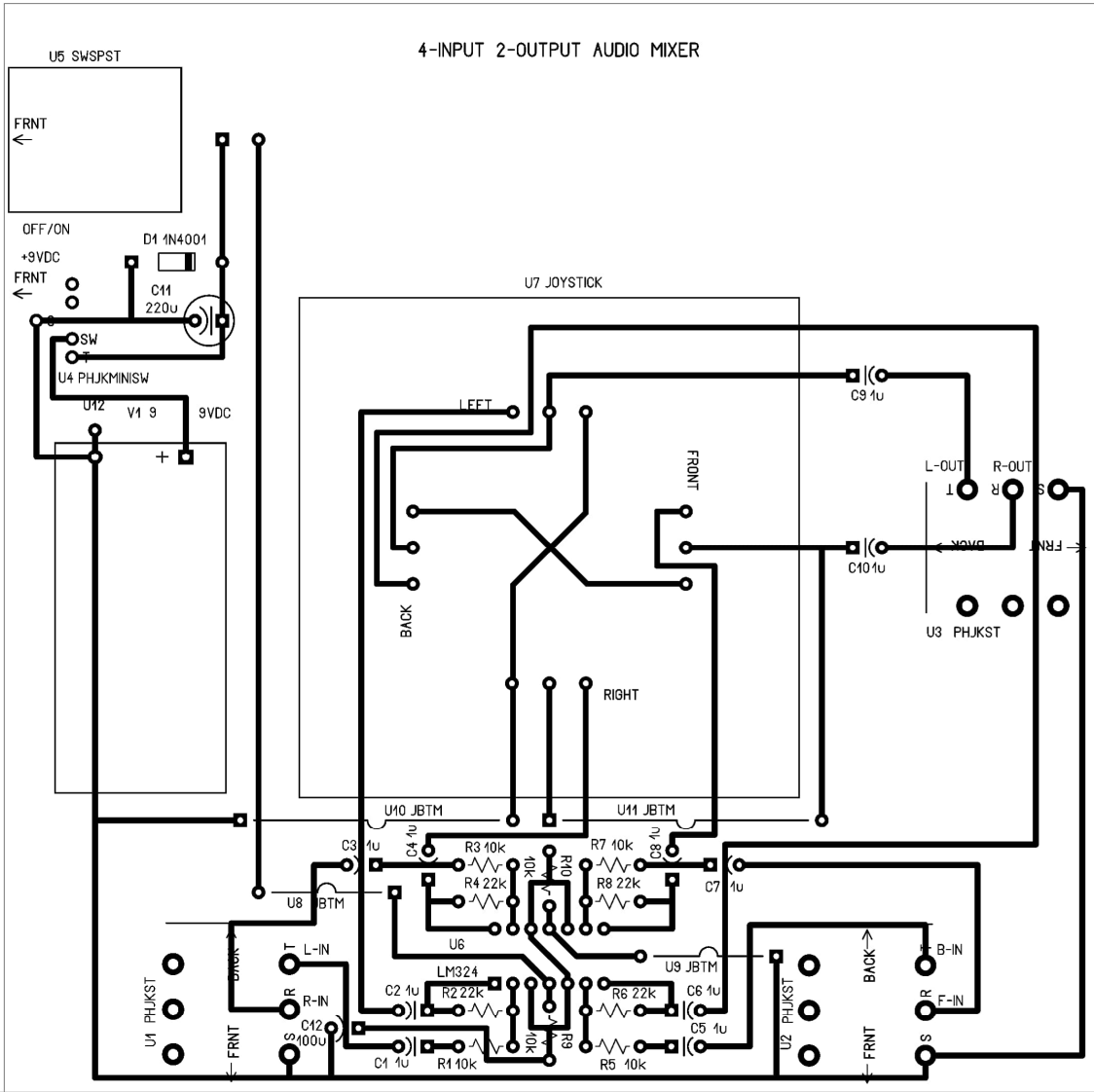

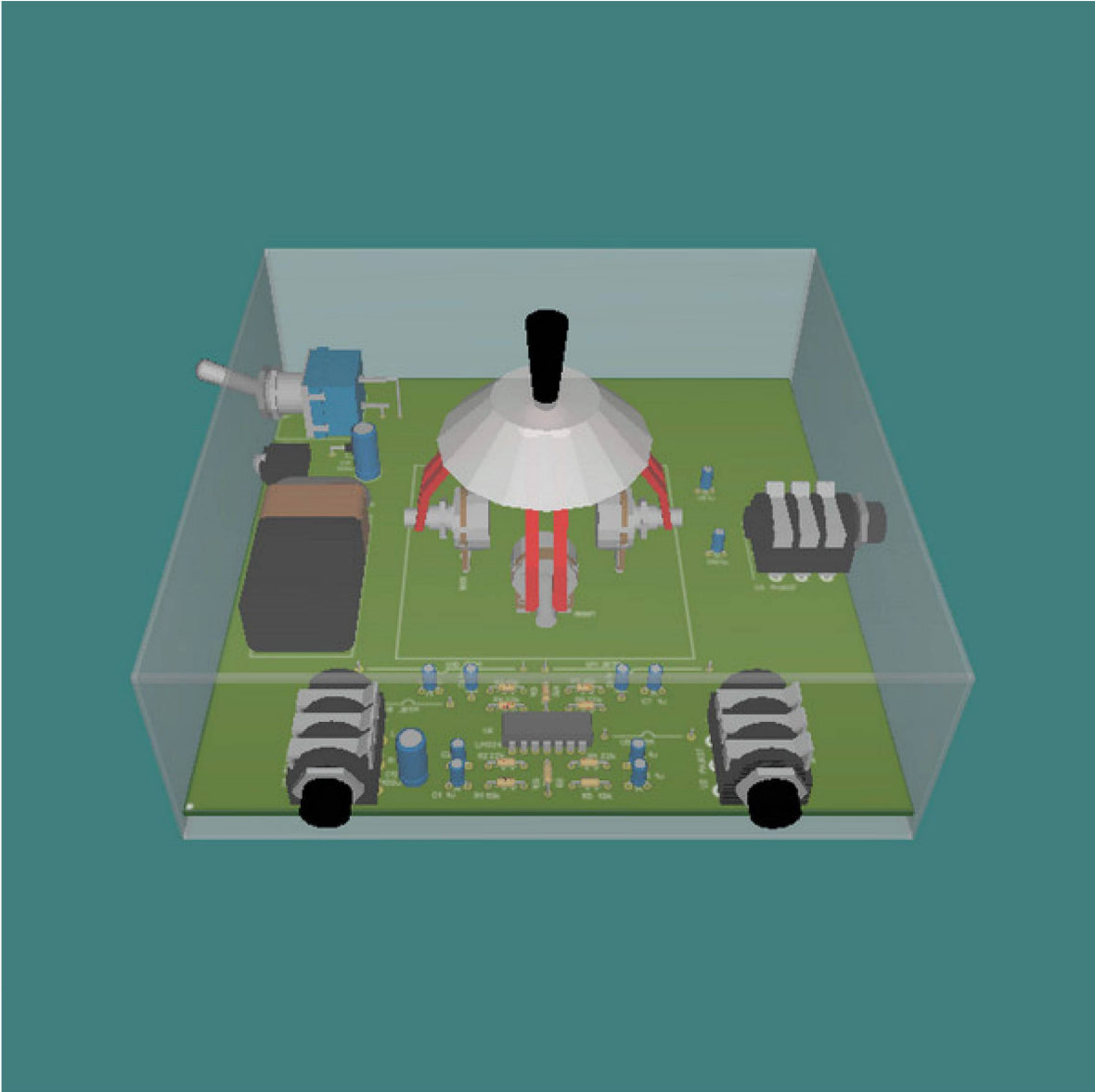

AAA Fuzz 1

AAA FUZZ 1 Schematic

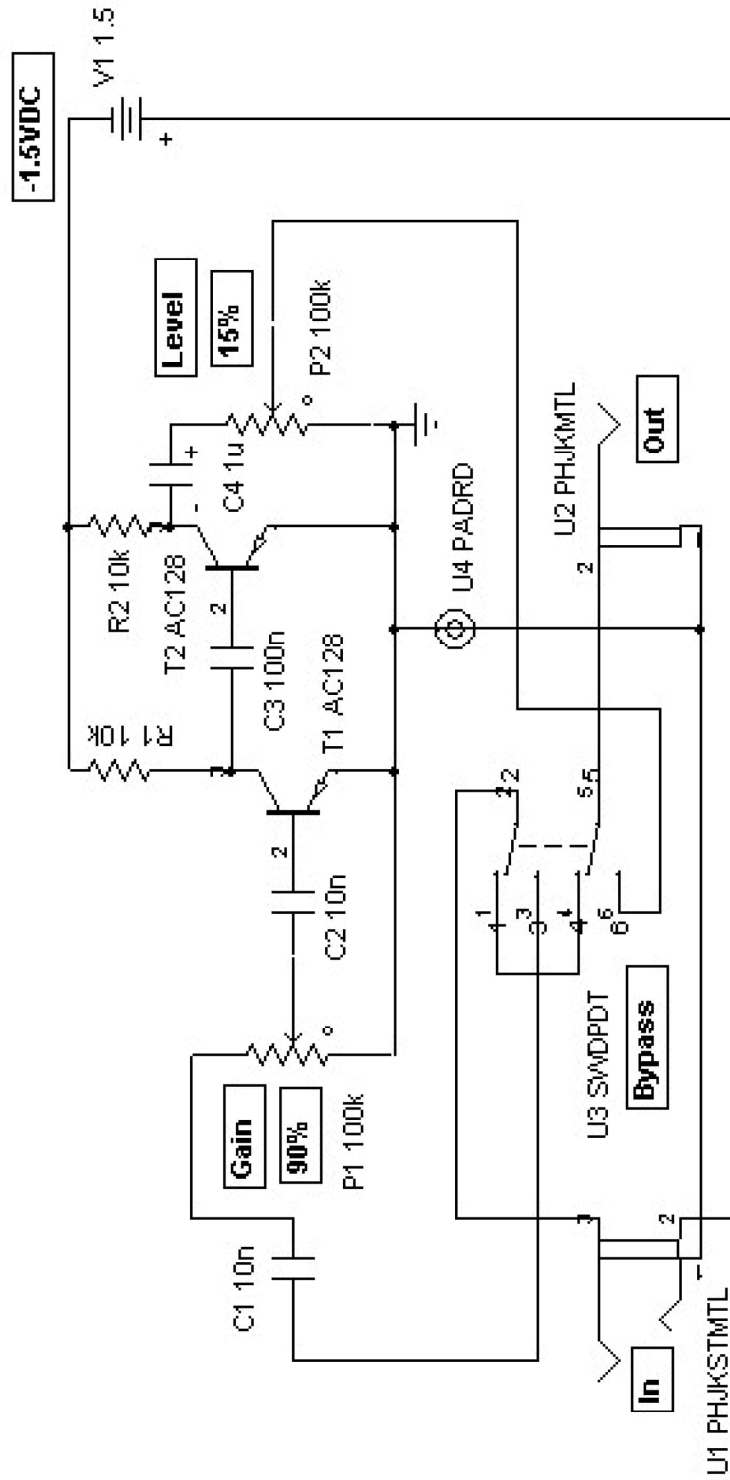

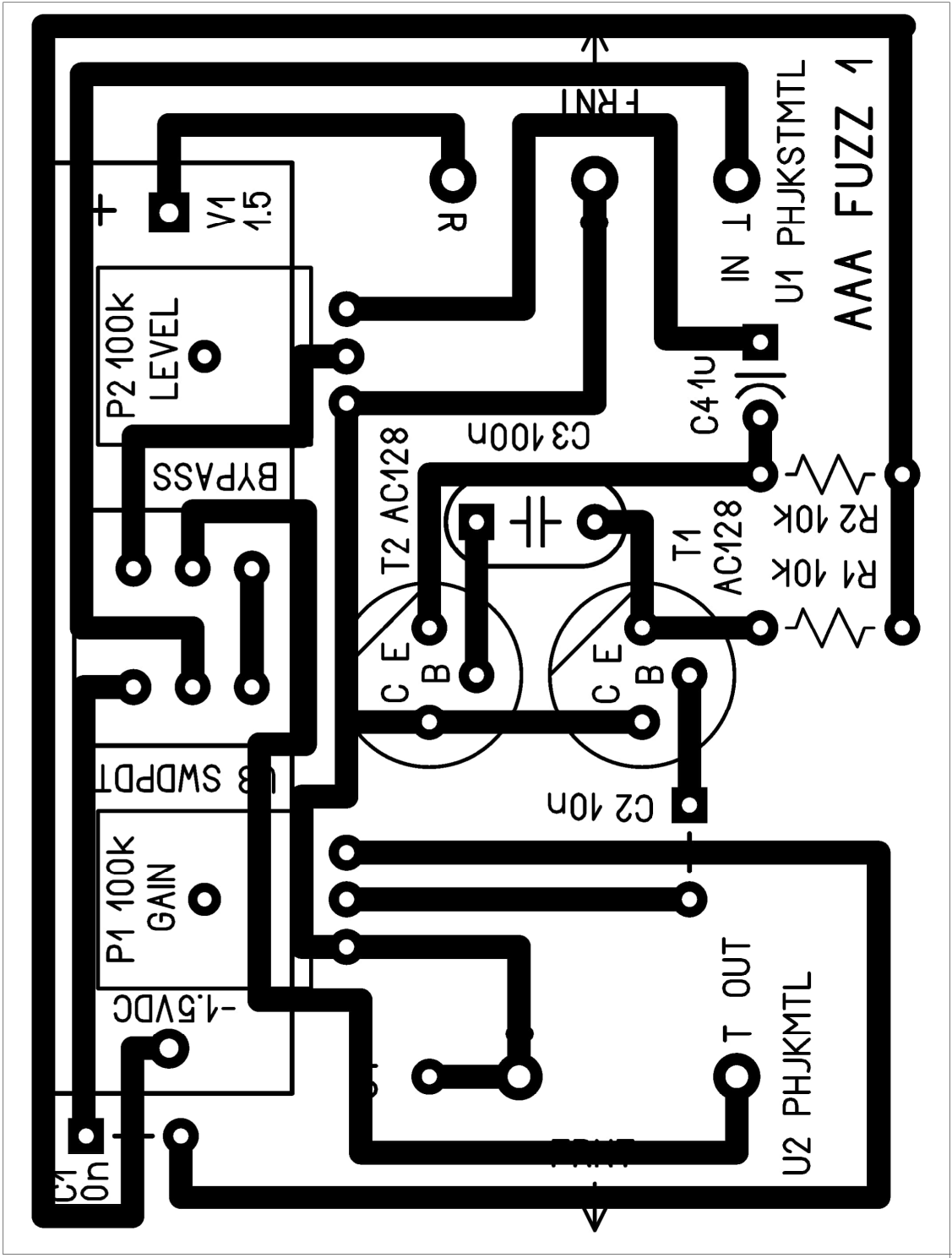

C1
10n

-1.5VDC

P1 100k
GAIN

BYPASS

P2 100k
LEVEL

V1
1.5

T1

C

E

B

AC128

T2

C

E

B

AC128

R1

10k

R2

10k

C2

10n

C3

100n

C4

100n

U1

PHJKSTMTL

AAA FUZZ 1

IN L

U2

PHJKMTL

T OUT

R

F RNT

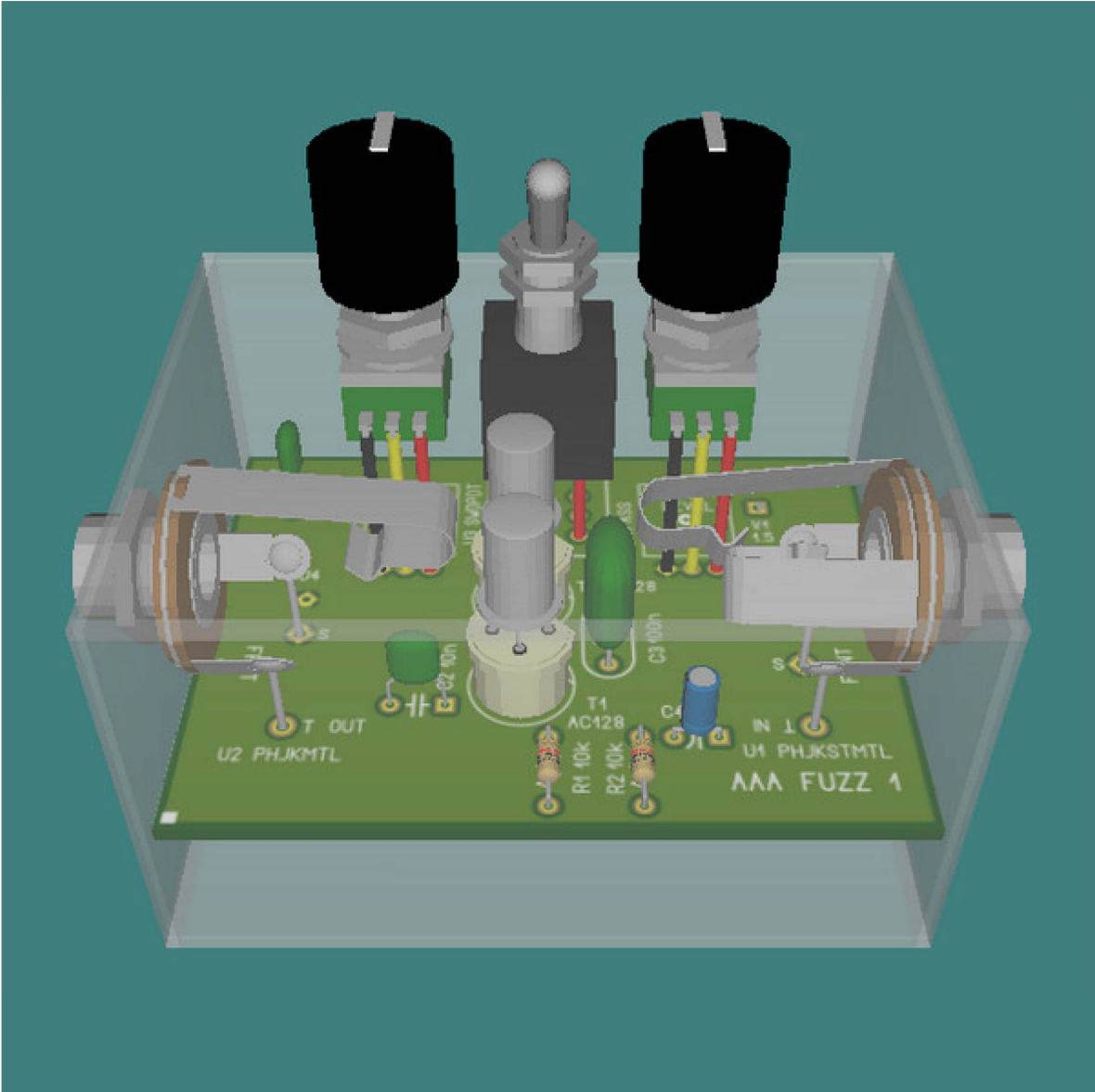

AAA Fuzz 1 BRD

AAA FUZZ 1 PC Board Schematic

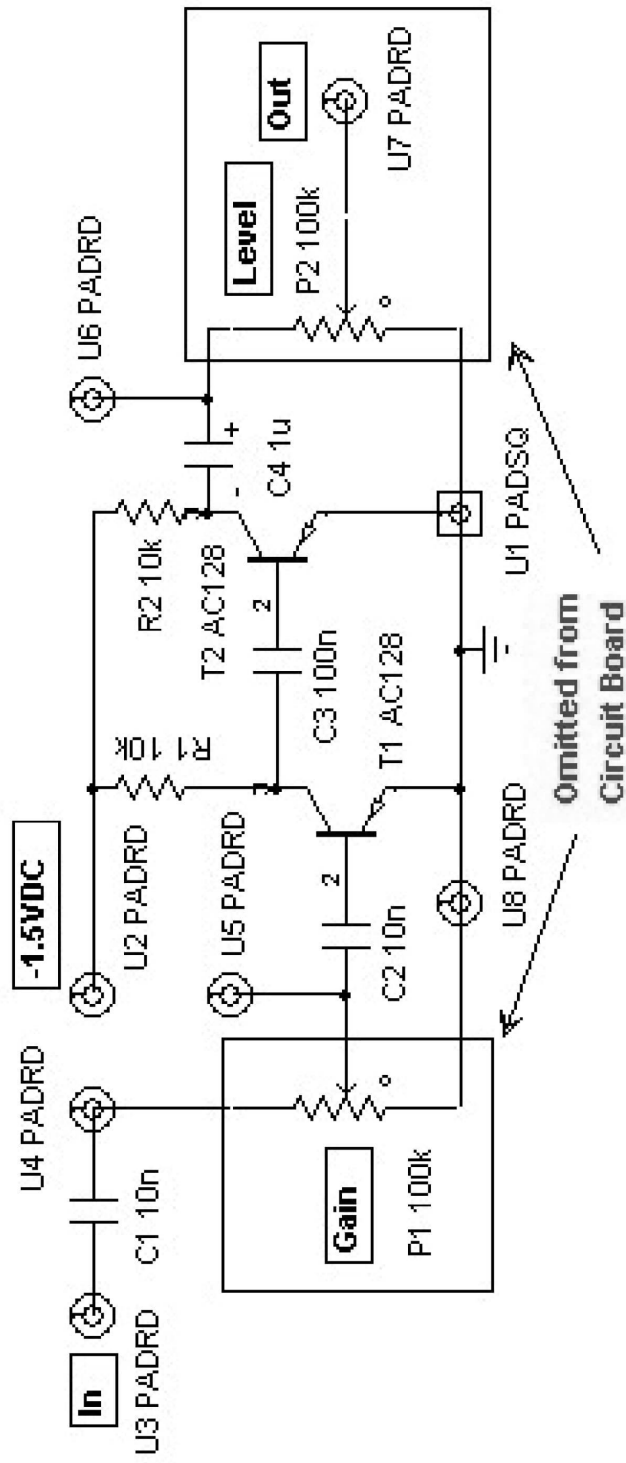

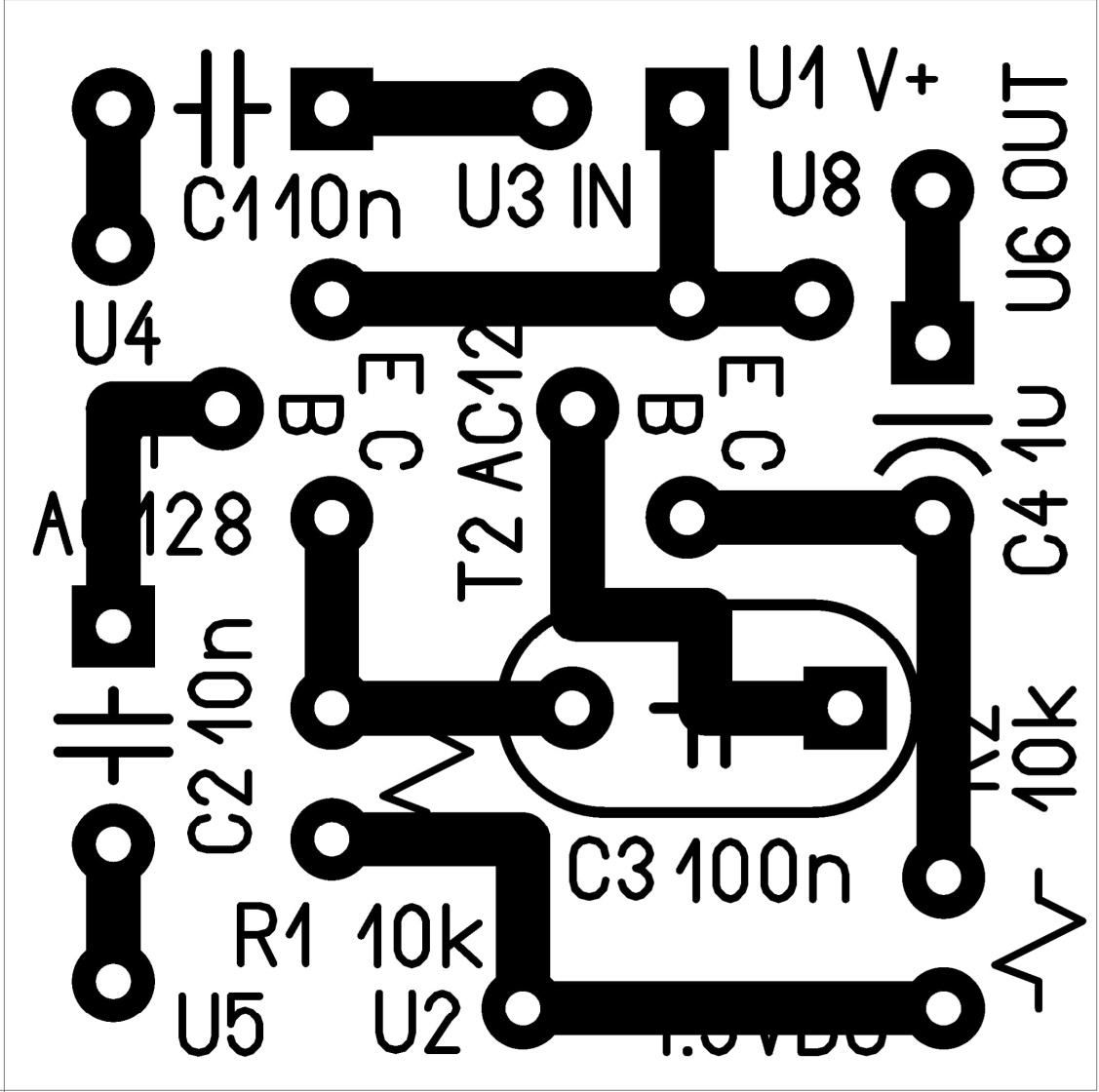

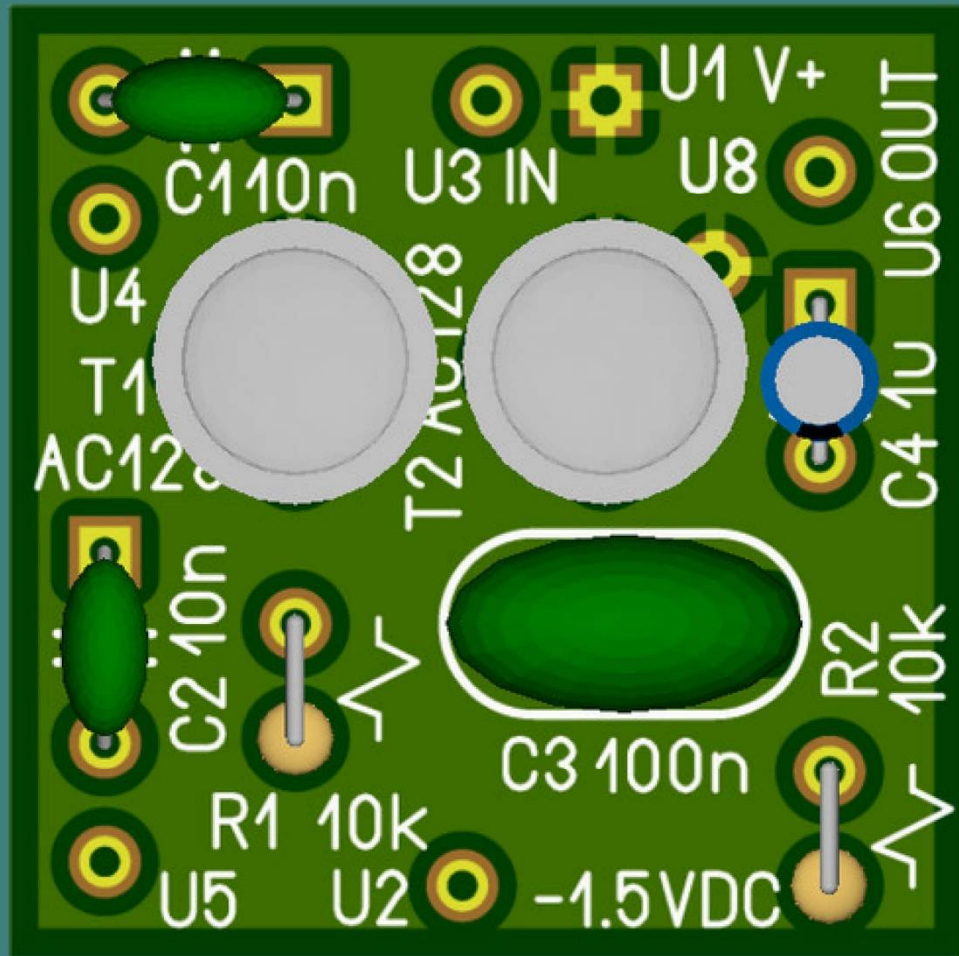

AAA Fuzz 2

AAA FUZZ 2 Schematic

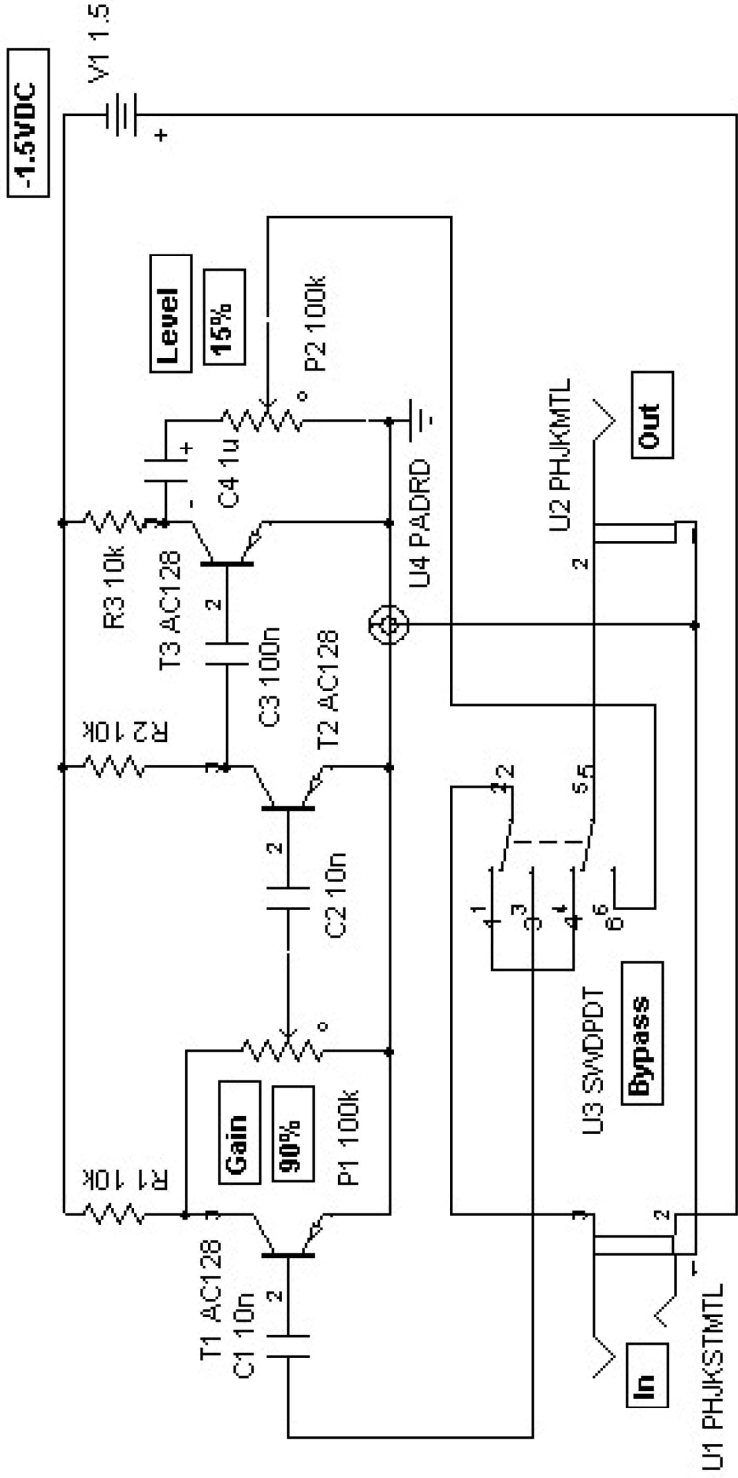

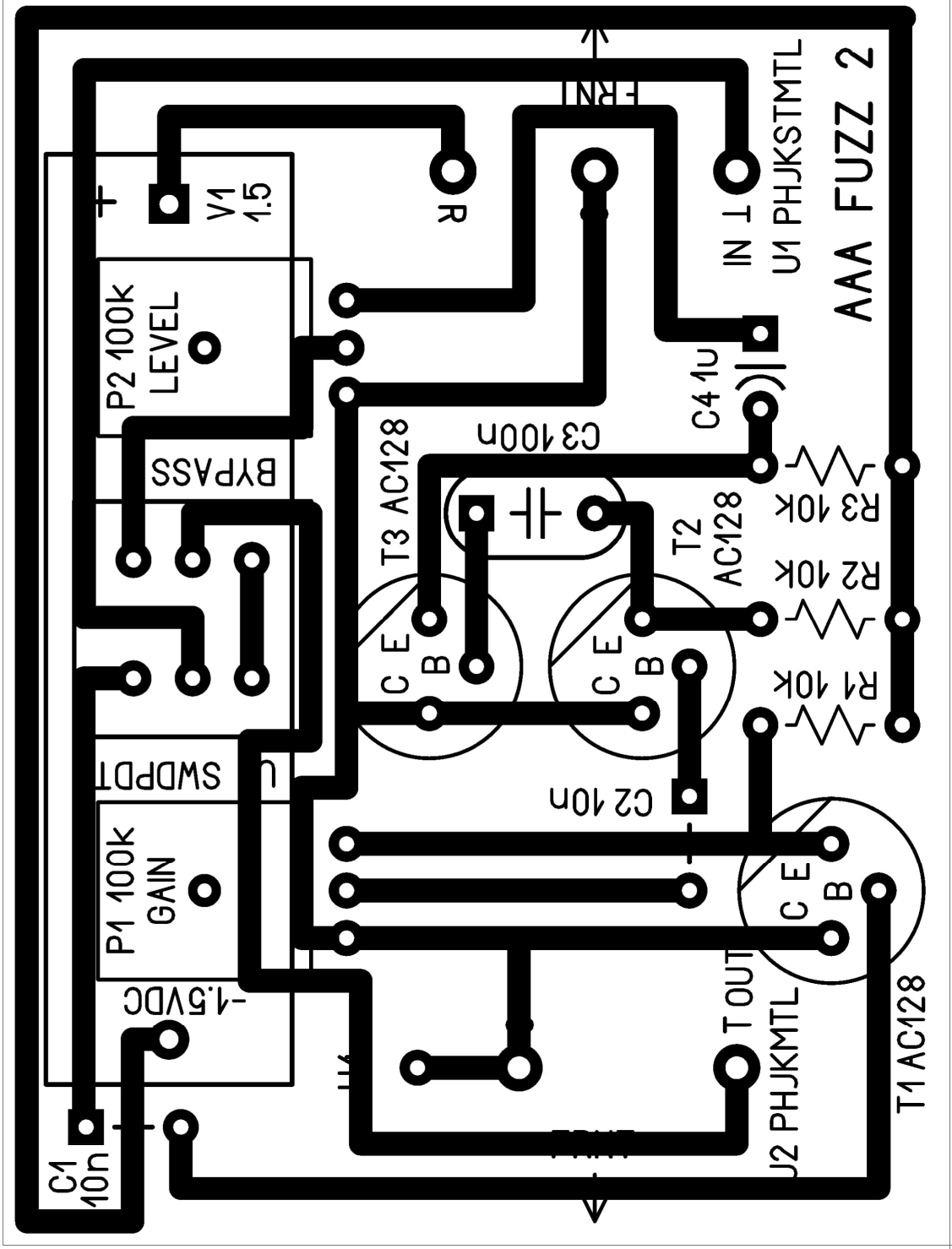

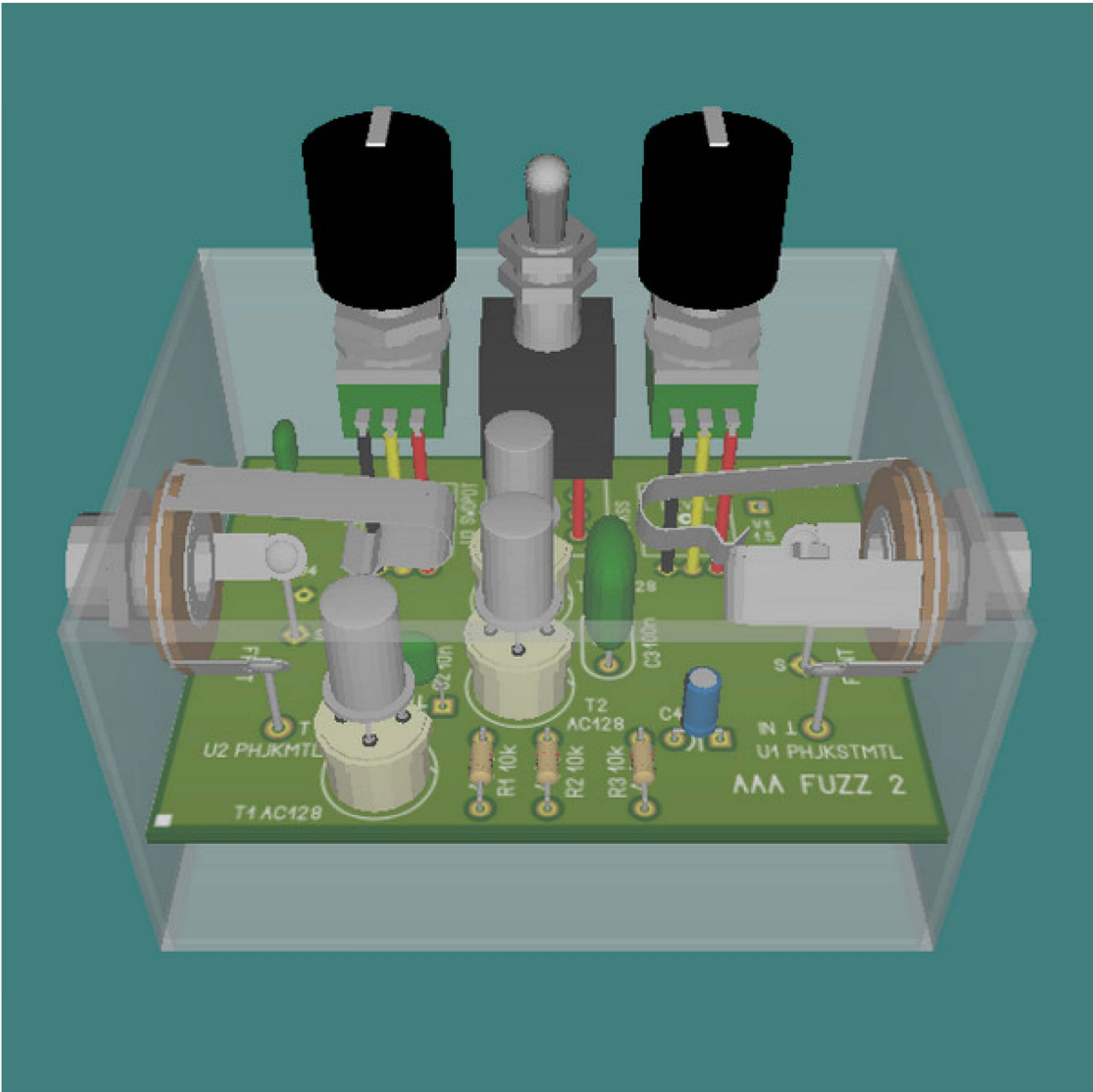

AAA Fuzz 2 BRD

AAA FUZZ 2 PC Board Schematic

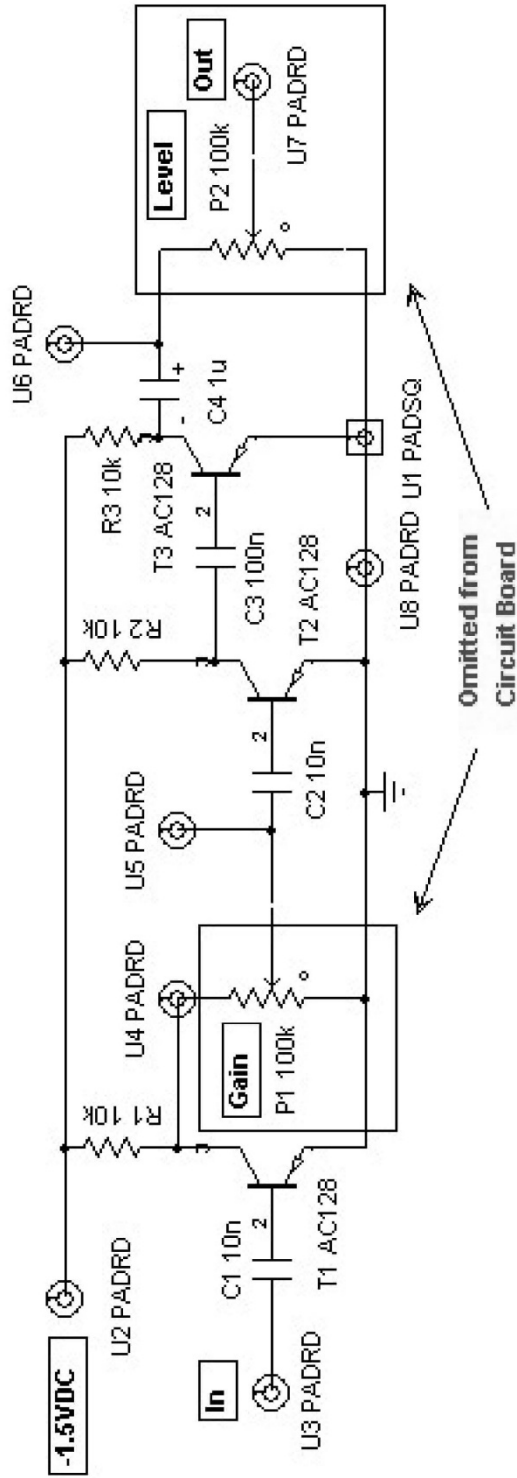

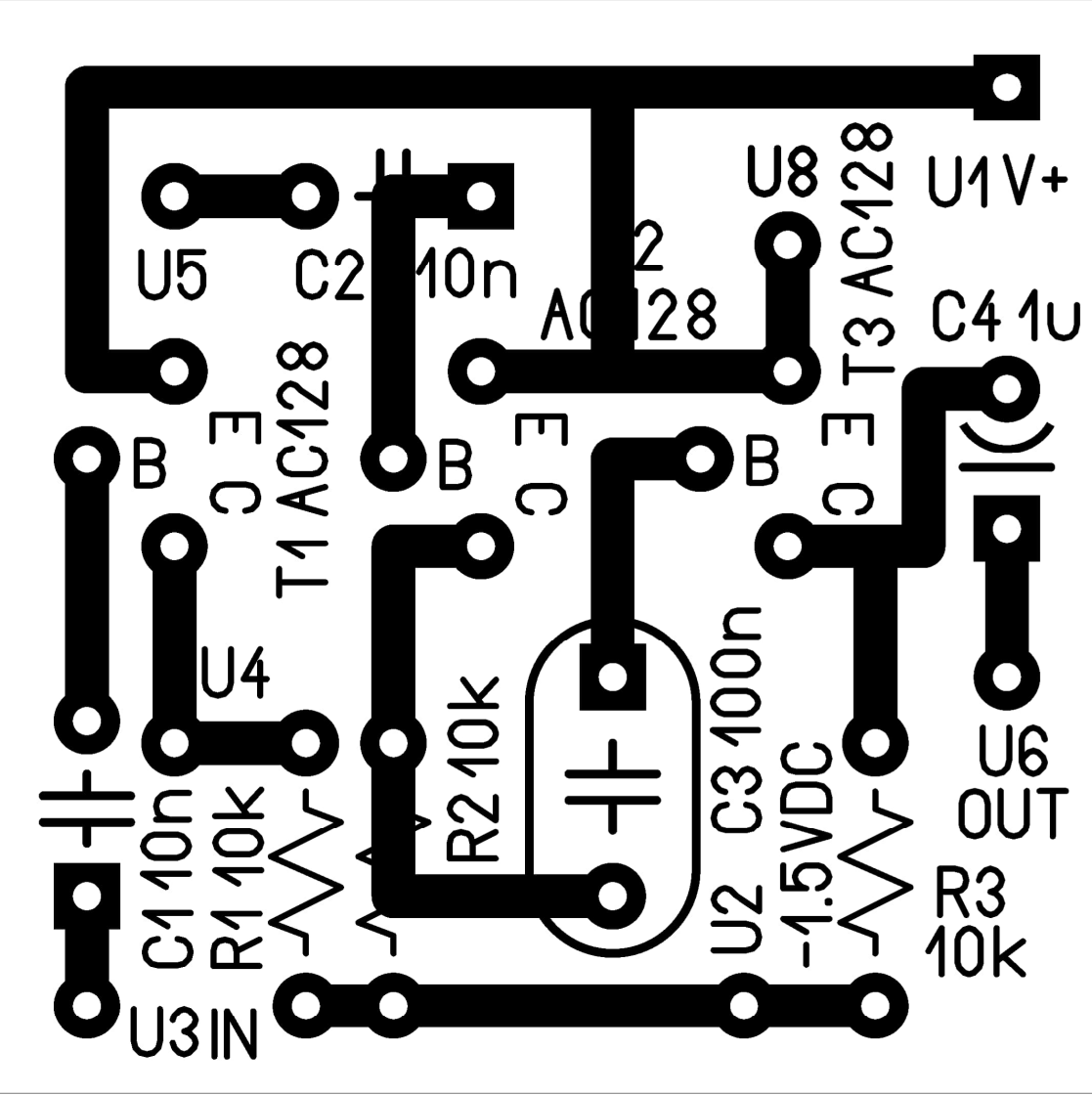

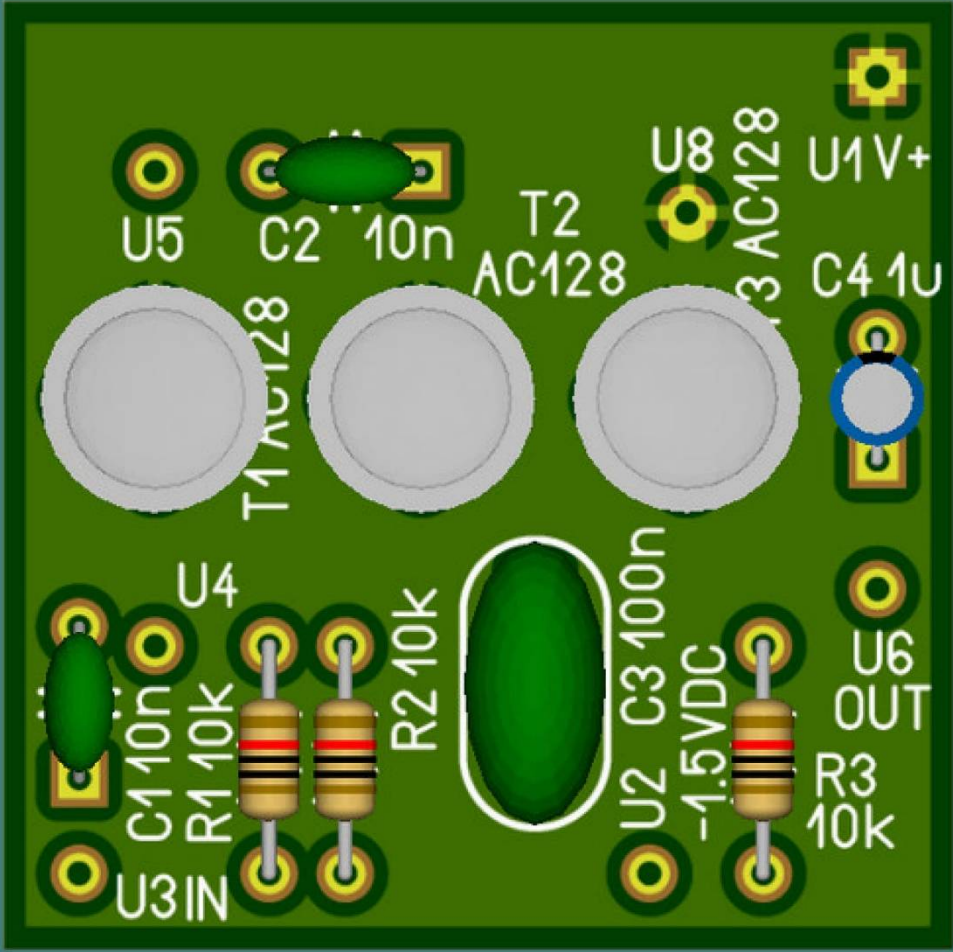

Vintage Guitar Fuzz 1

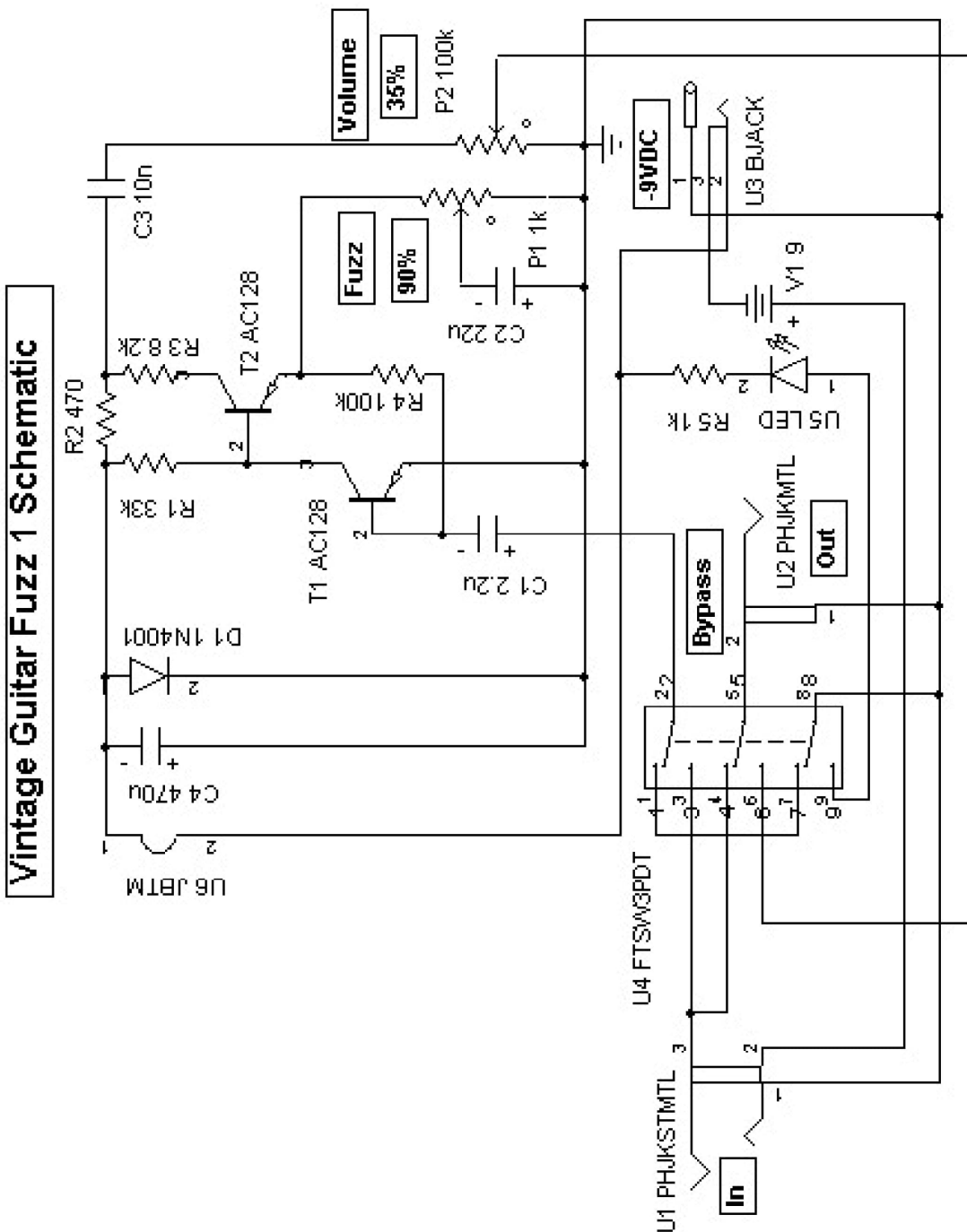

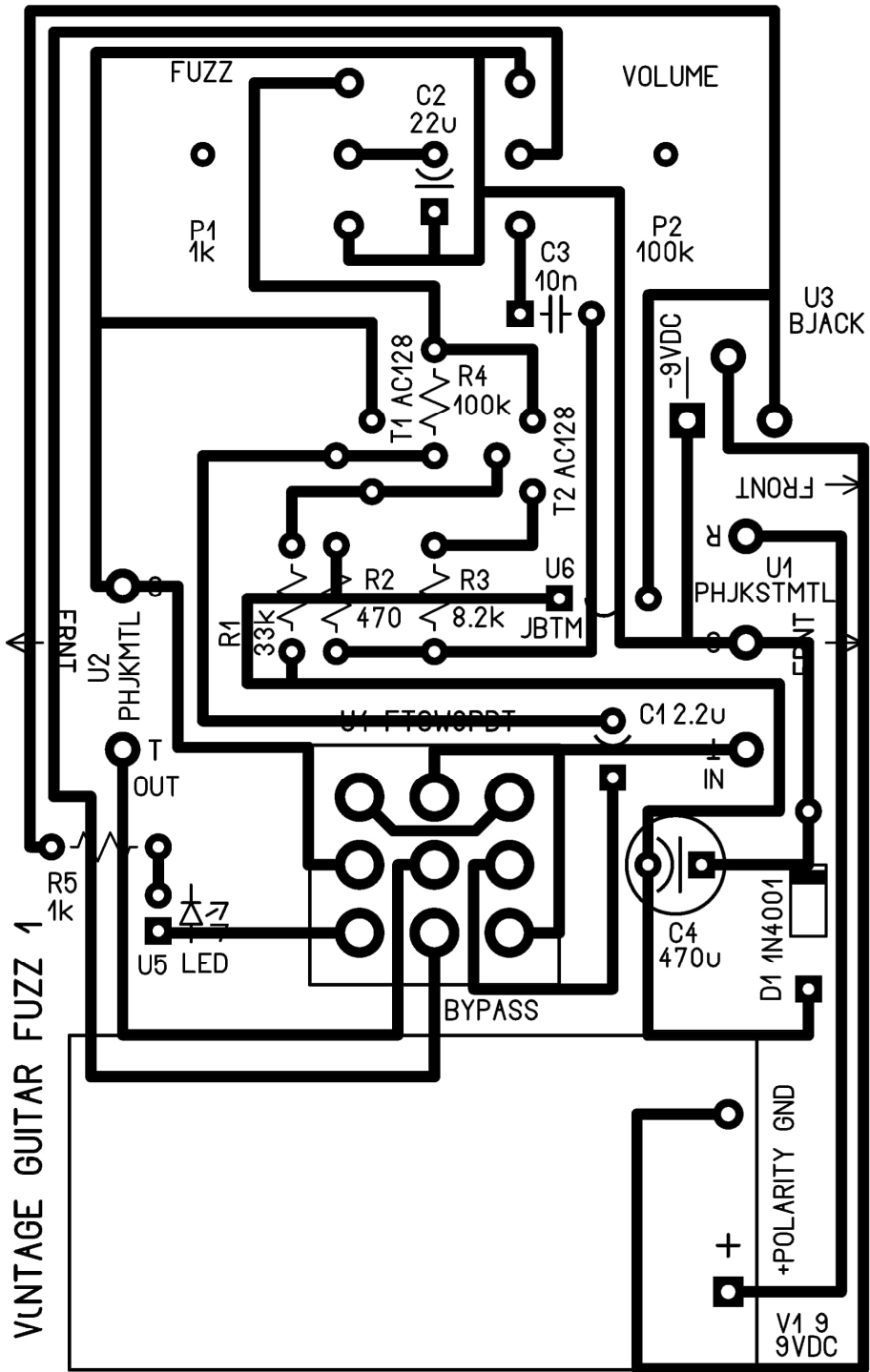

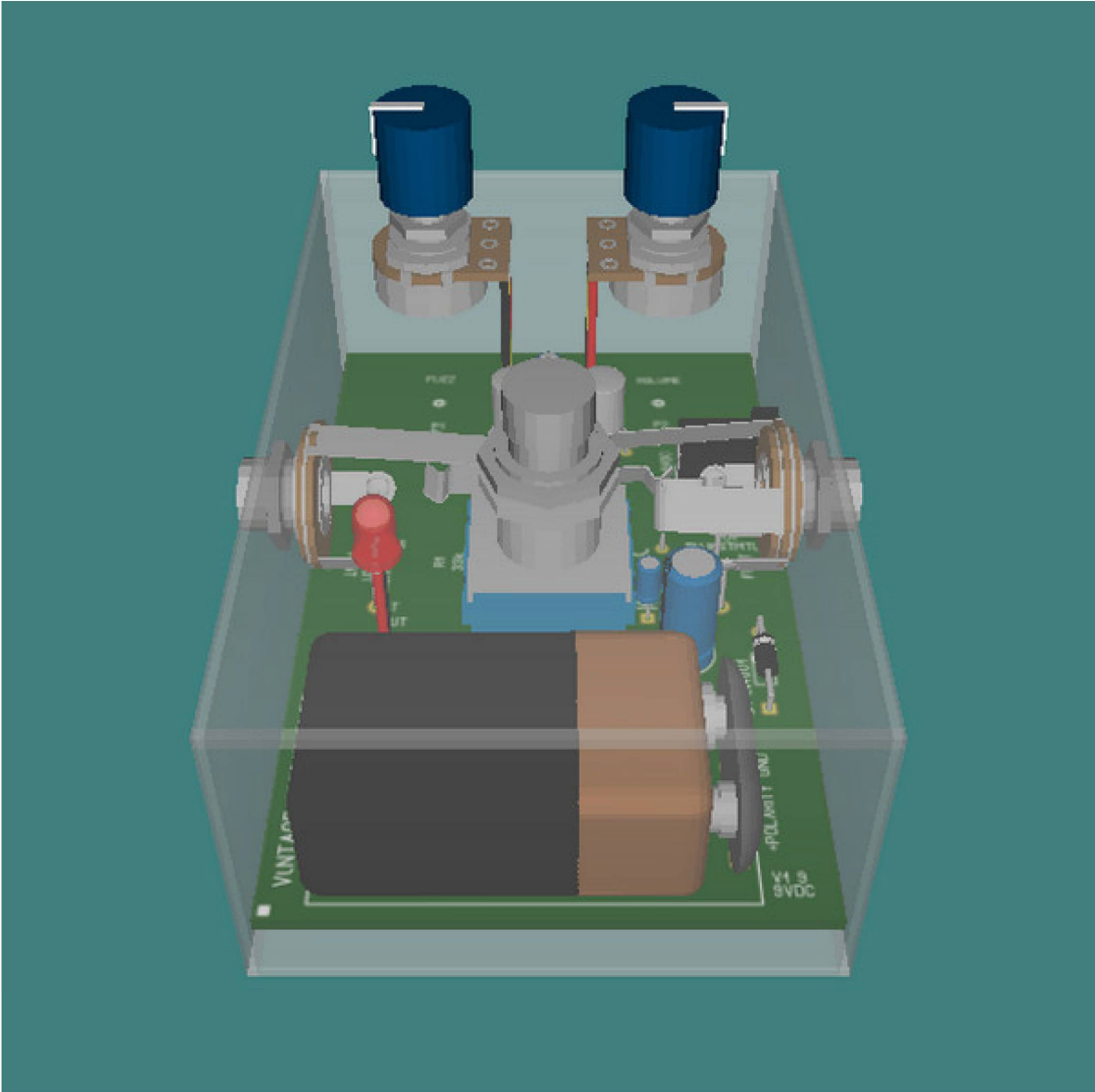

Vintage Guitar Fuzz 2

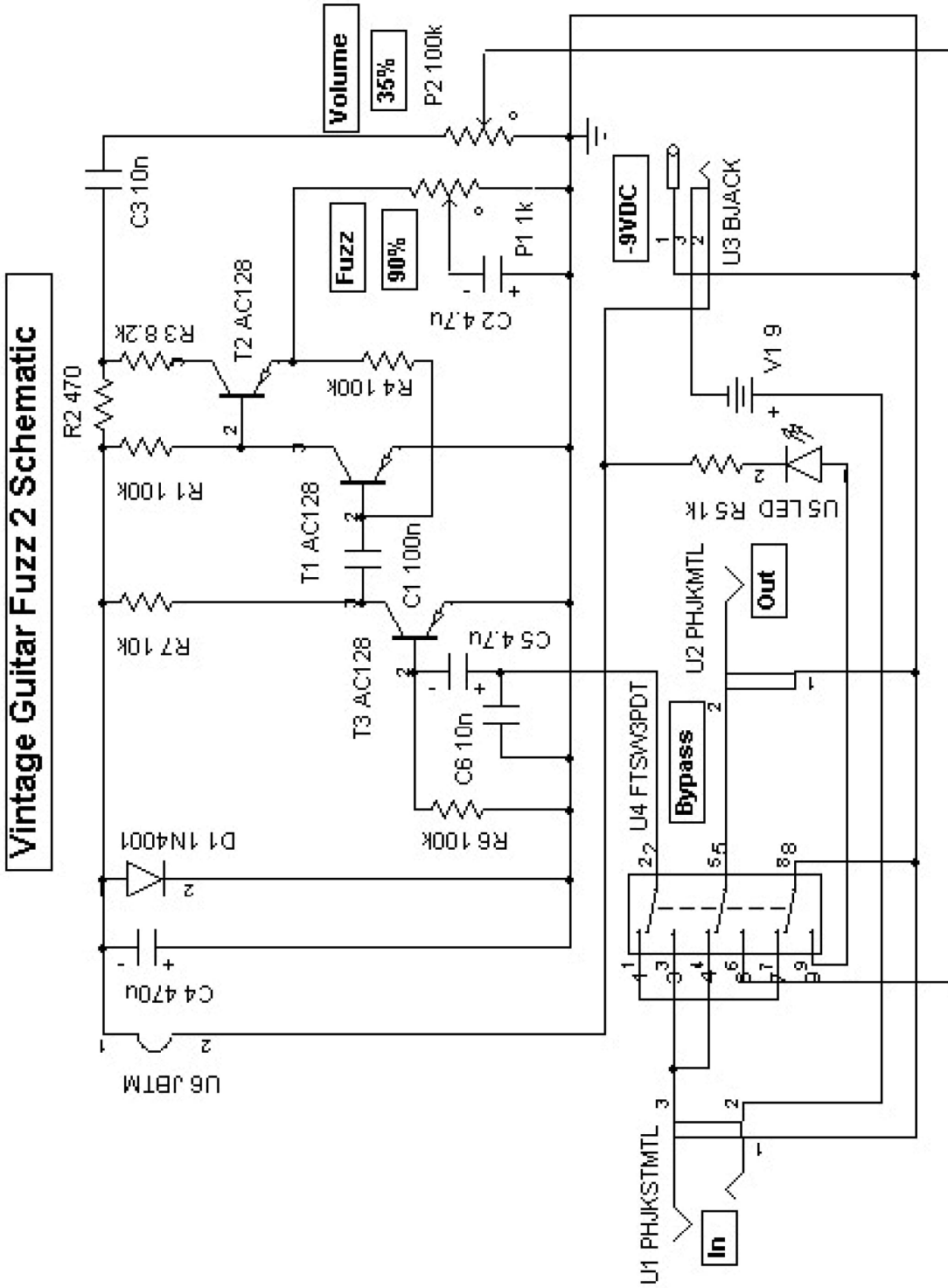

VINTAGE GUITAR FUZZ 2

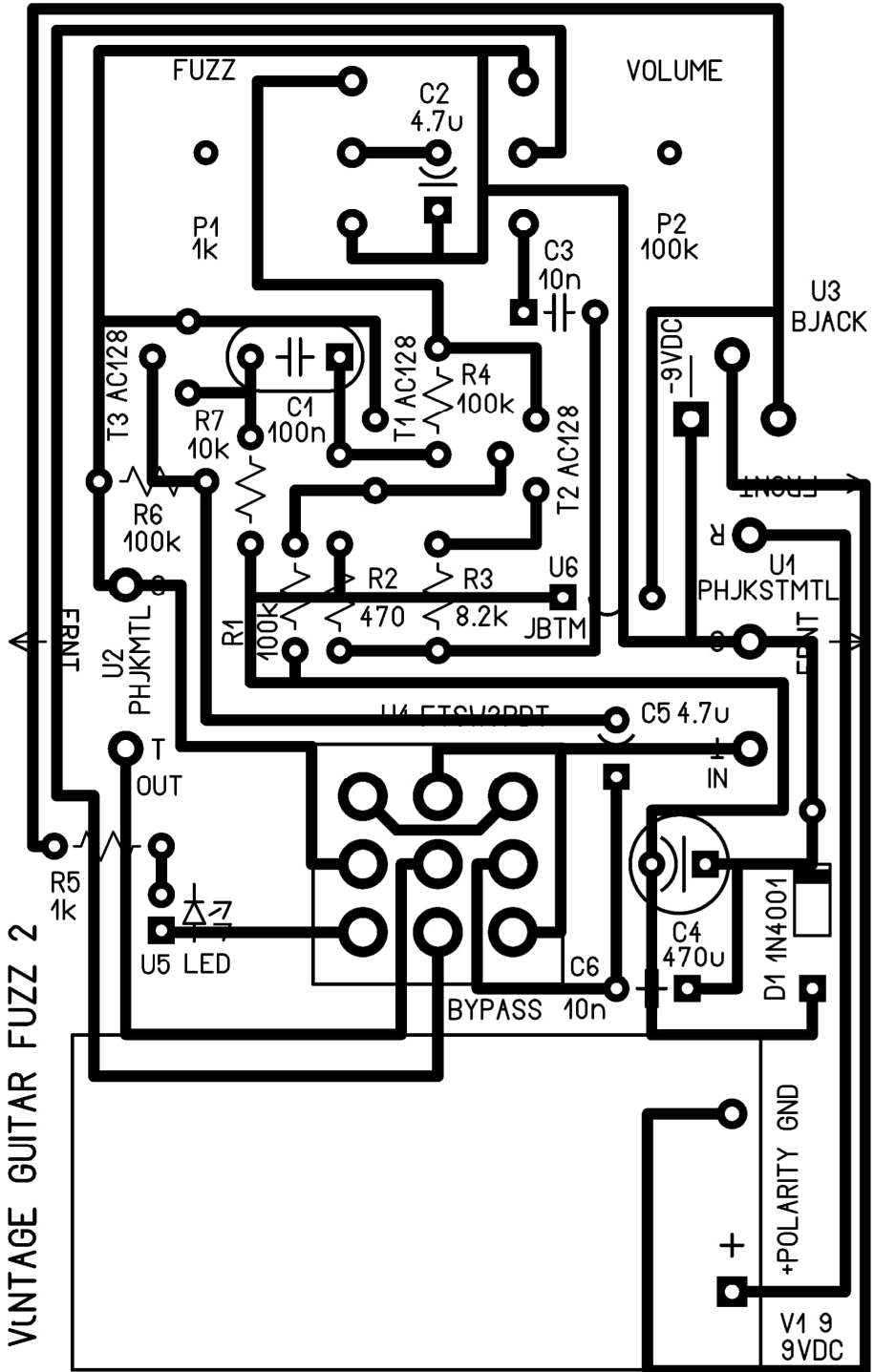

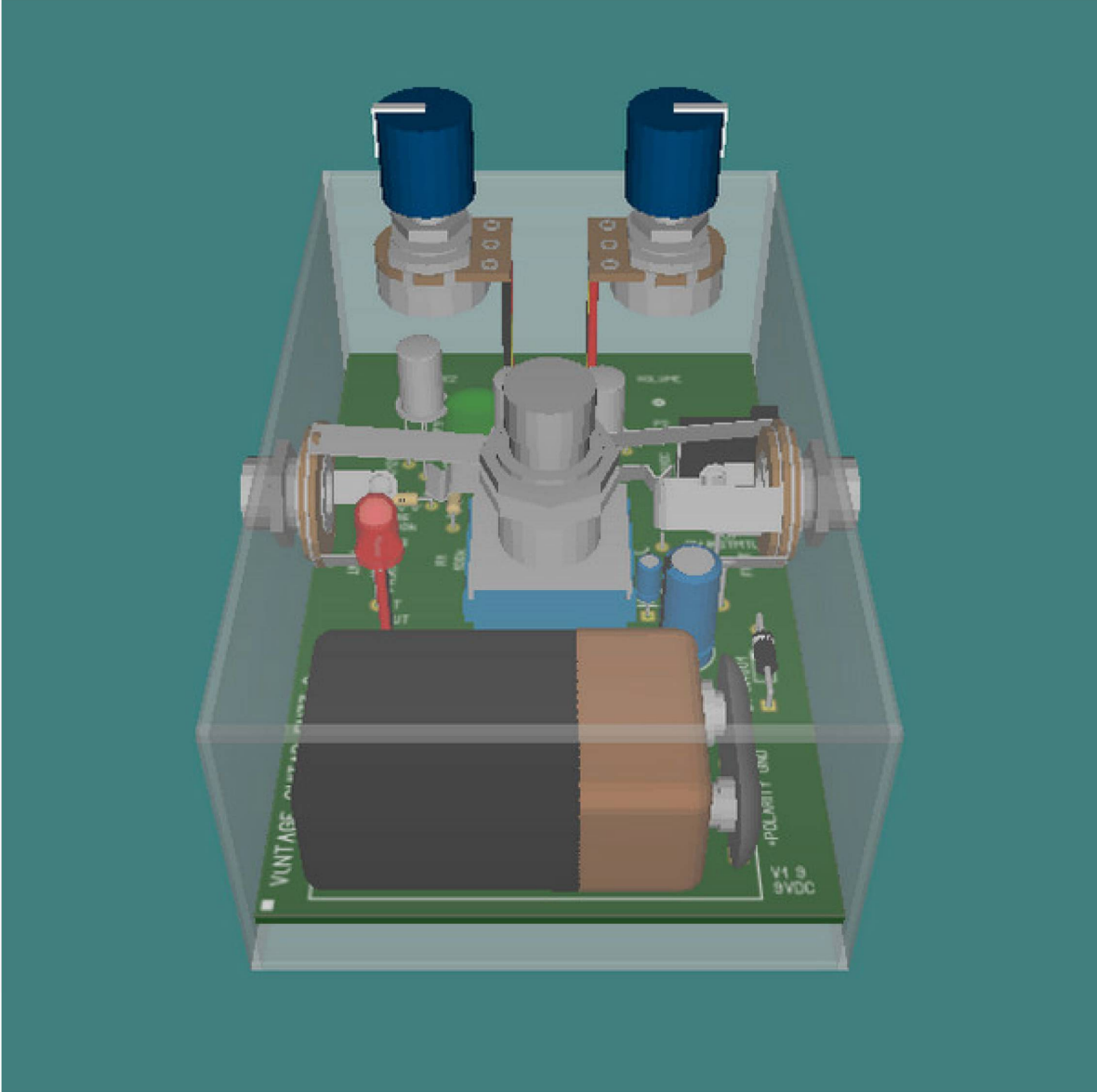

Vintage Guitar Fuzz (Basic)

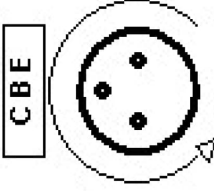
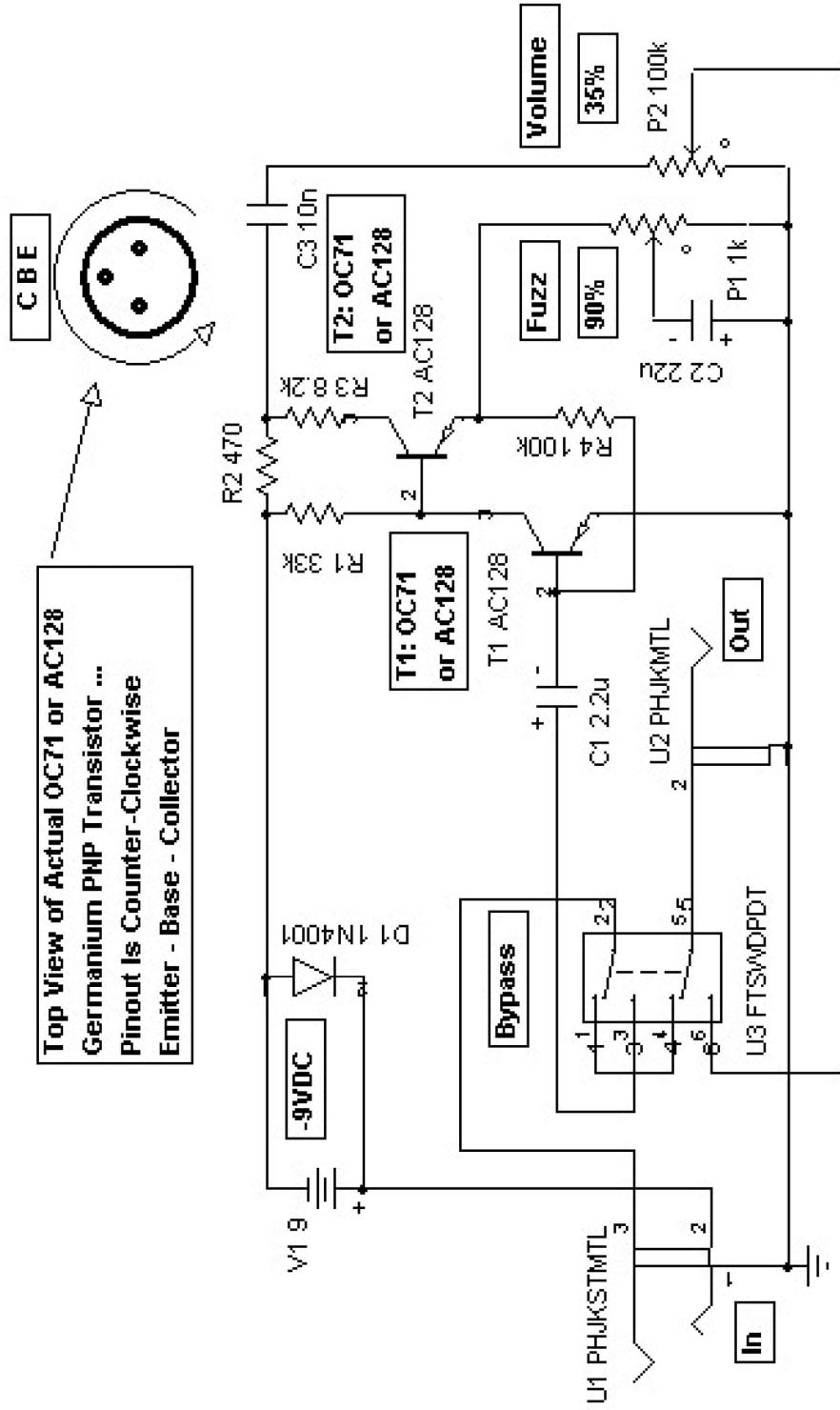

Top View of Actual OC71 or AC128
 Germanium PNP Transistor ...
 Pinout Is Counter-Clockwise
 Emitter - Base - Collector

Vintage Guitar Fuzz (Basic) Schematic

VINTAGE GUITAR FUZZ BASIC

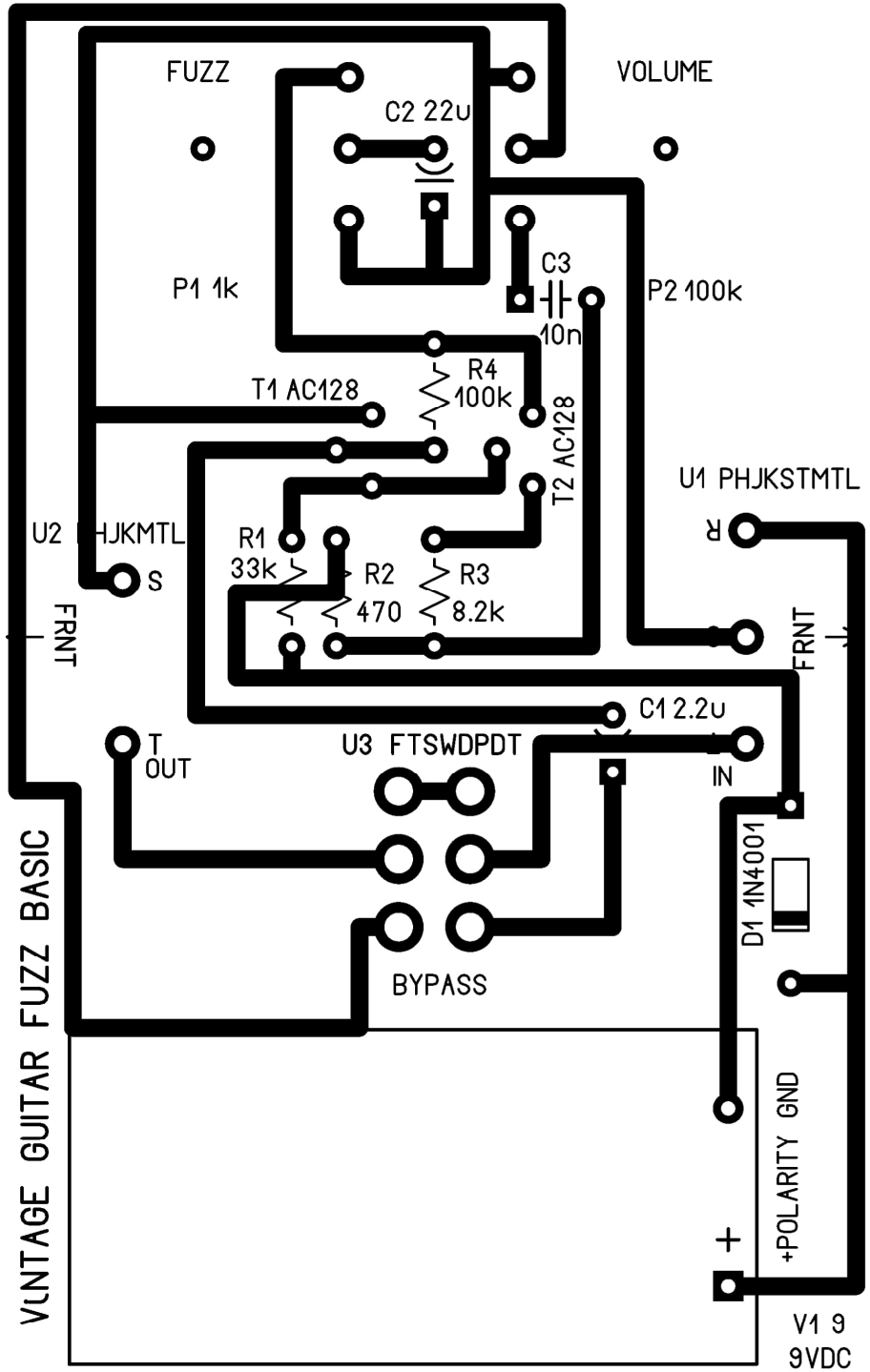

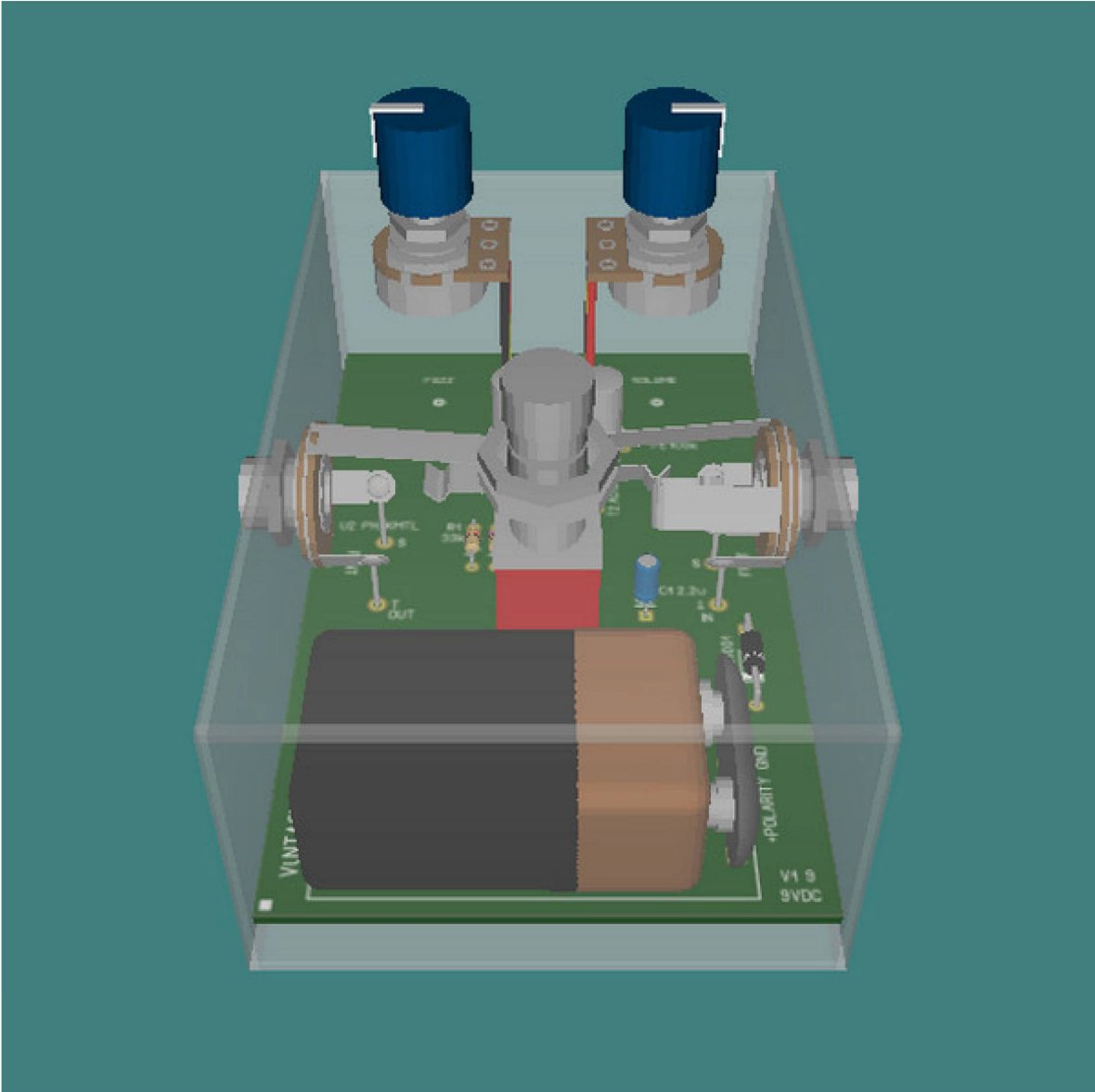

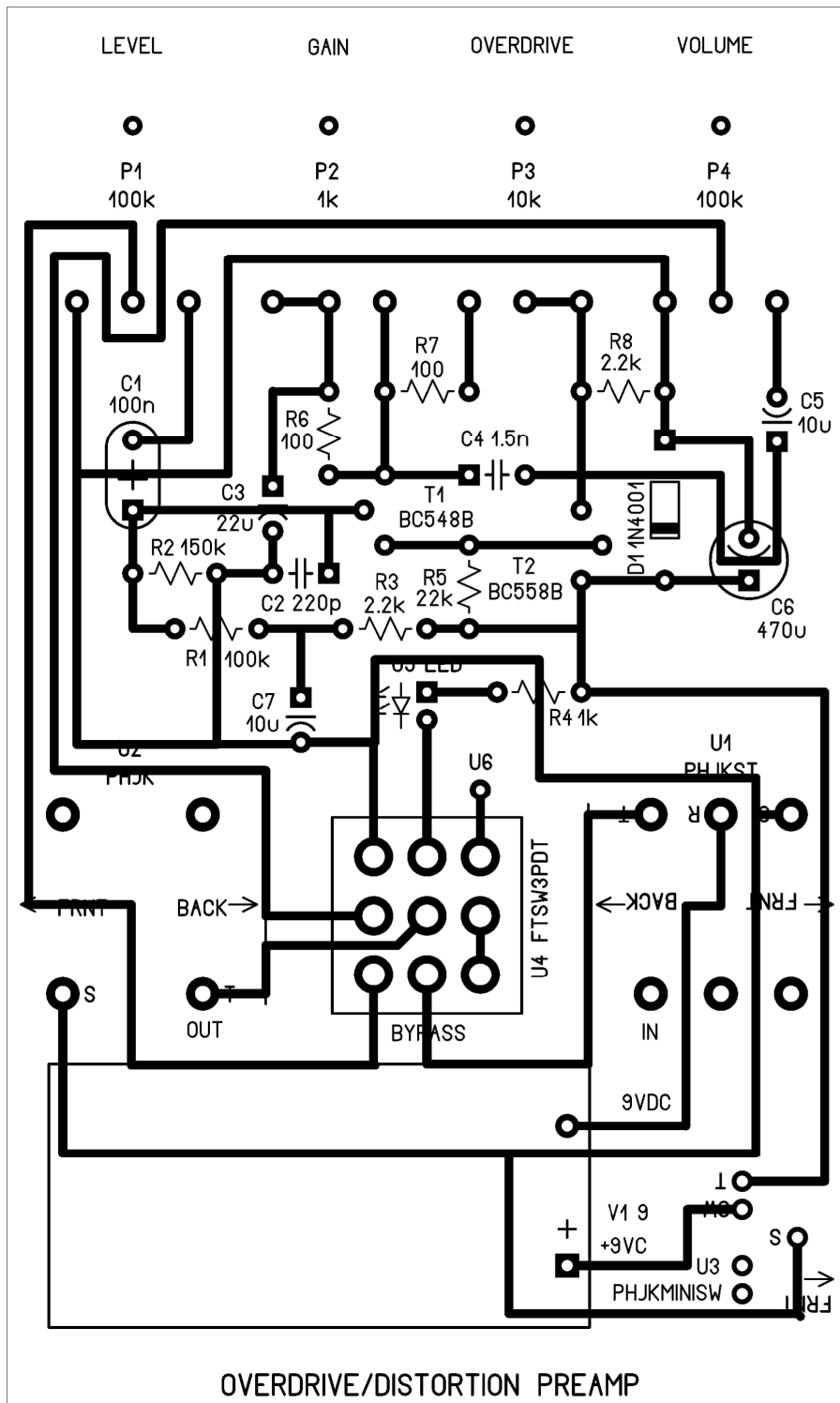

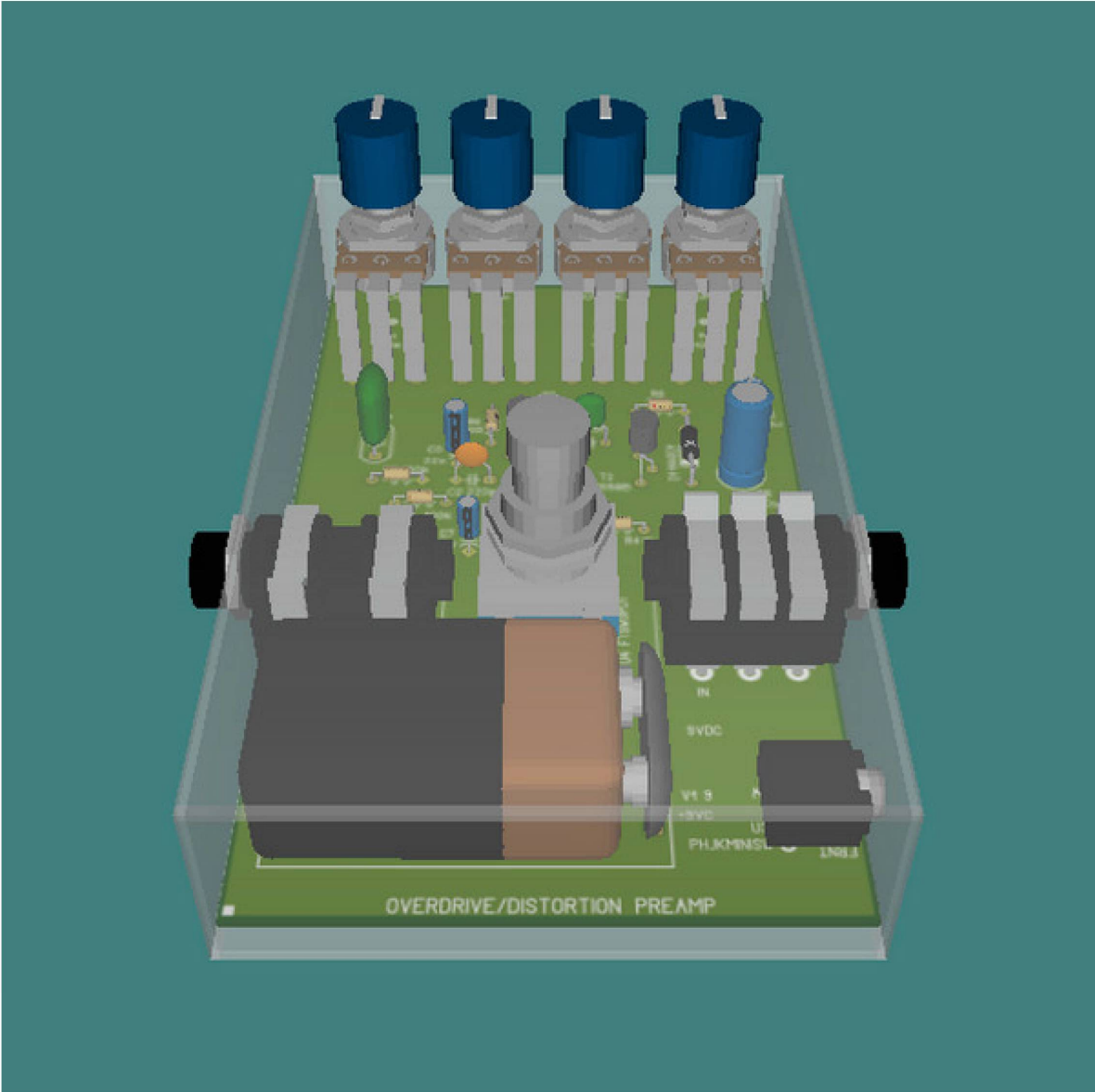

Electric Guitar Distortion Effect

Electric Guitar Distortion Effect Schematic

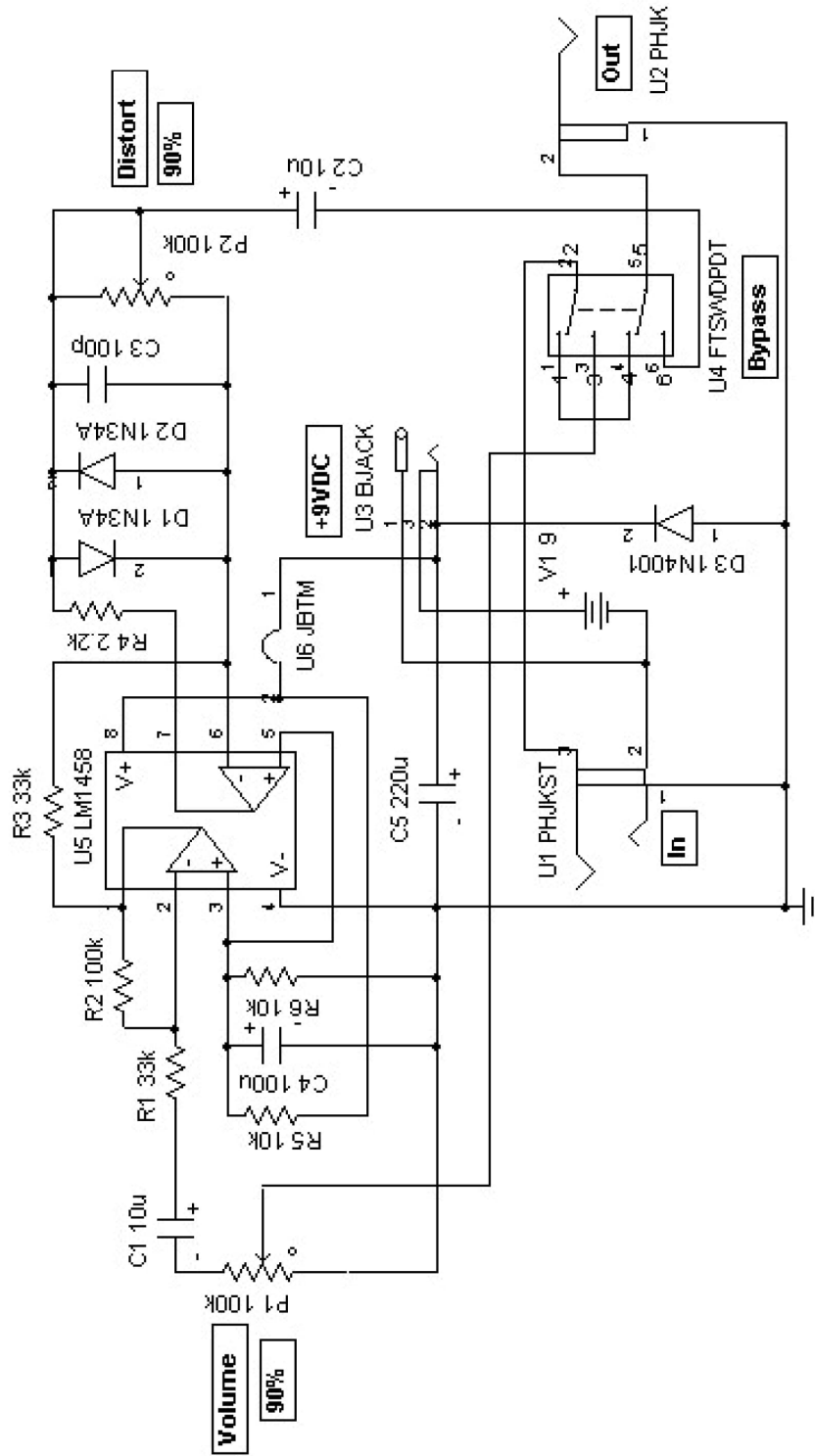

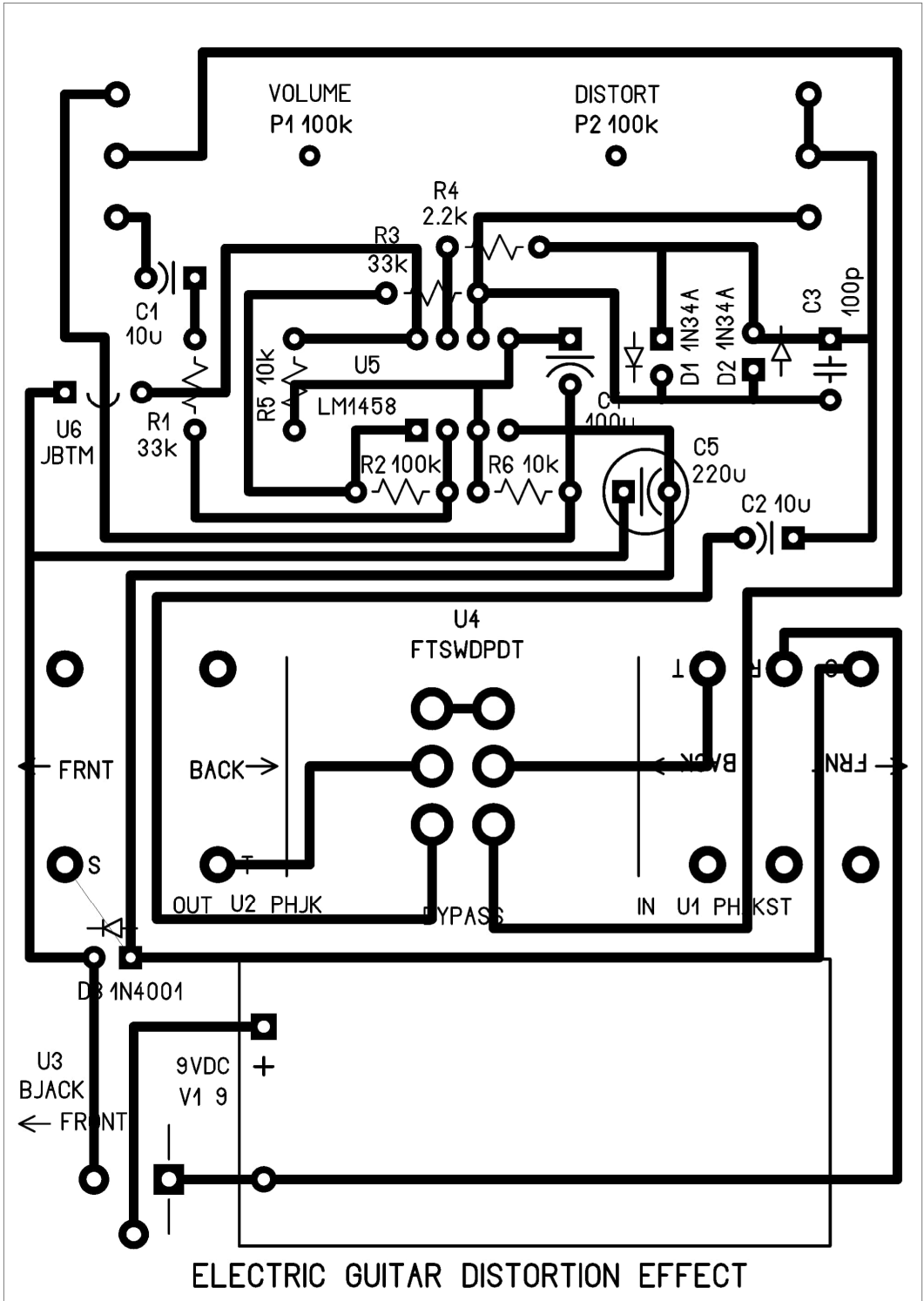

ELECTRIC GUITAR DISTORTION EFFECT

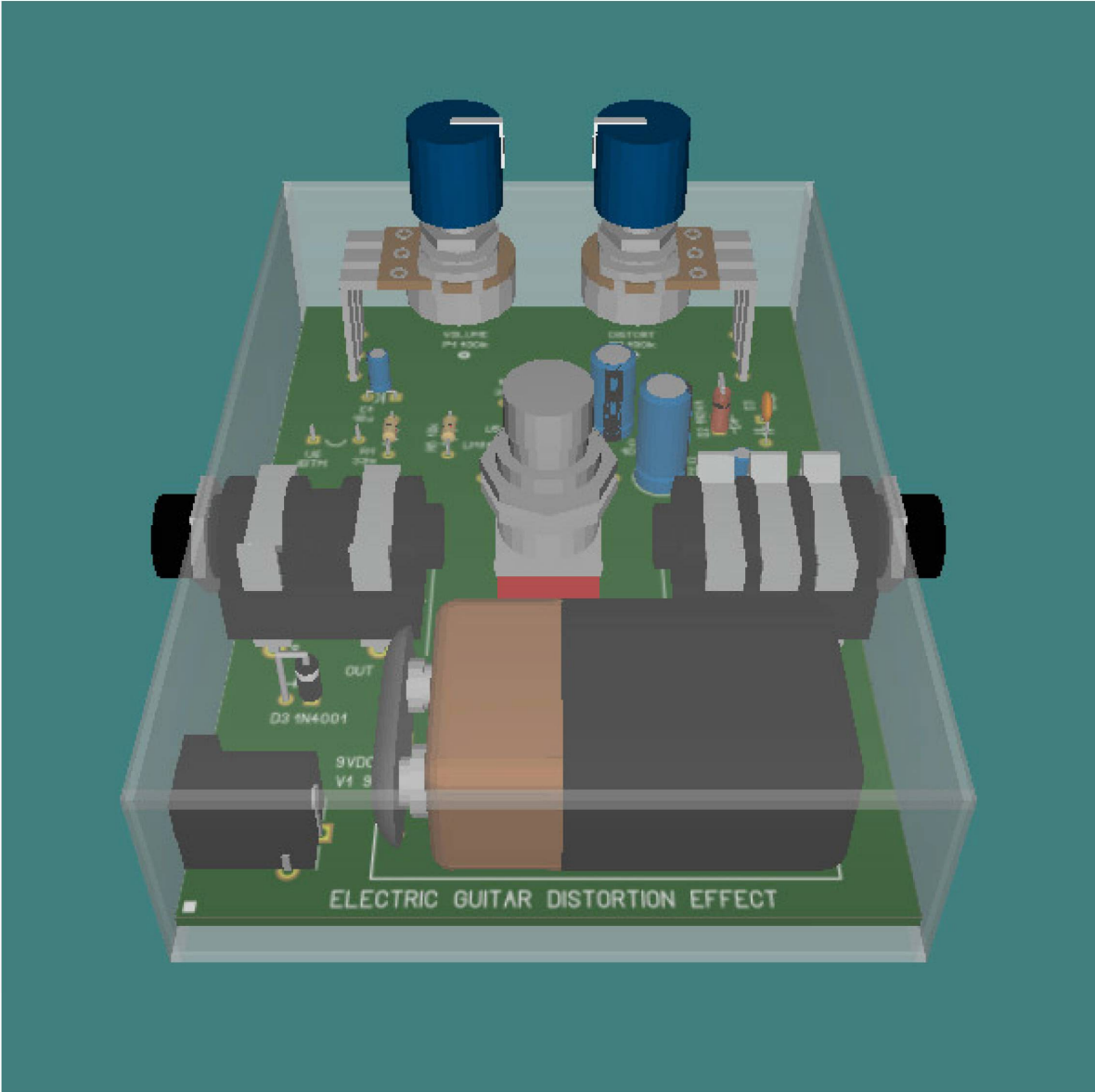

Z-Overdrive

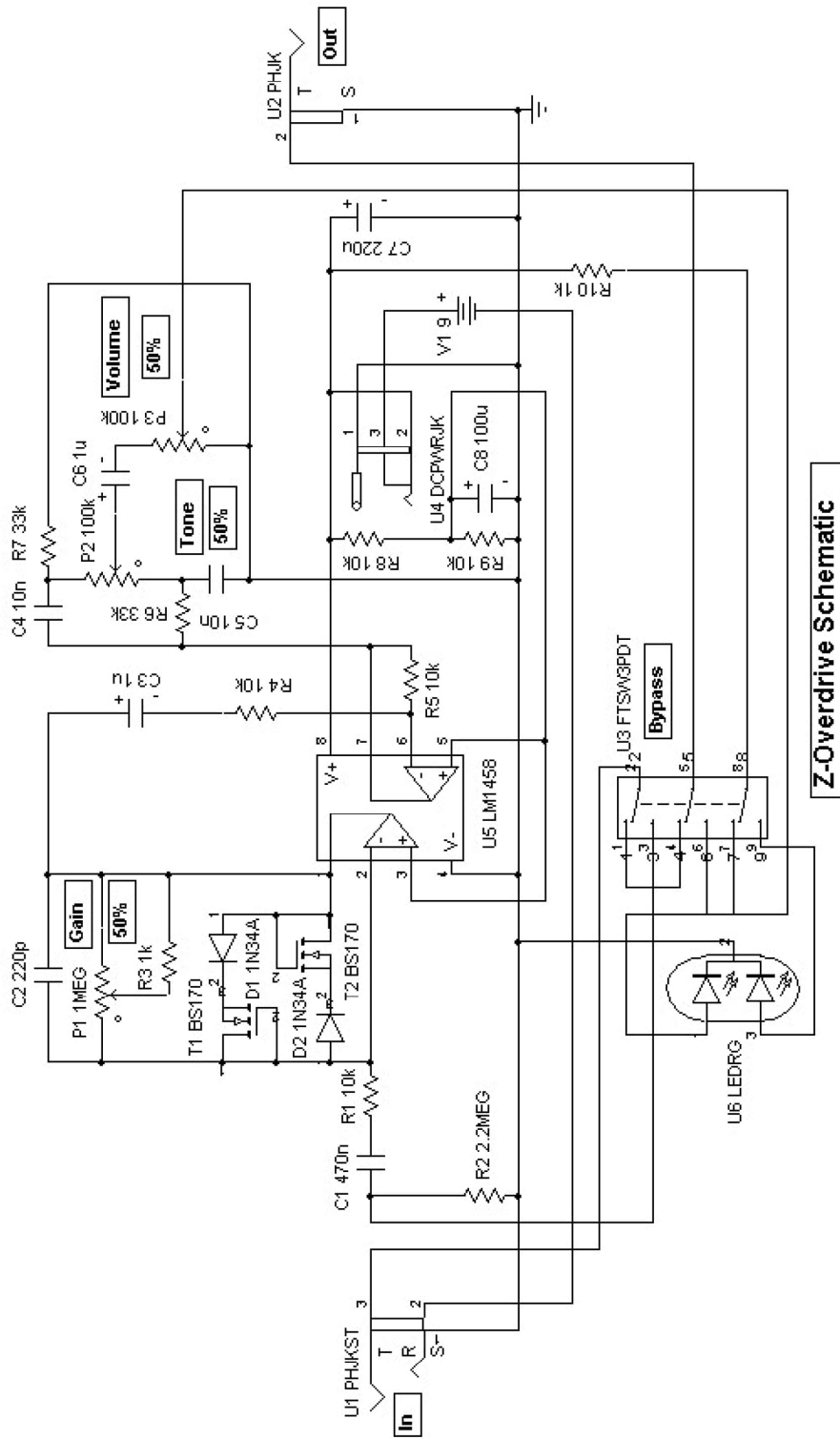

Z-Overdrive Schematic

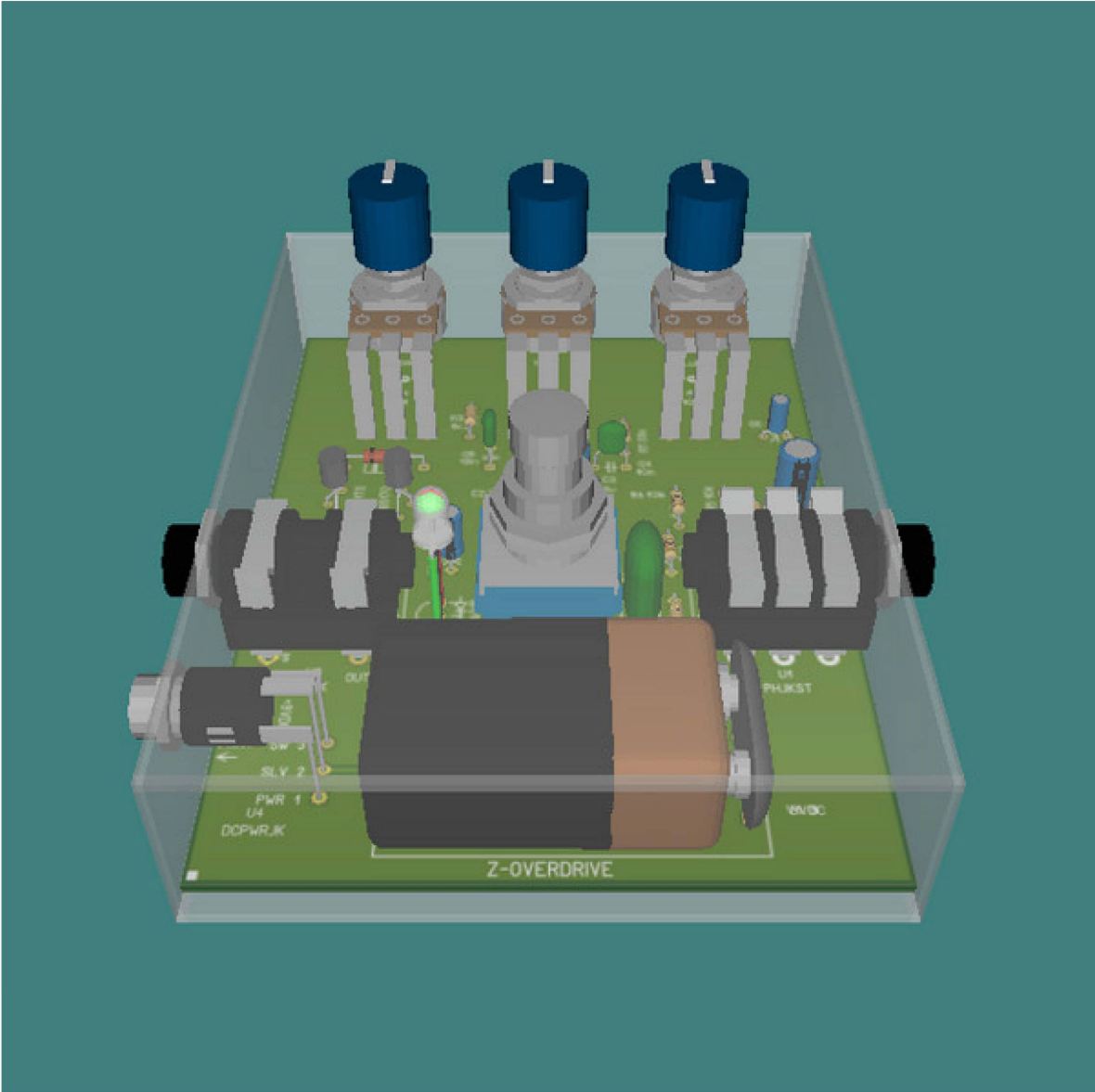

NPN Transistors Fuzz Effect

NPN Transistors Fuzz Effect Schematic

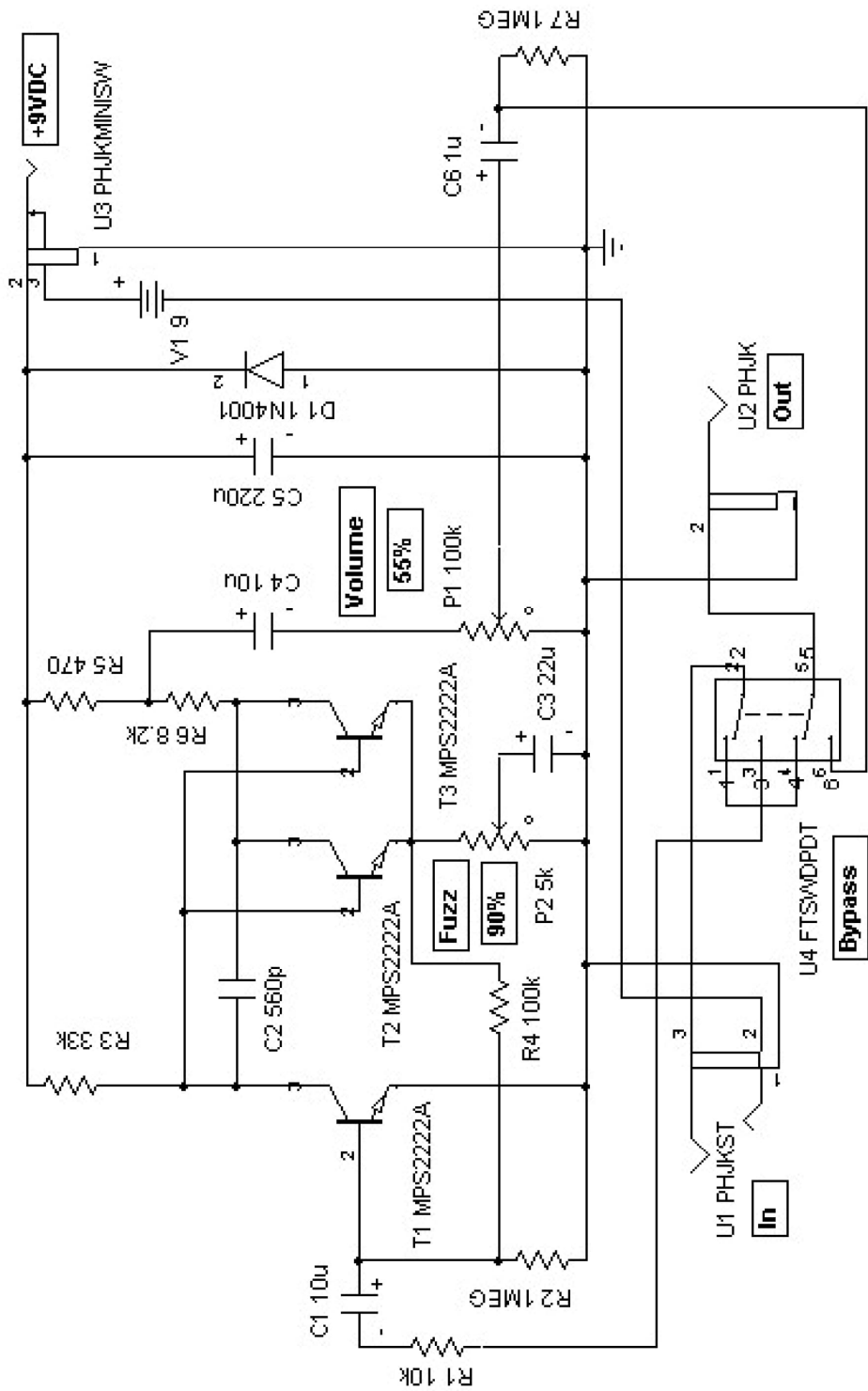

VOLUME

FUZZ

P1
100k

P2
5k

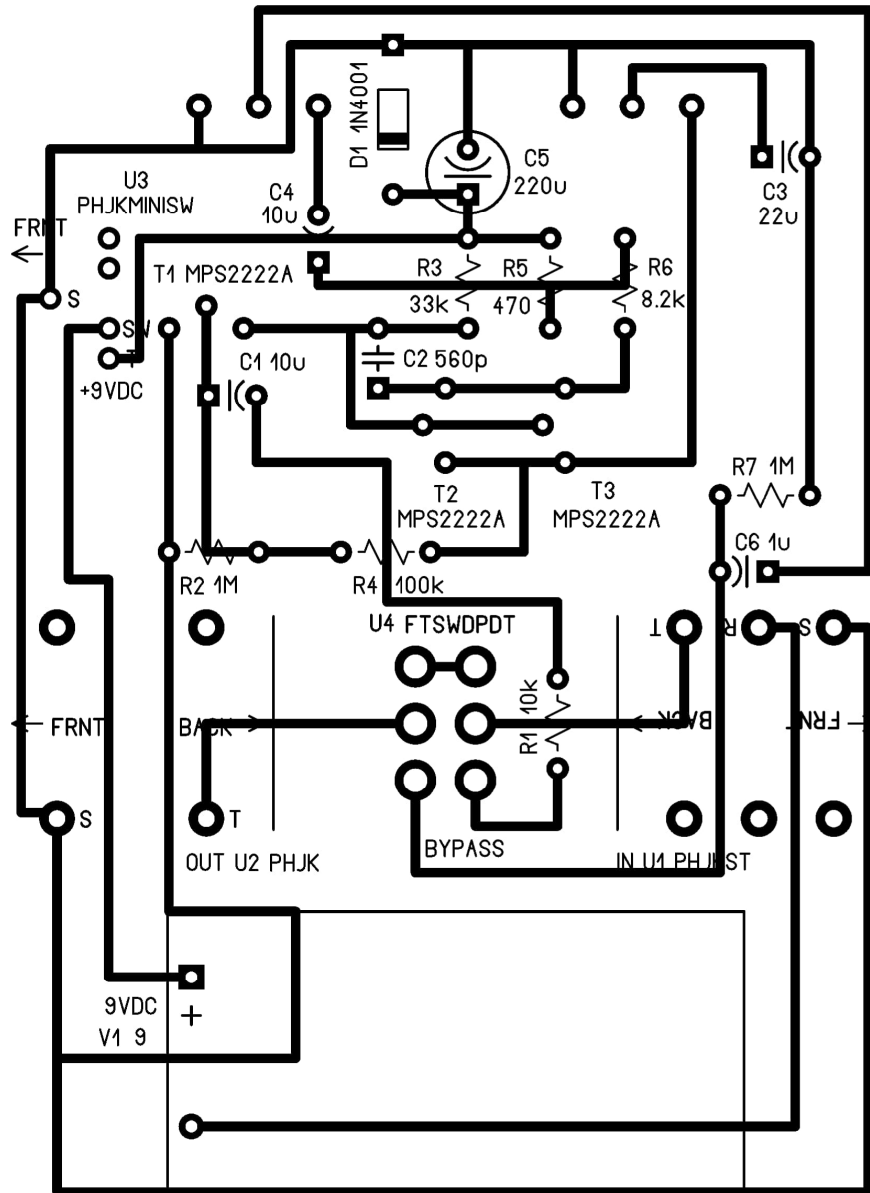

NPN TRANSISTORS FUZZ EFFECT

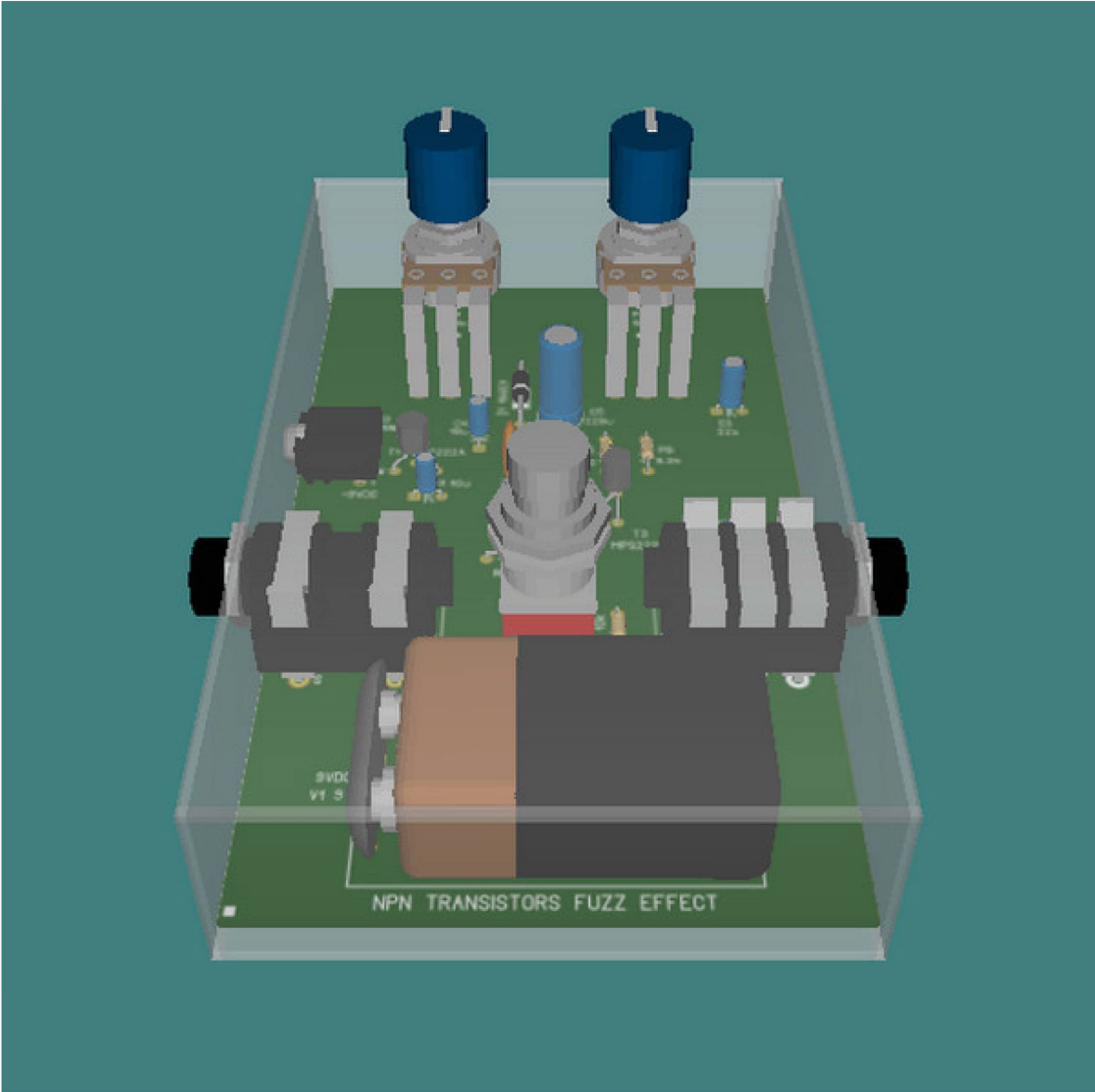

LM741-LM386 Overdrive/Distortion Effect

LM741-LM386 Overdrive/Distortion Effect Schematic

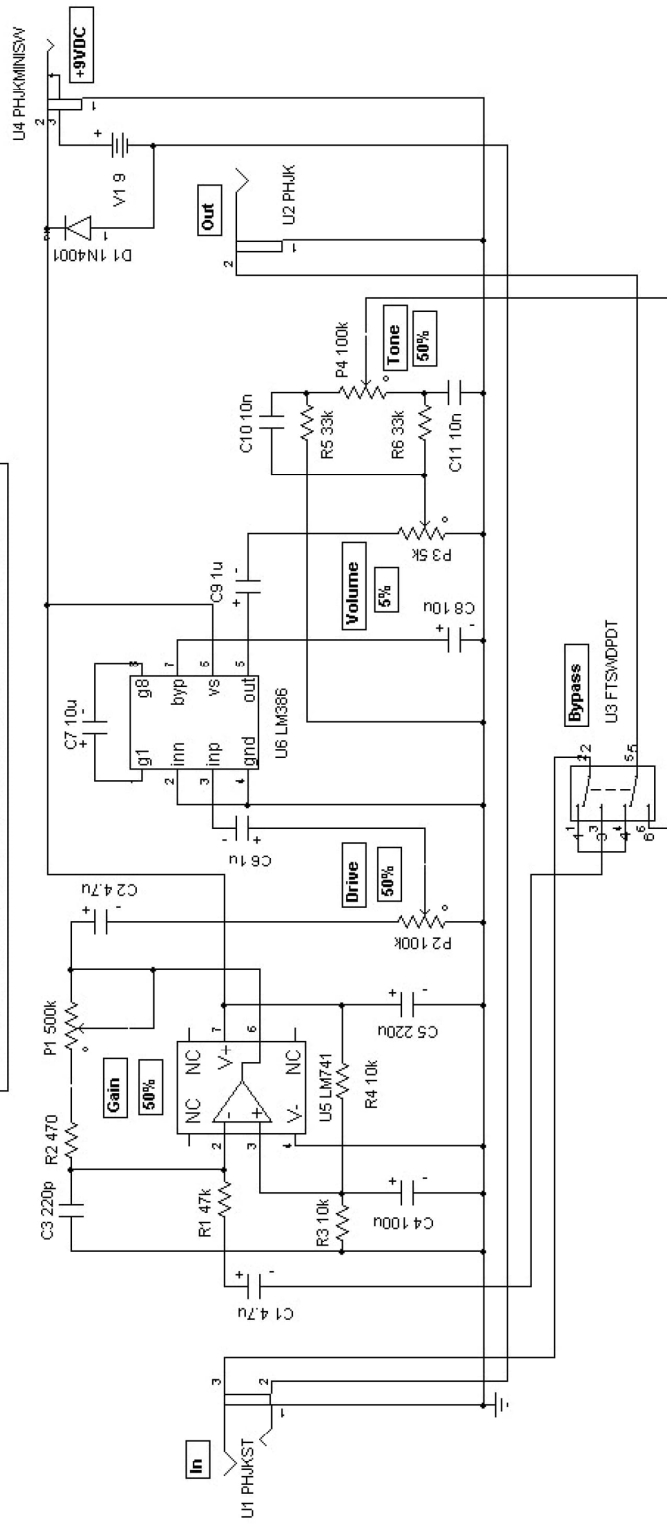

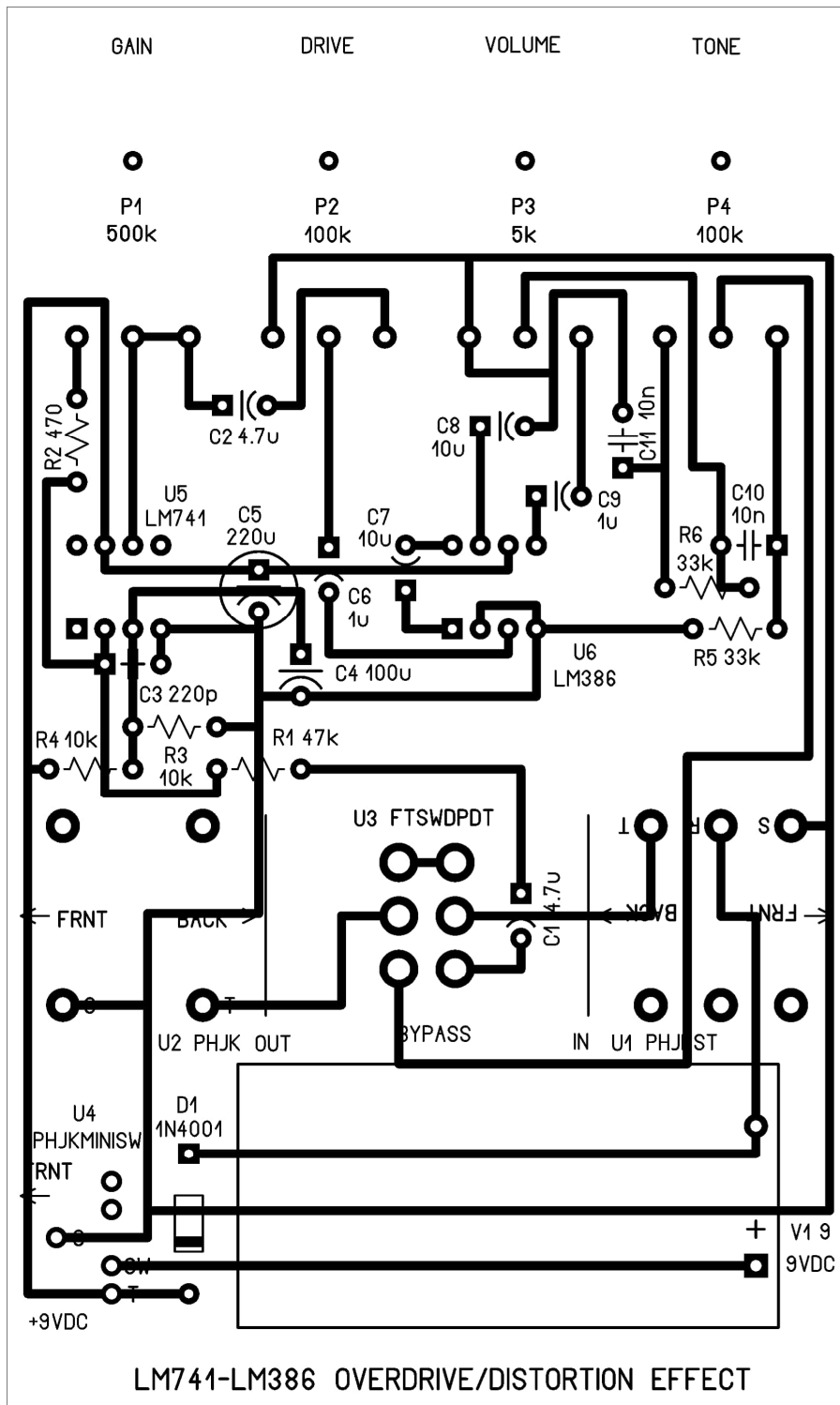

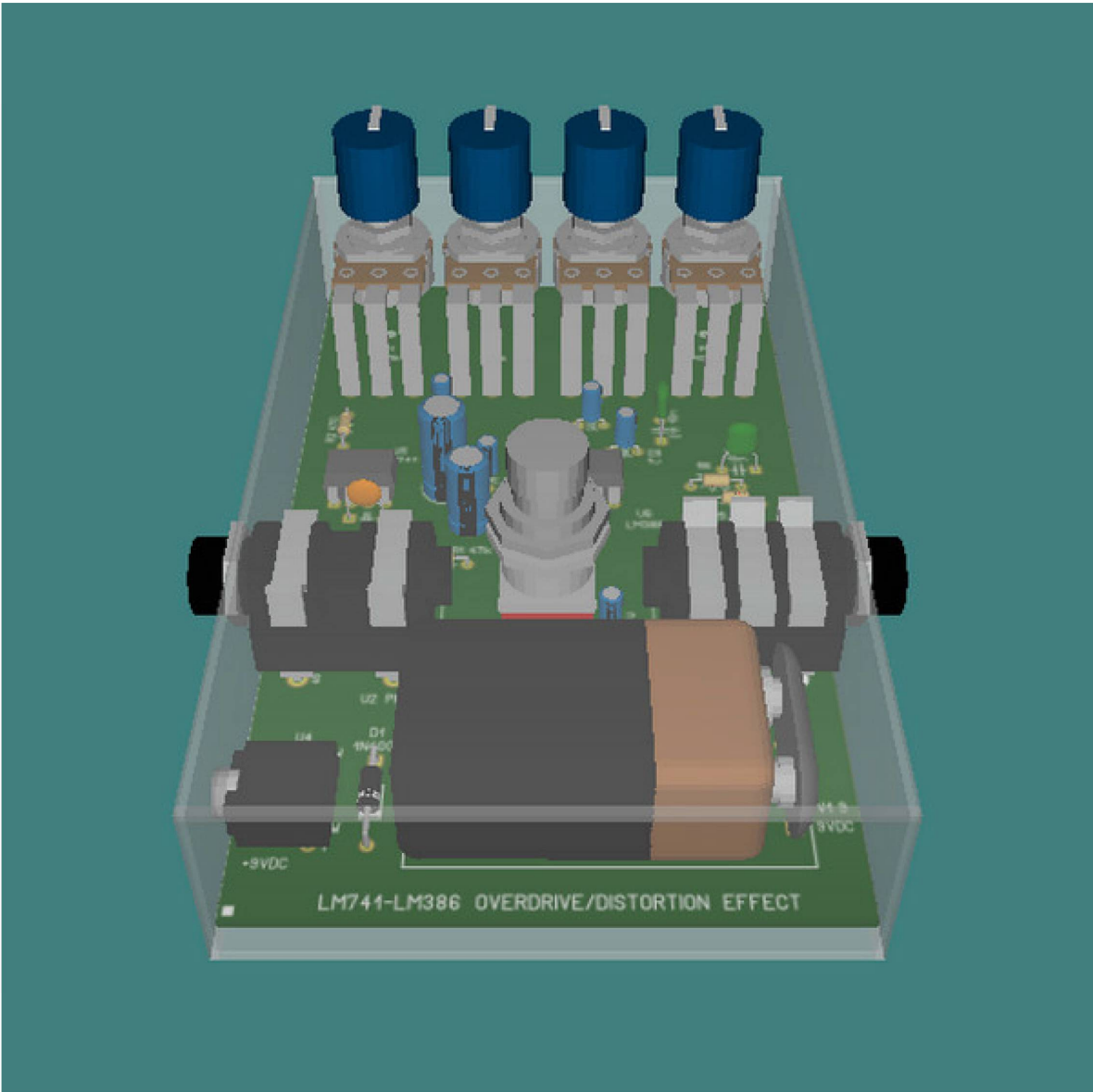

LM741-LM386 Overdrive/Fuzz Effect

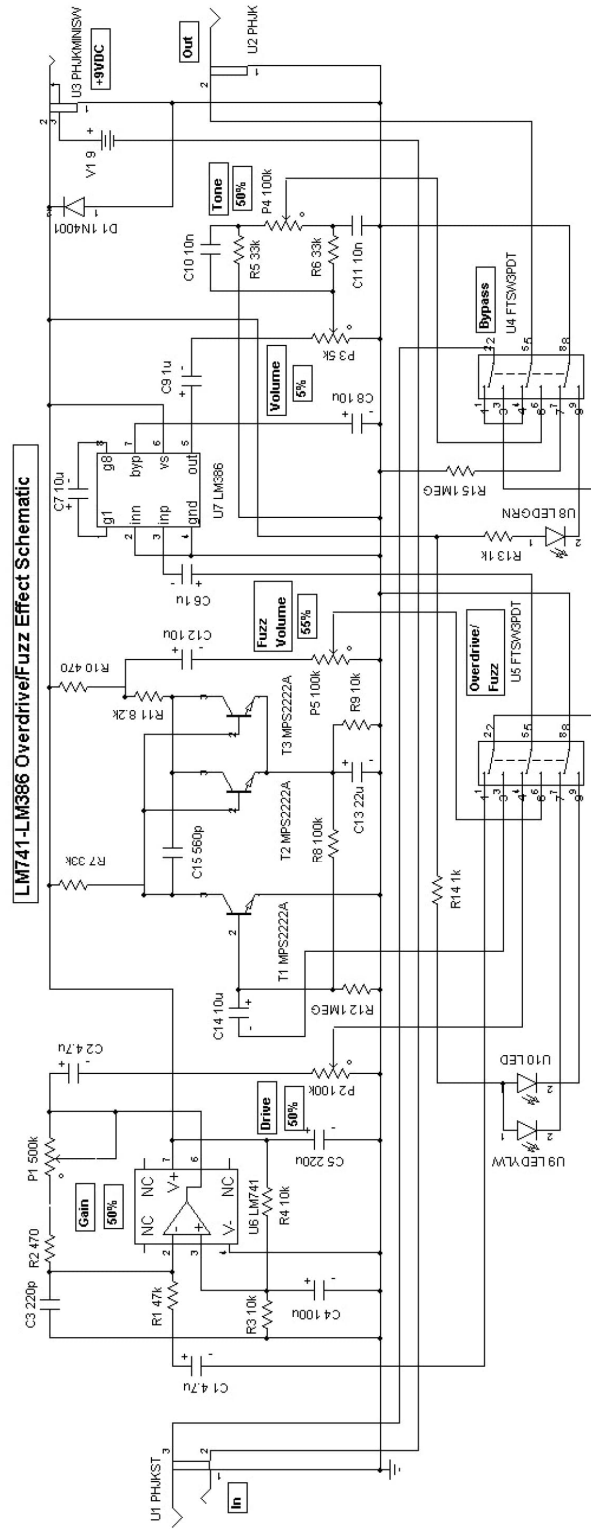

GAIN
P1
500k

DRIVE
P2
100k

VOLUME
P3
5k

STONE
P4
100k

FUZZ VOLUME
P5
100k

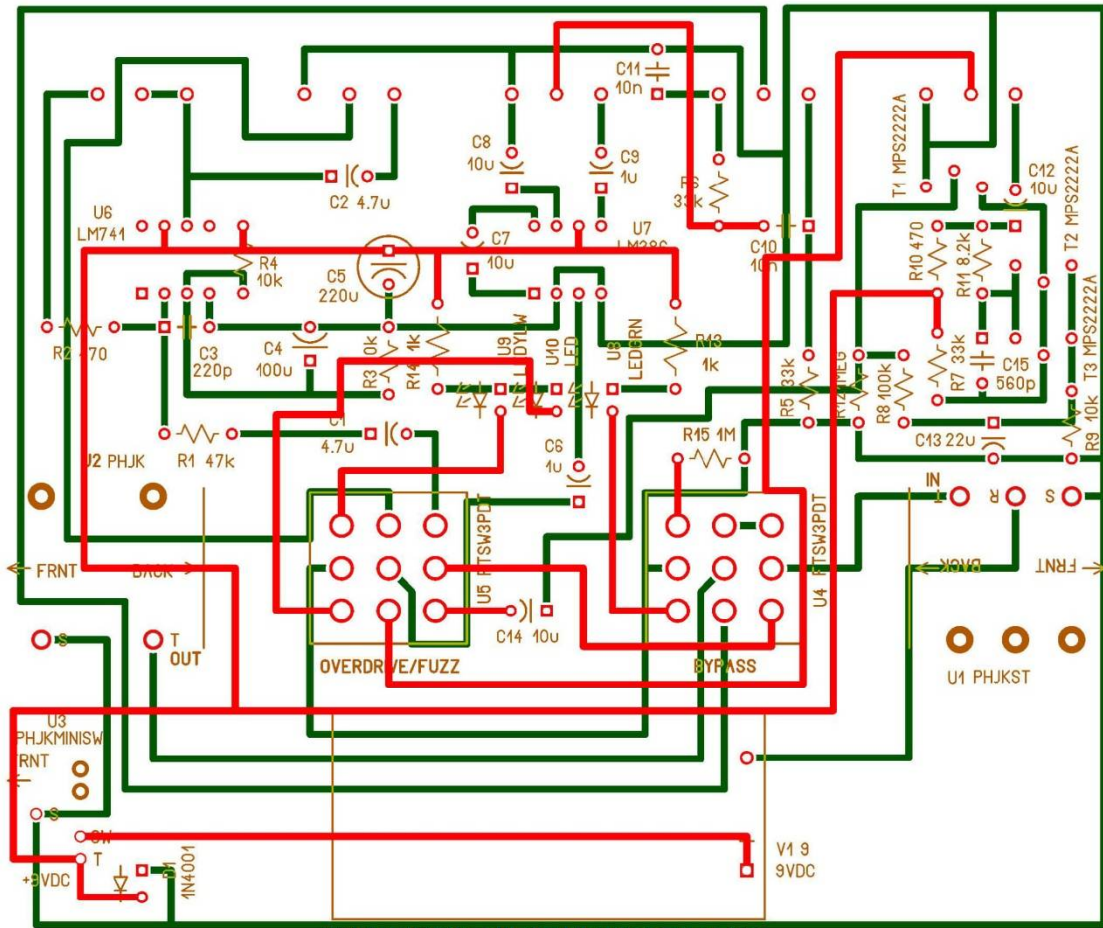

LM741-LM386 OVERDRIVE/FUZZ EFFECT

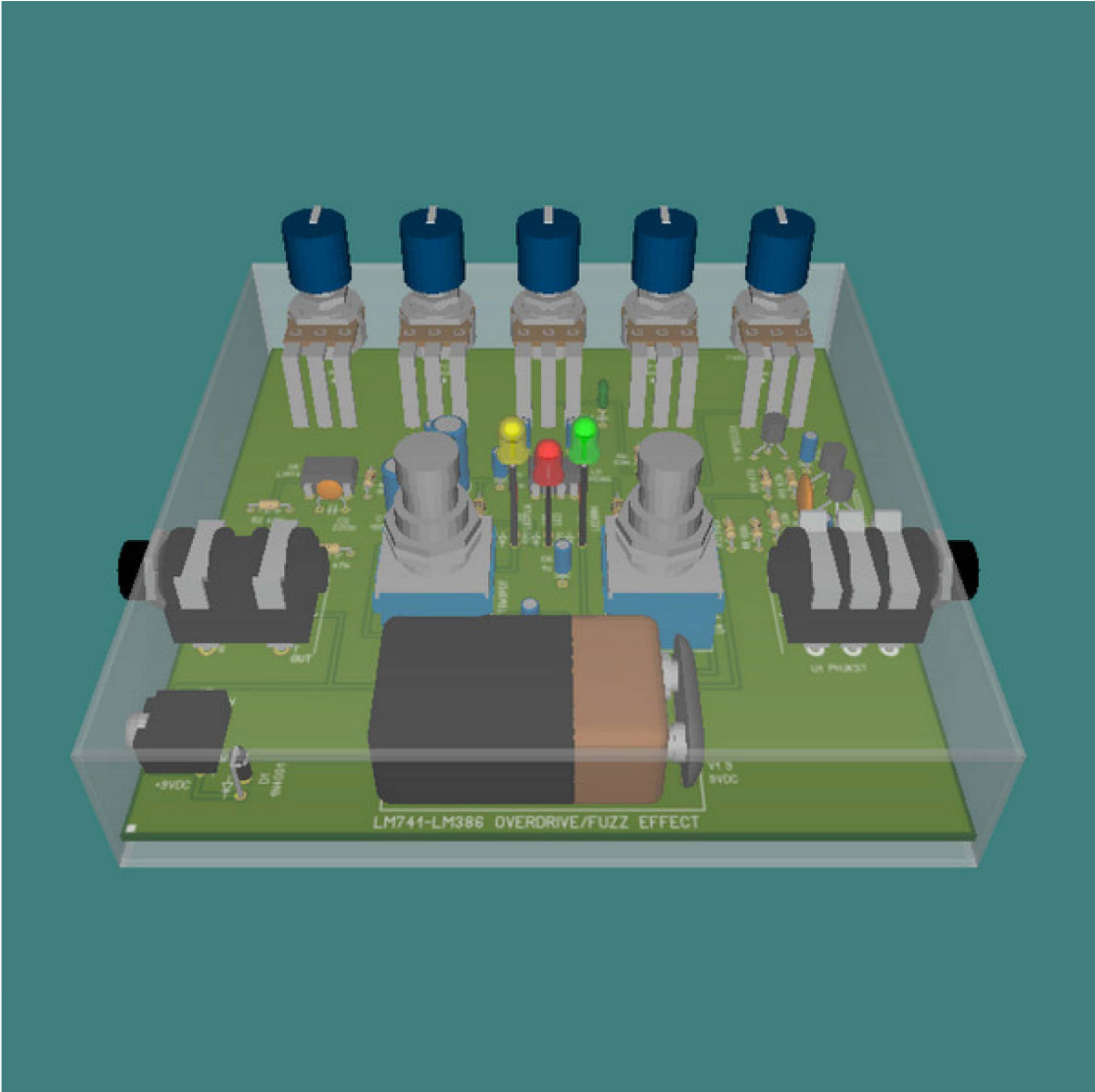

LM741/Transistors Octave Fuzz Effect

LM741/Transistors Octave Fuzz Effect Schematic

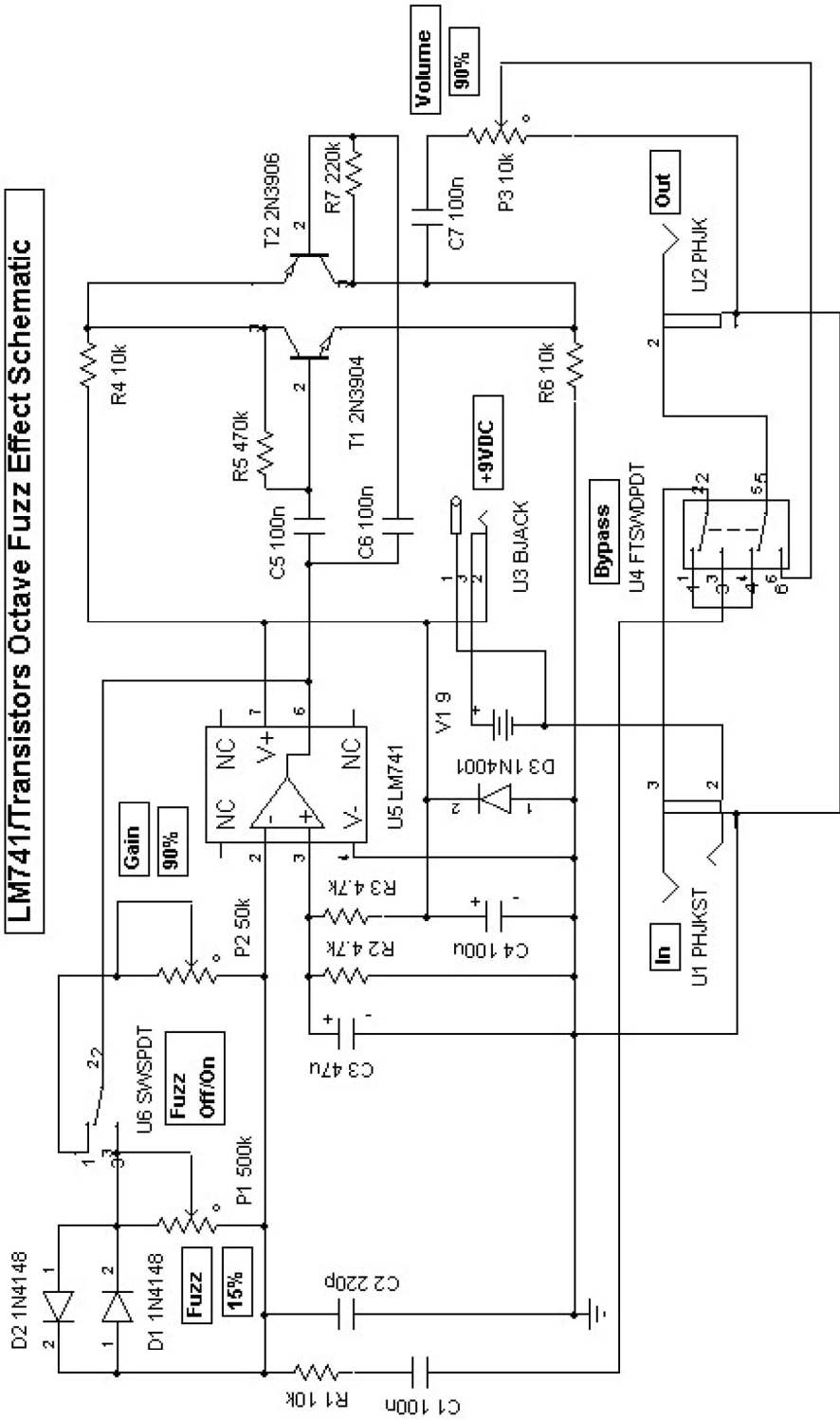

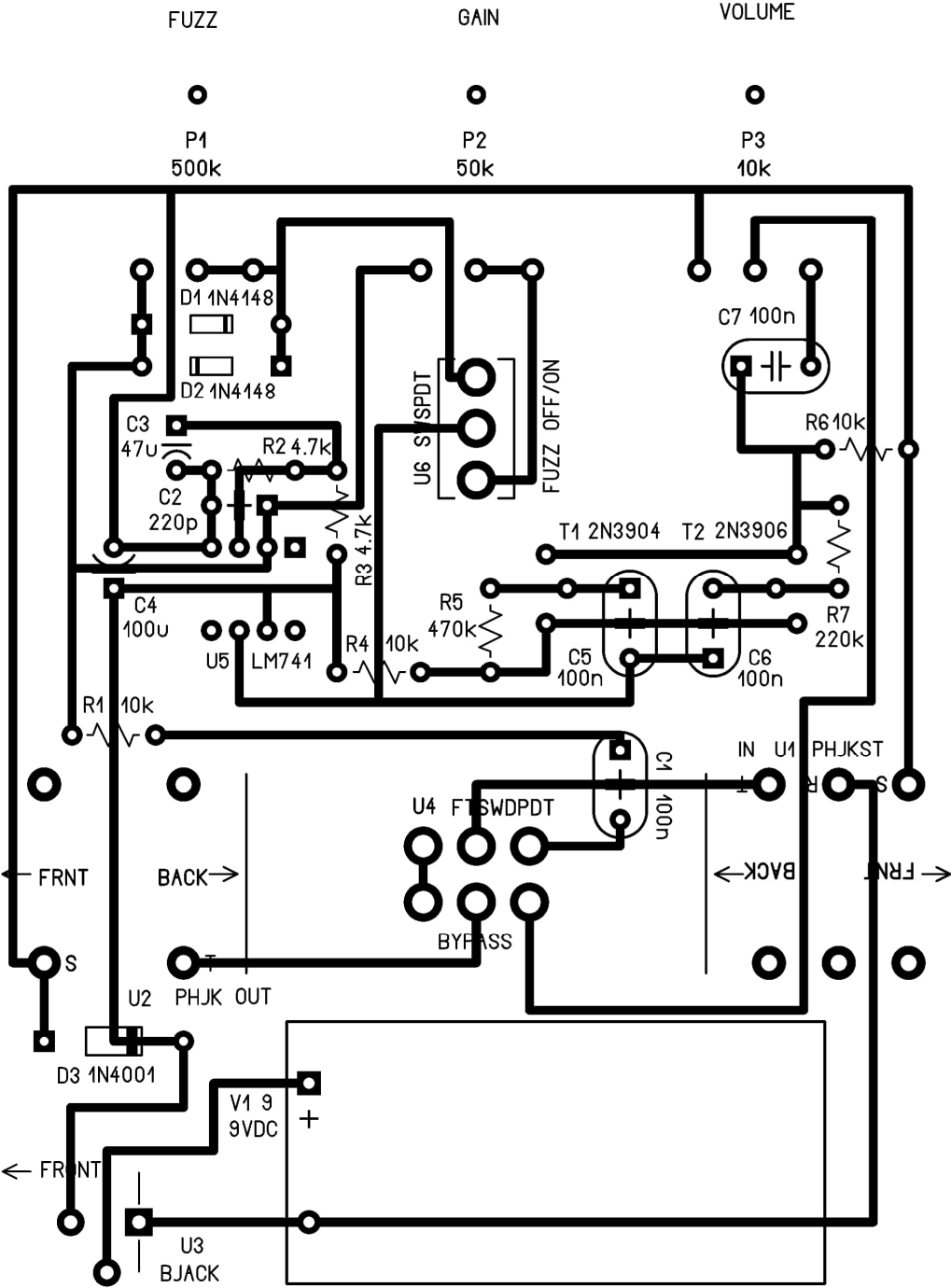

LM741/TRANSISTORS OCTAVE FUZZ EFFECT

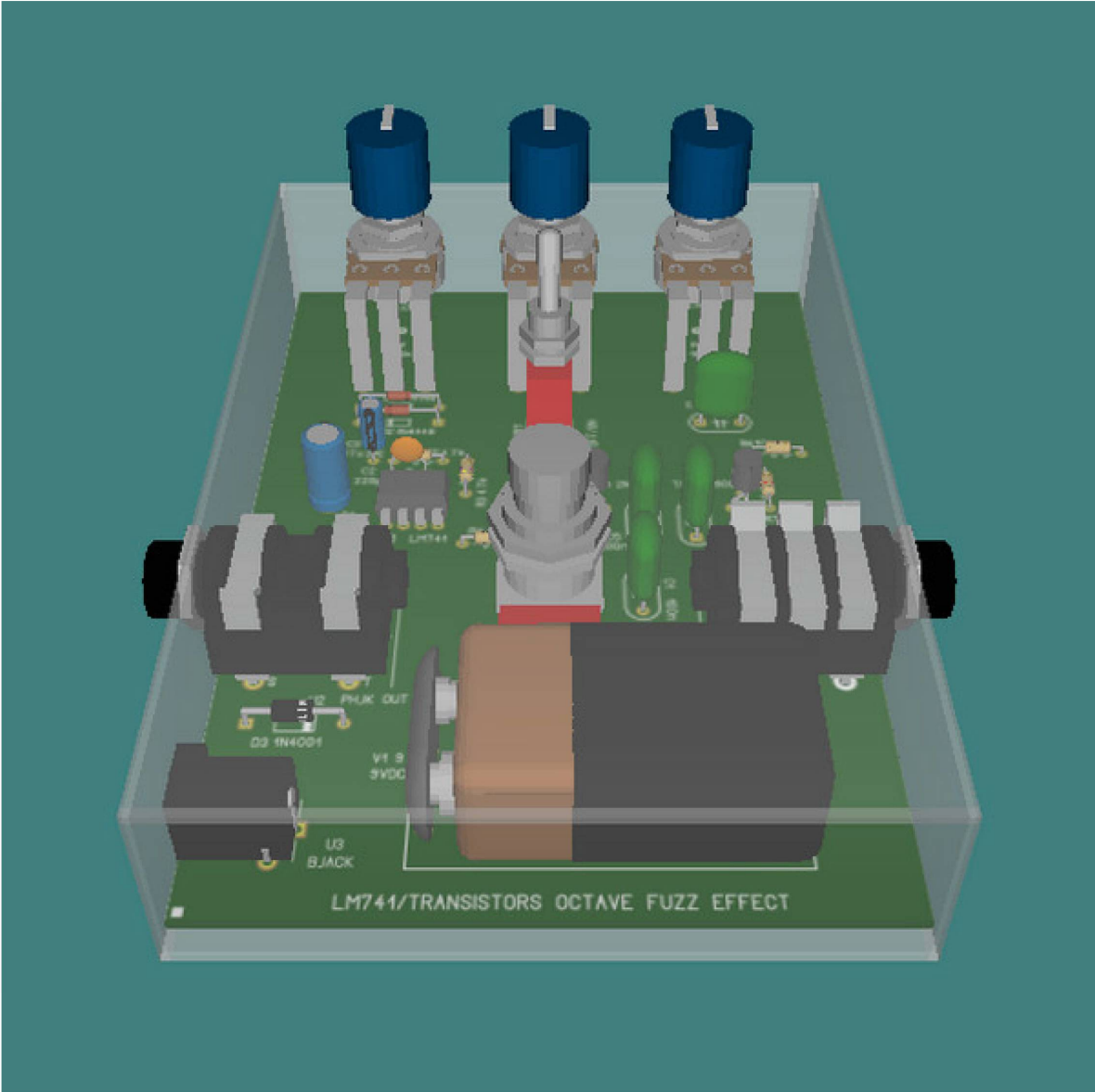

LM386/Transformer Octave Fuzz Effect

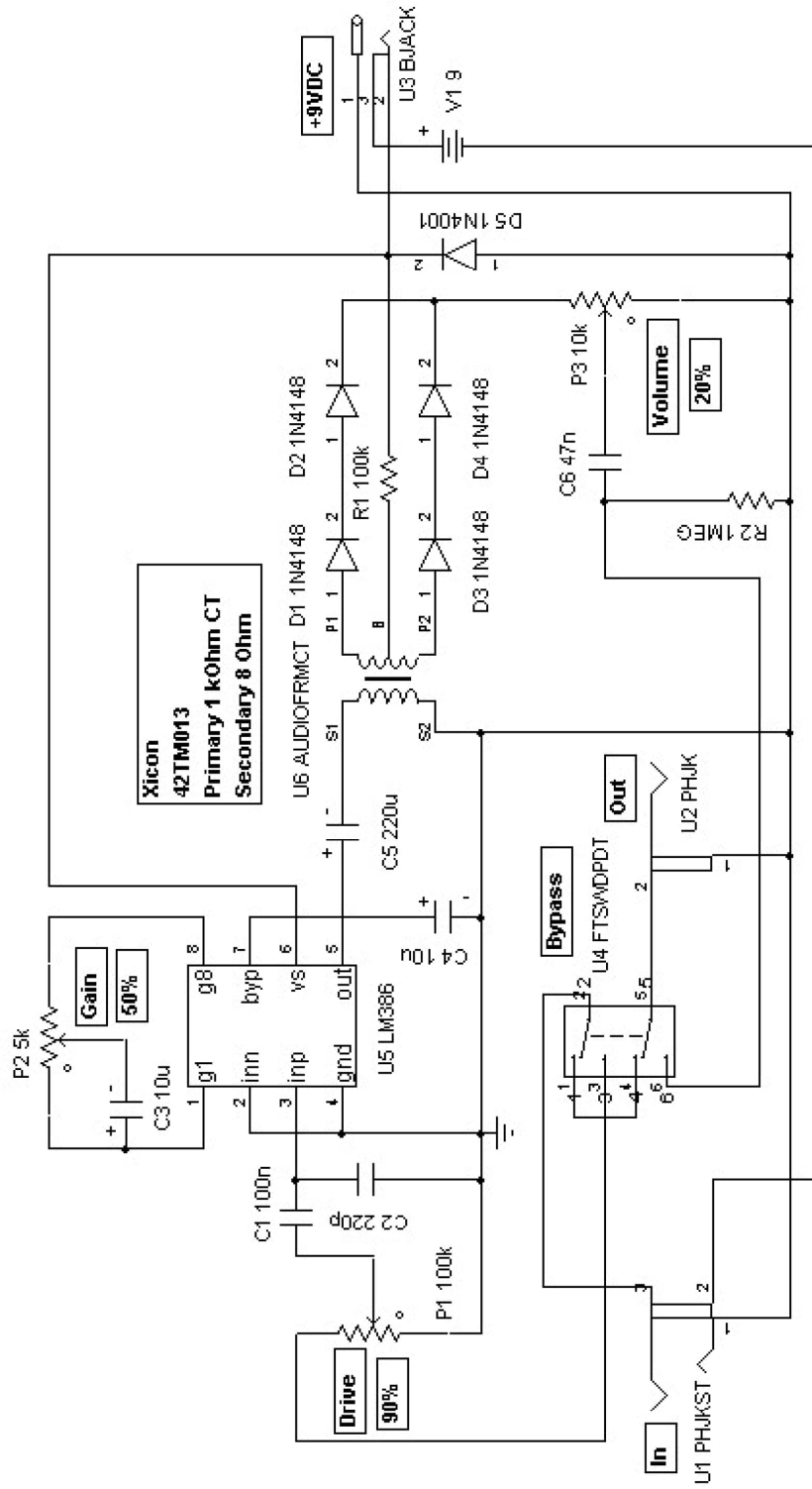

LM386/Transformer Octave Fuzz Effect Schematic

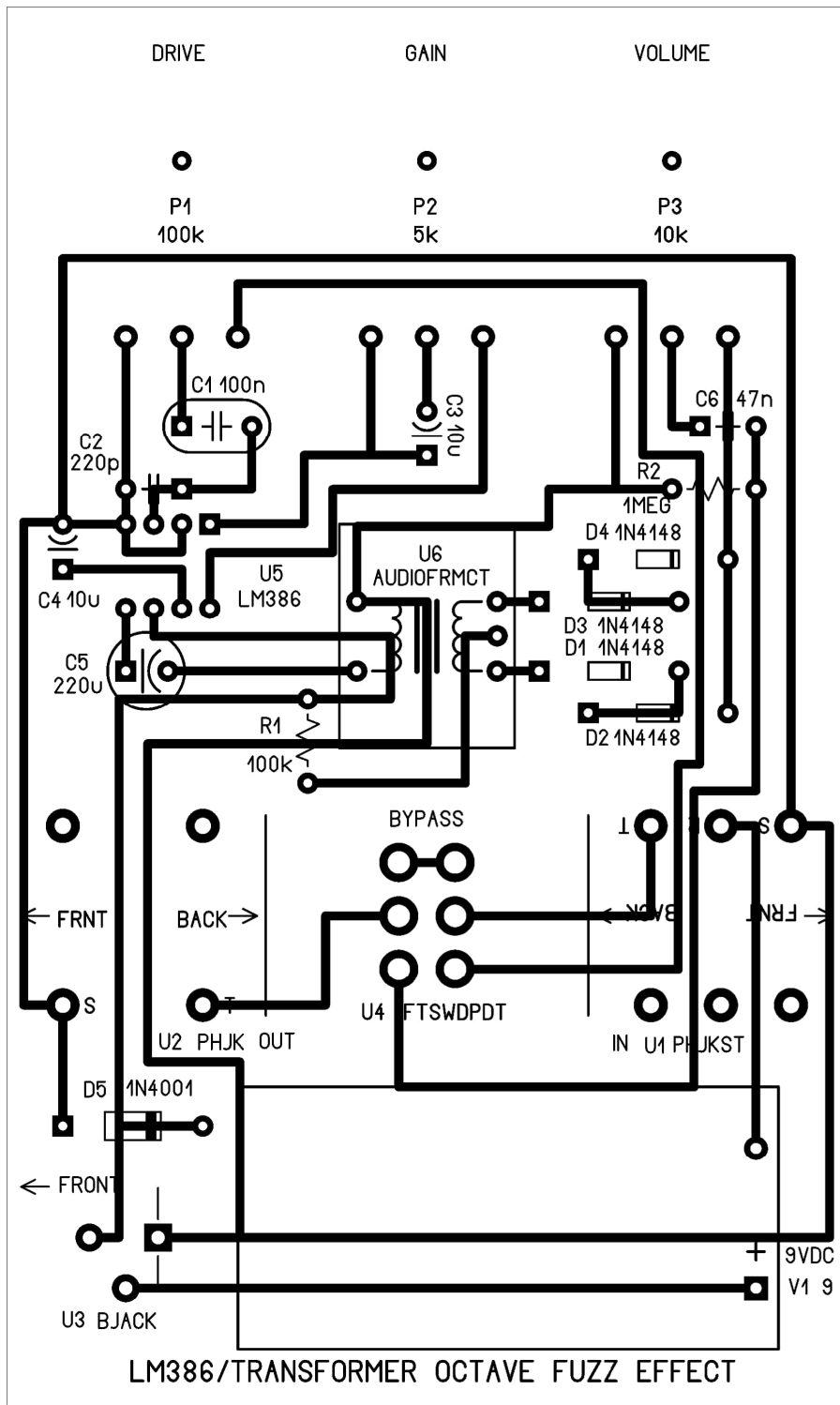

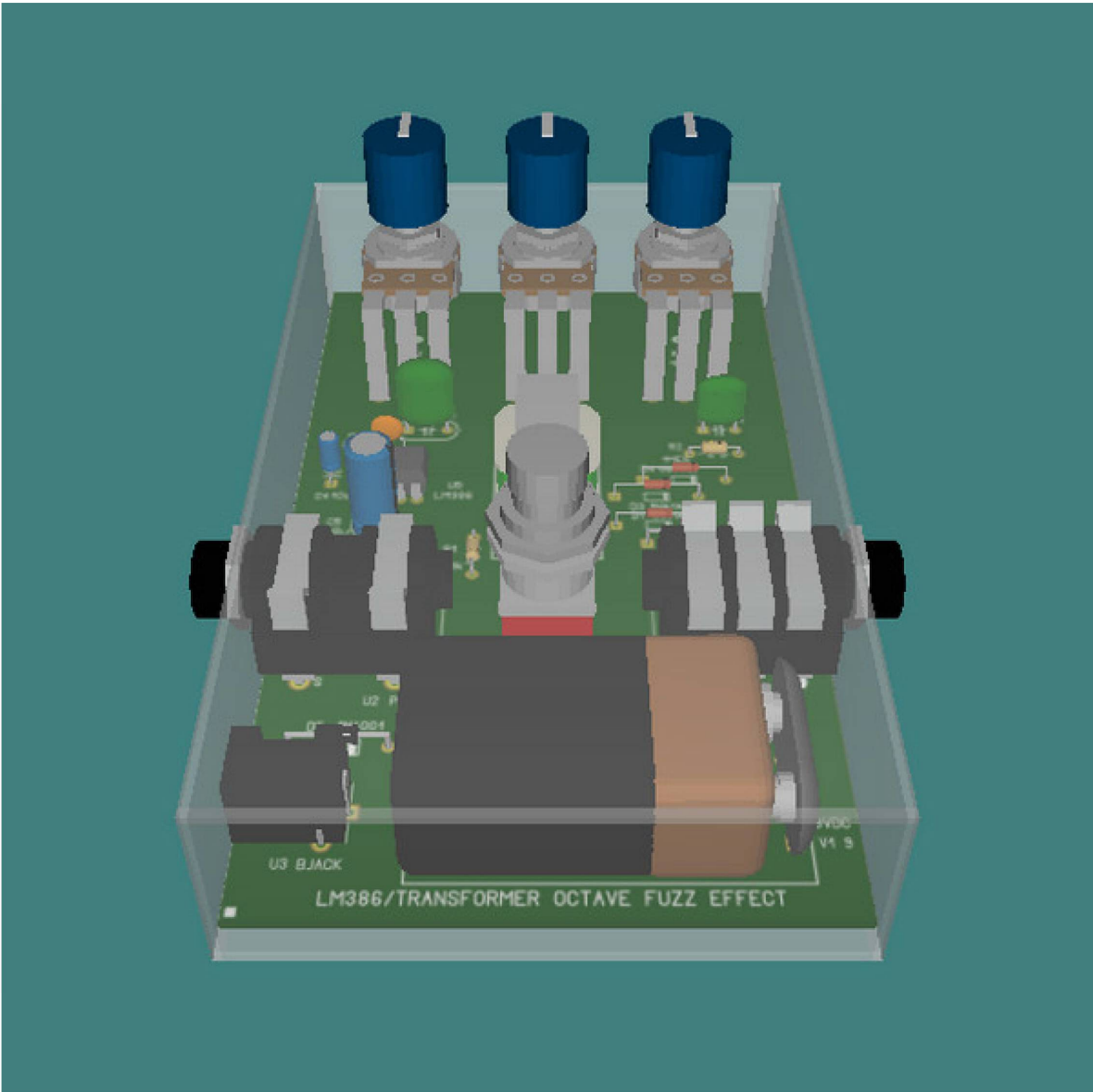

Transistors/Transformer Octave Fuzz Effect Schematic

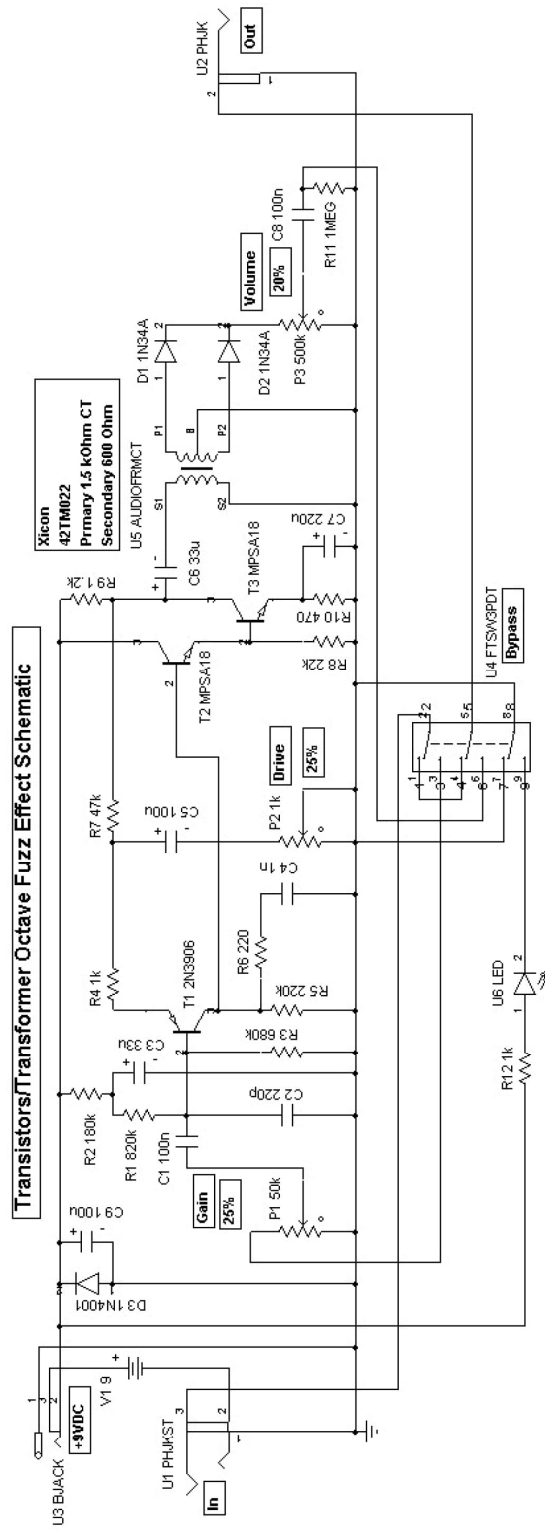

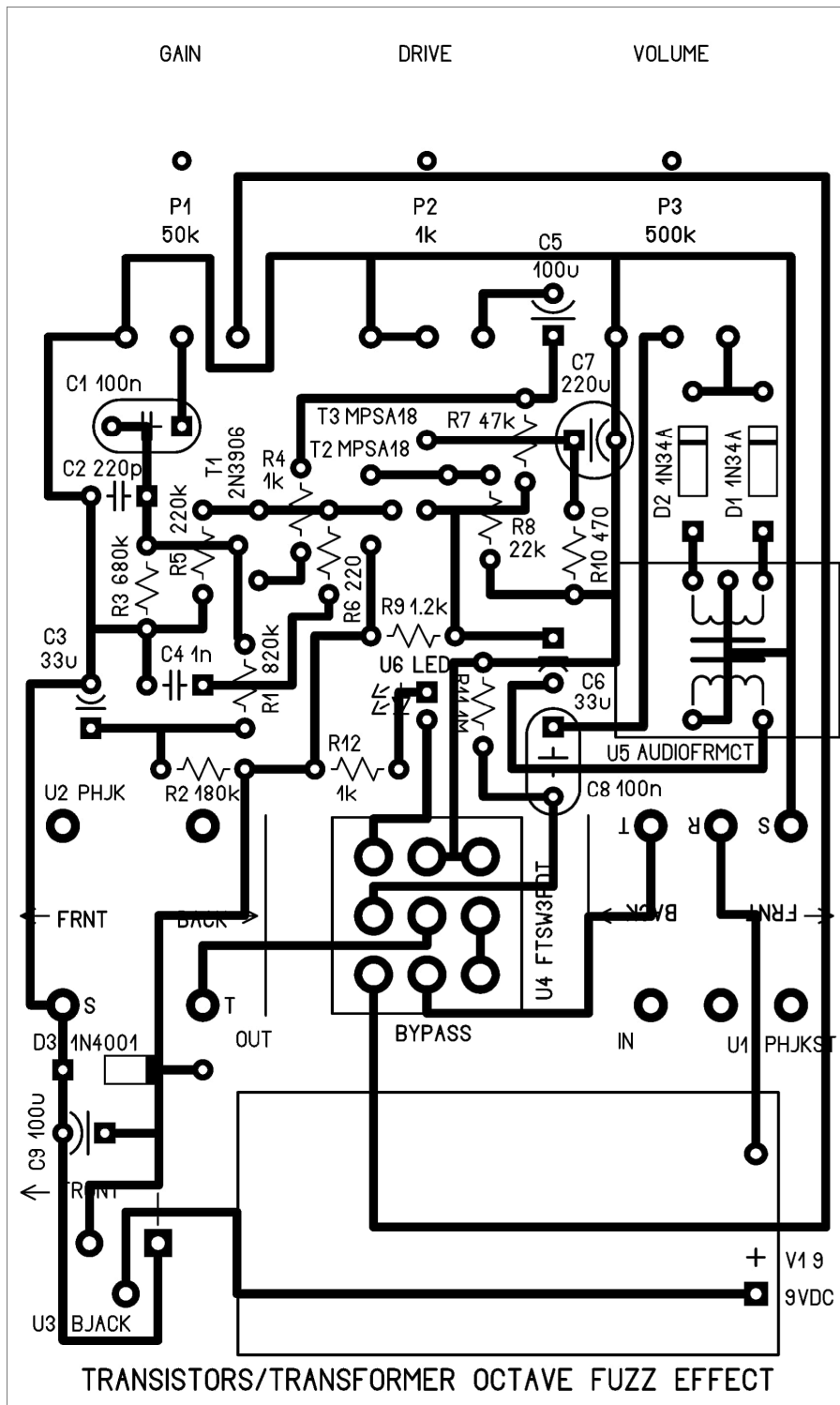

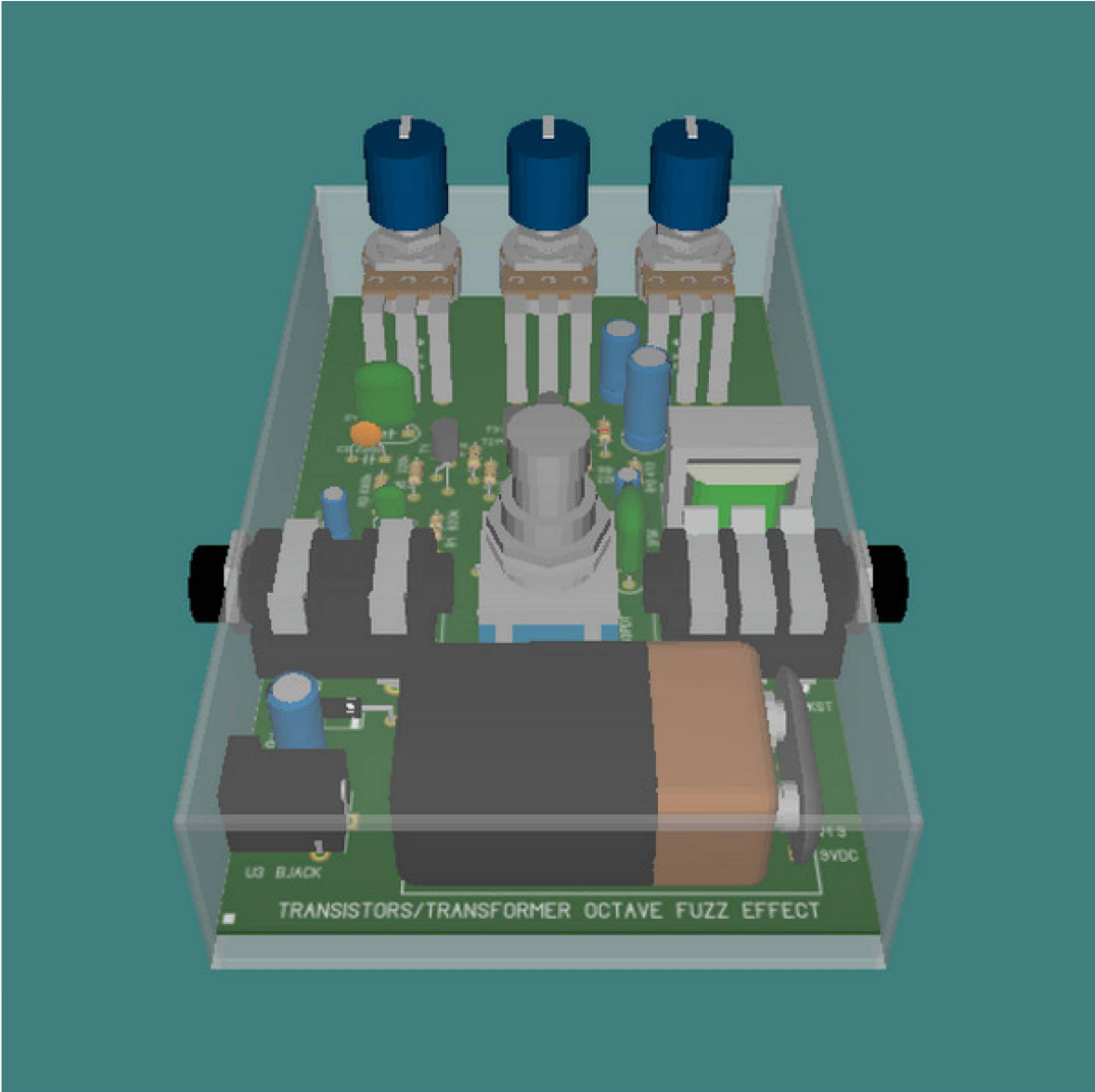

Transistors Octave Fuzz Effect

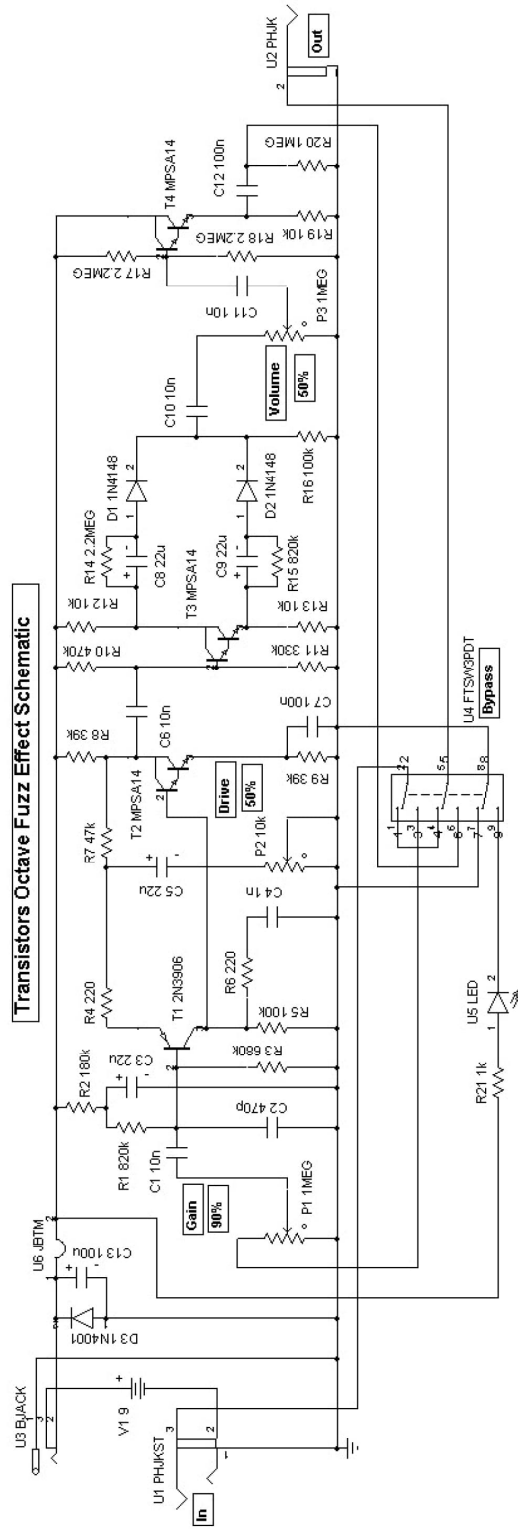

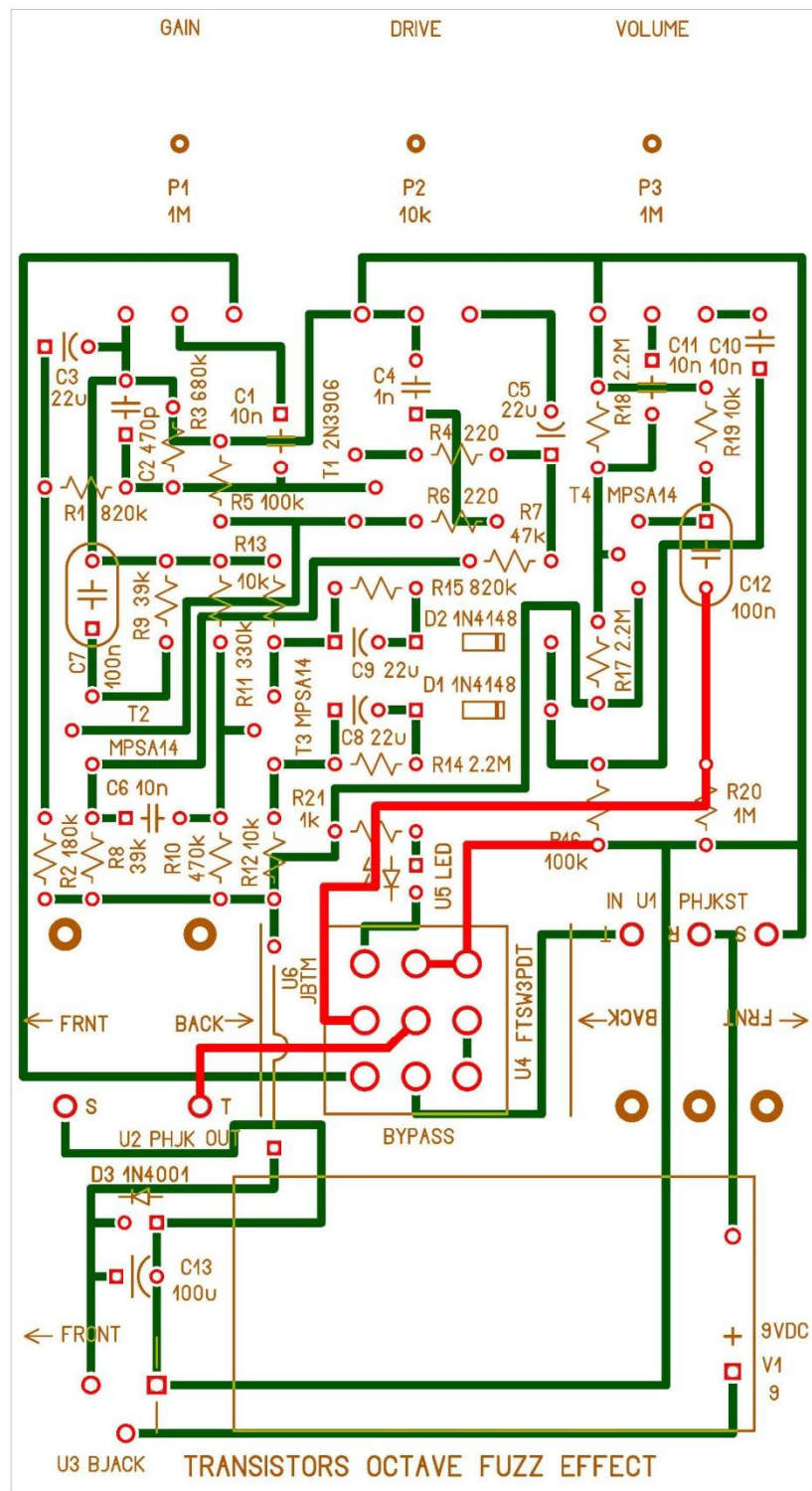

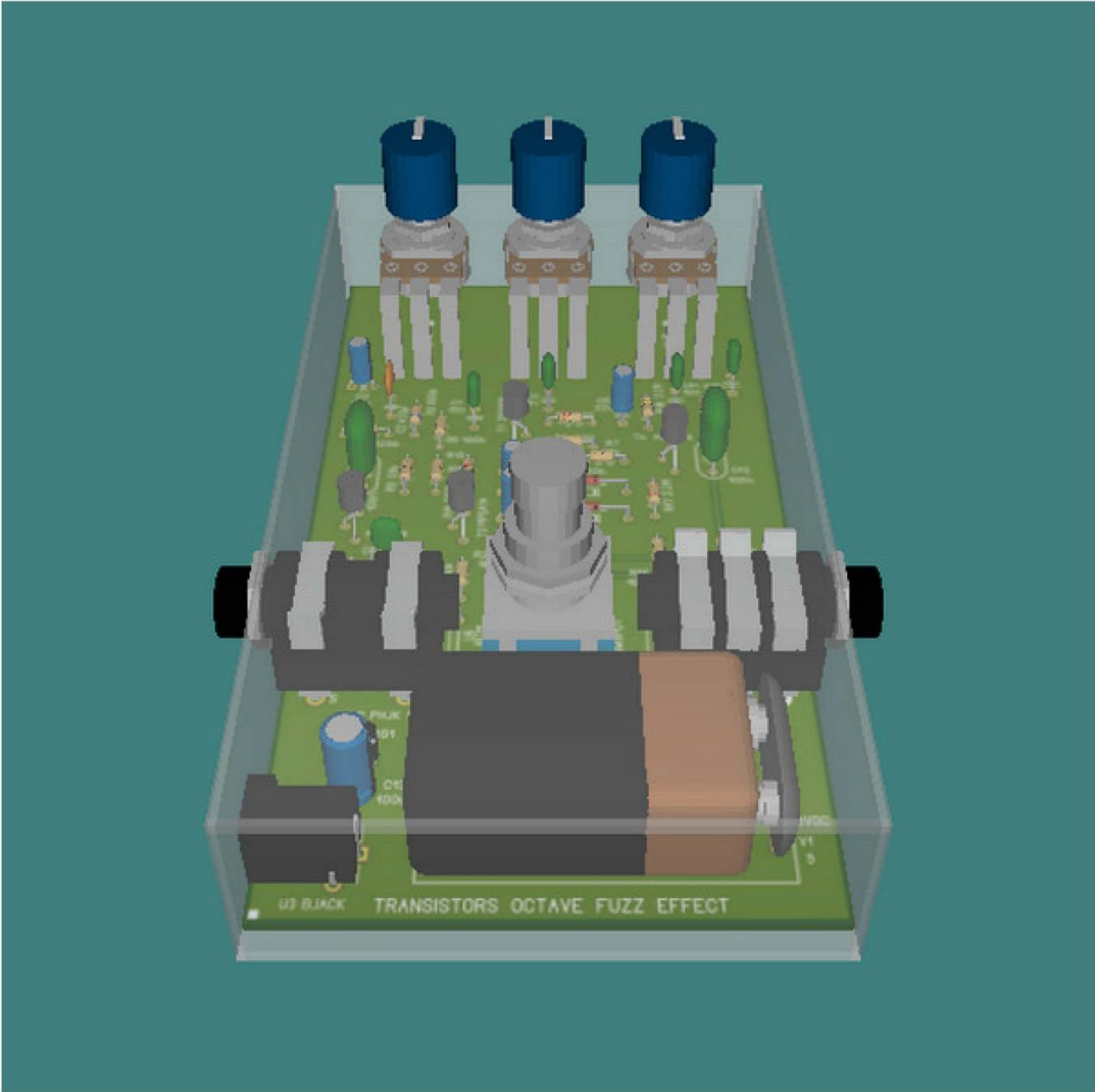

Octave SuperFuzz Effect

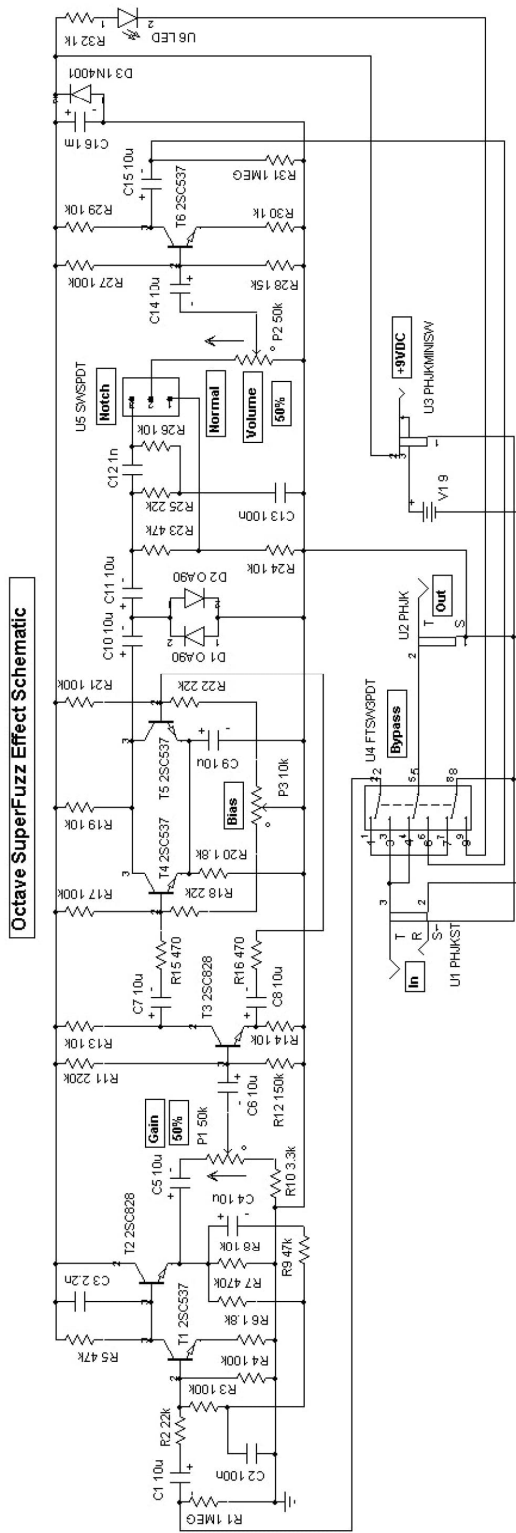

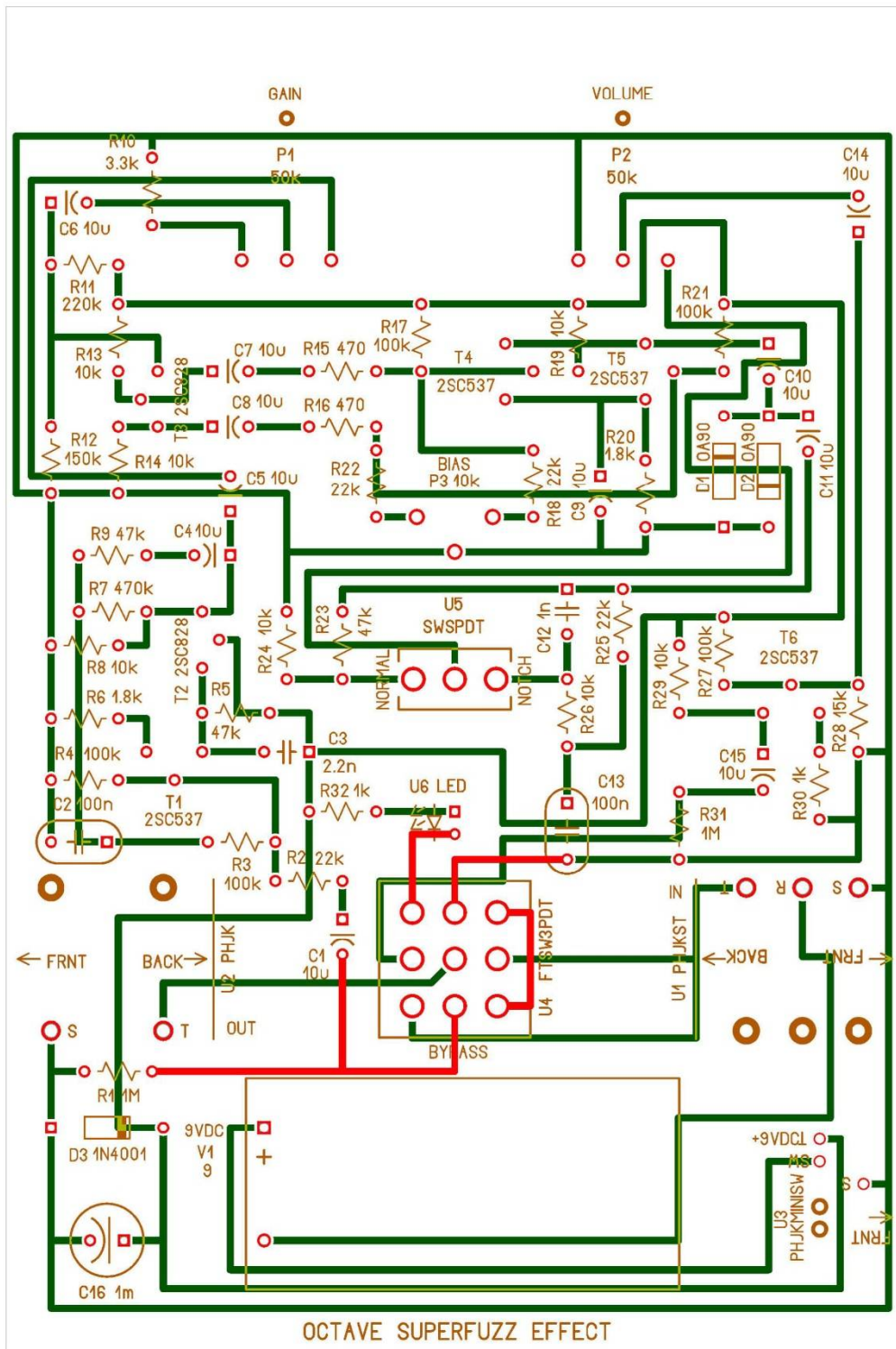

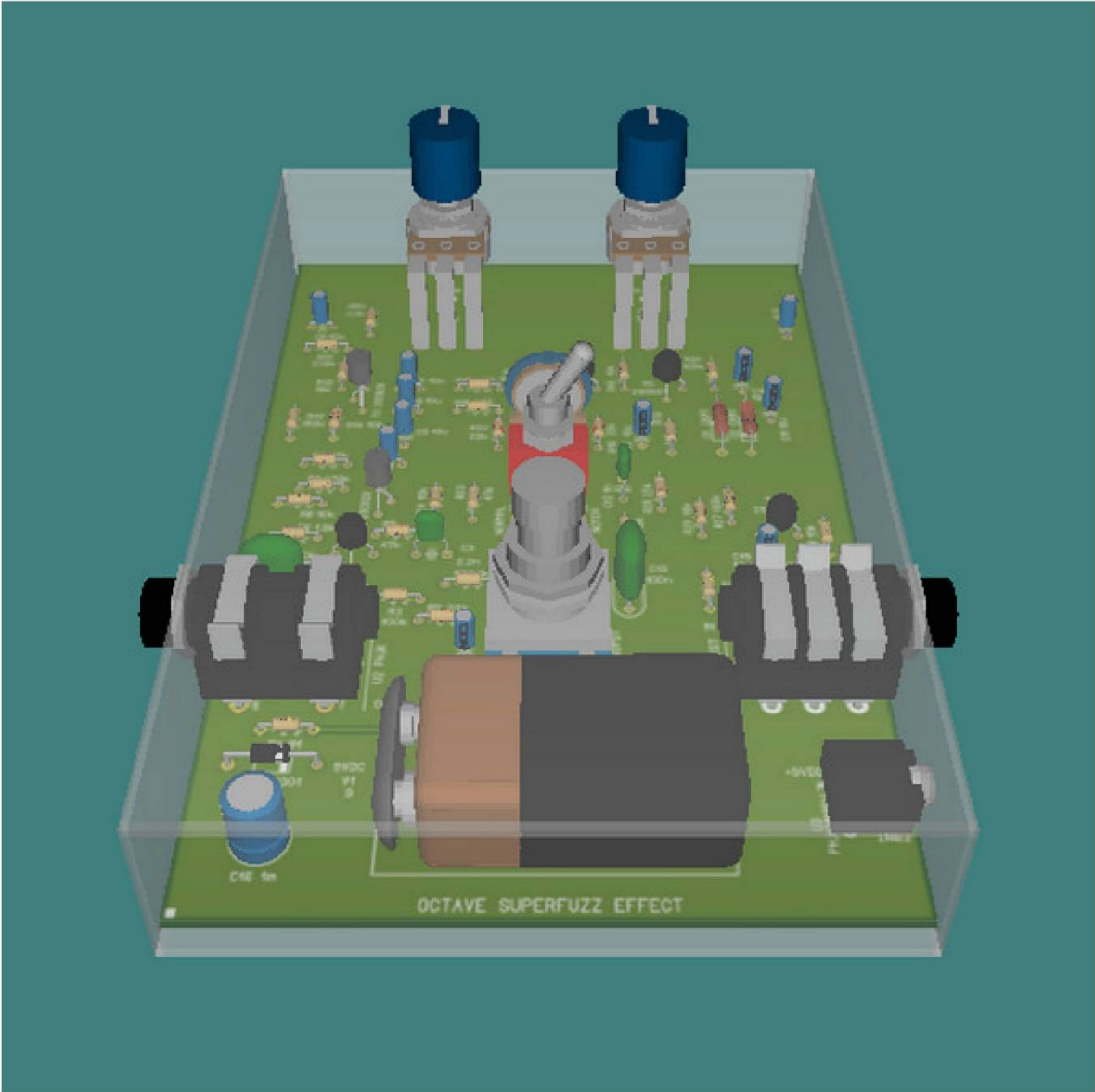

Big Muff 1Pi

Big Muff 1Pi Effect Schematic

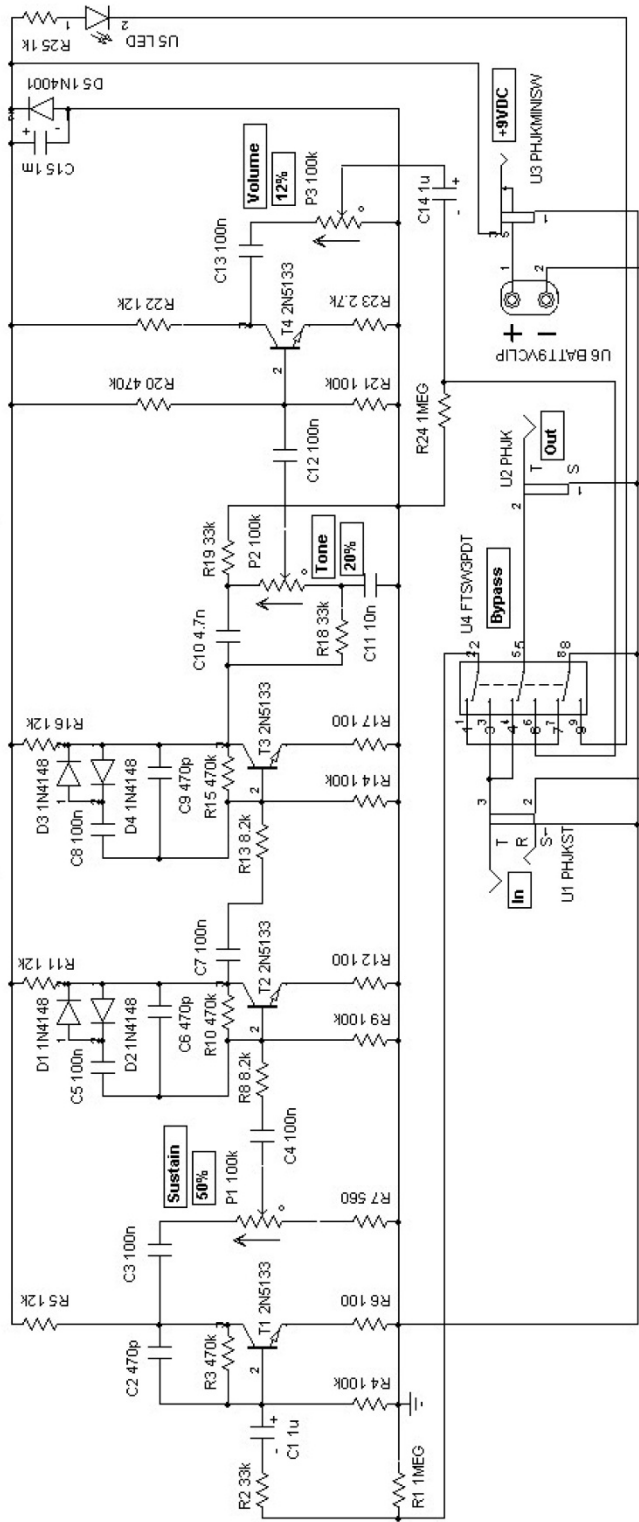

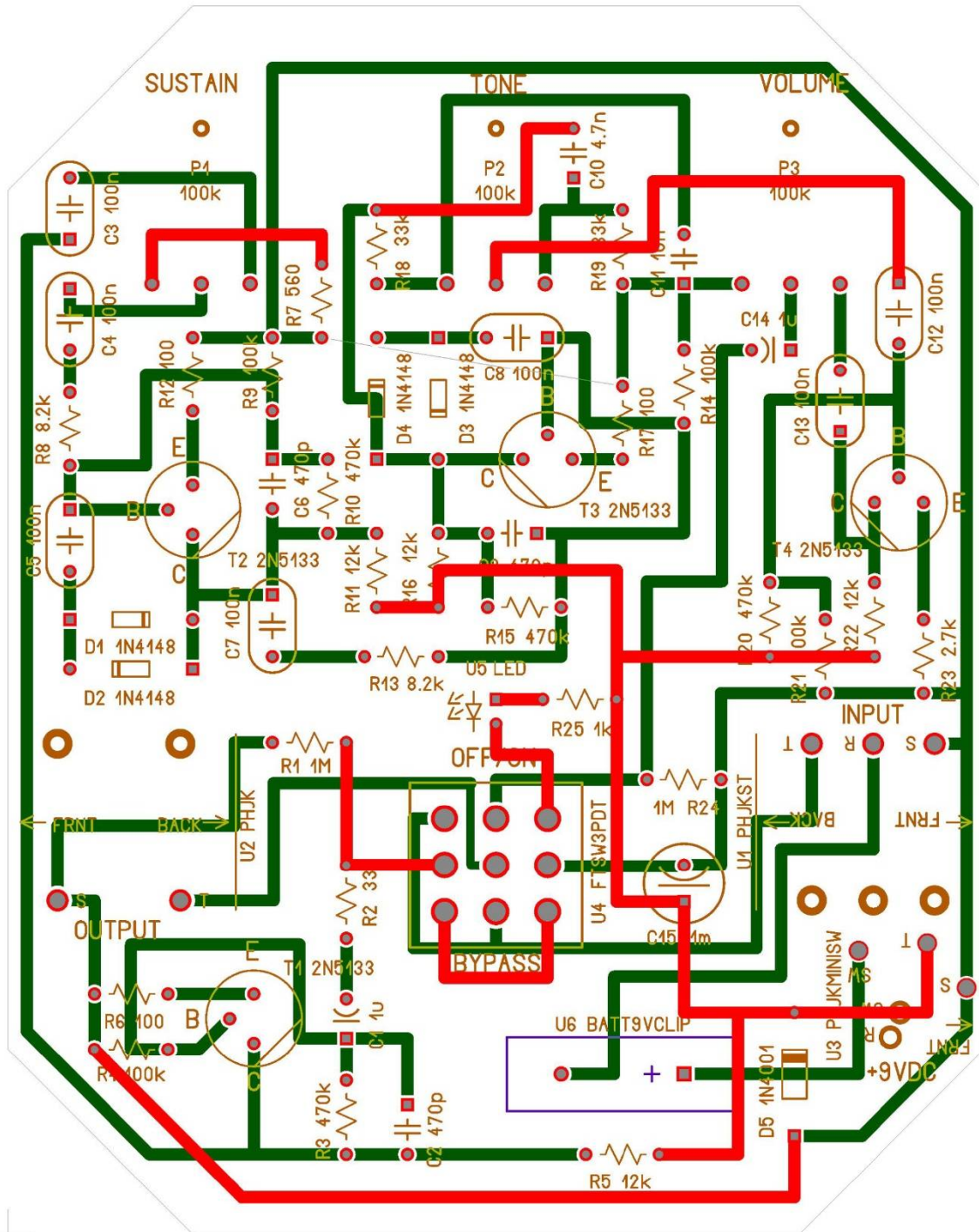

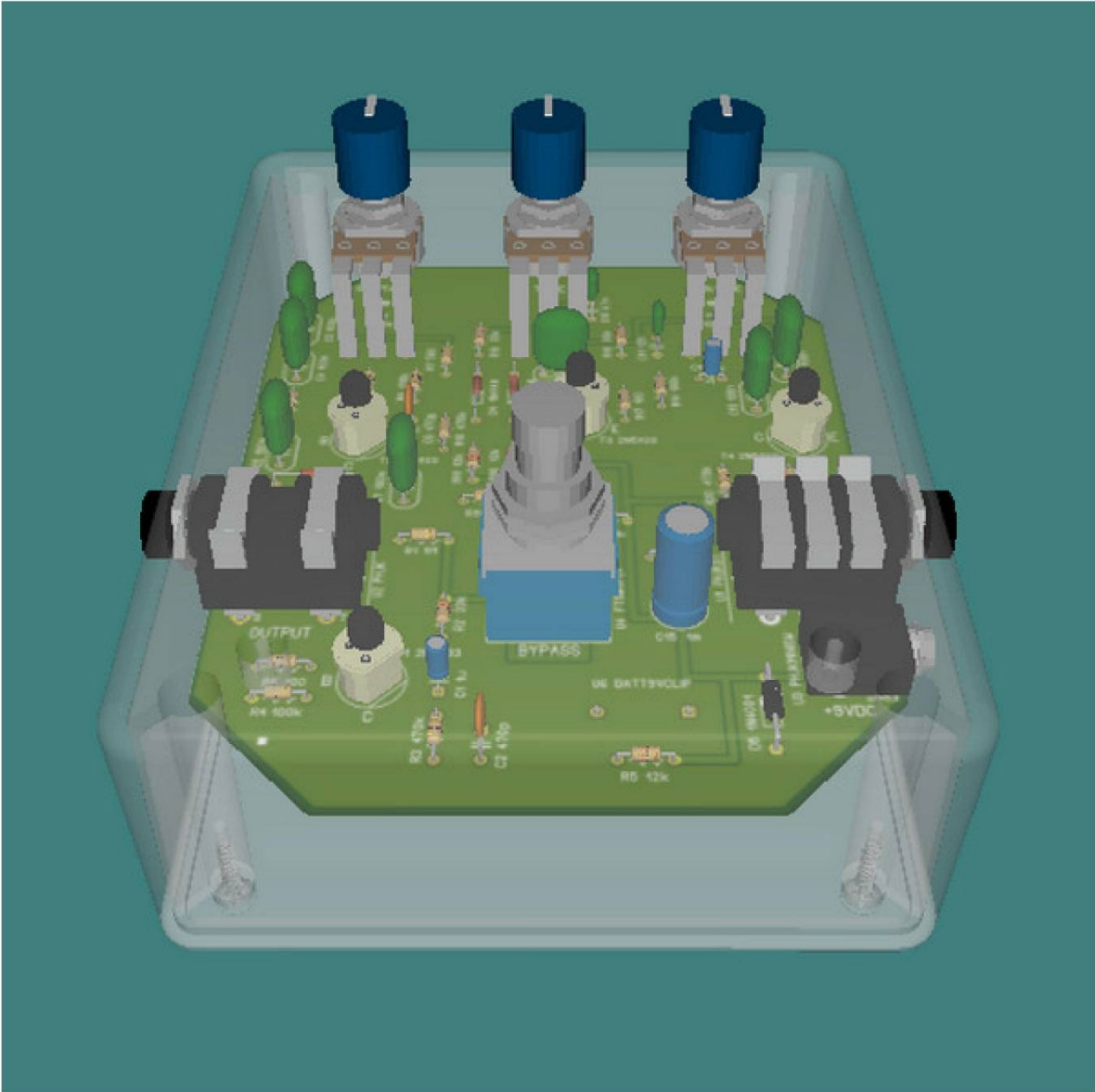

Big Muff 2Pi

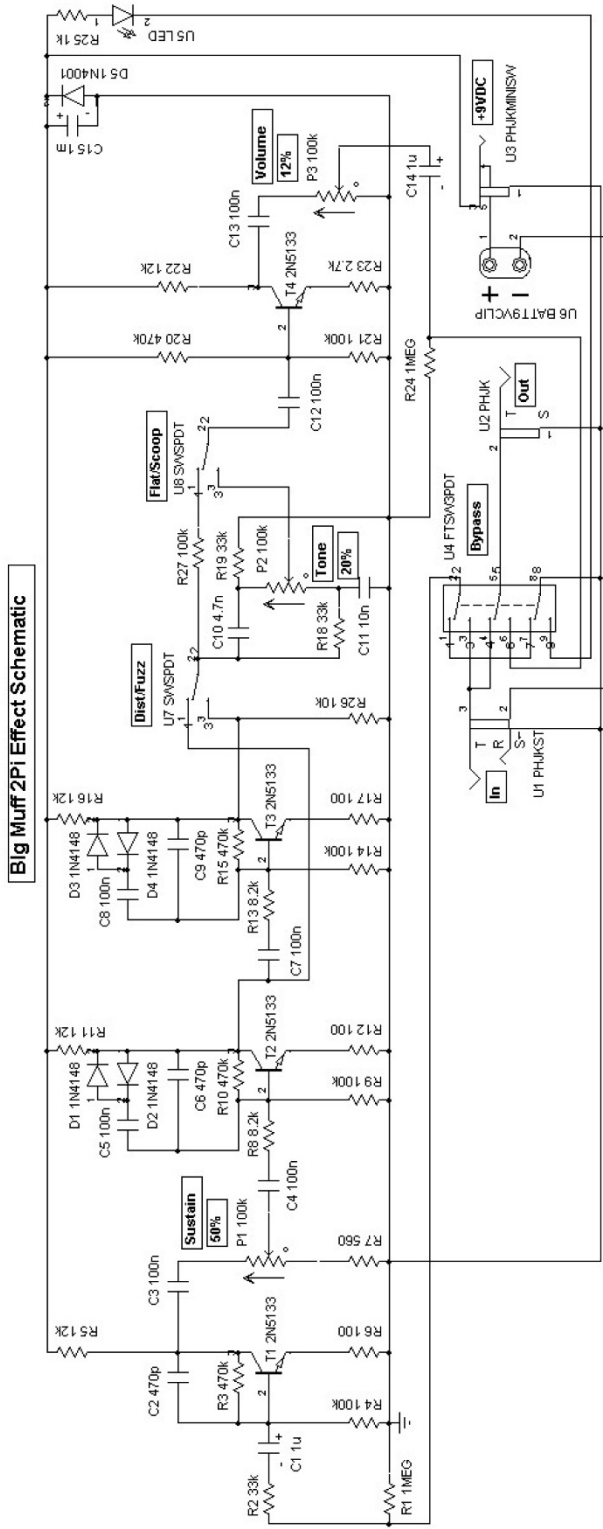

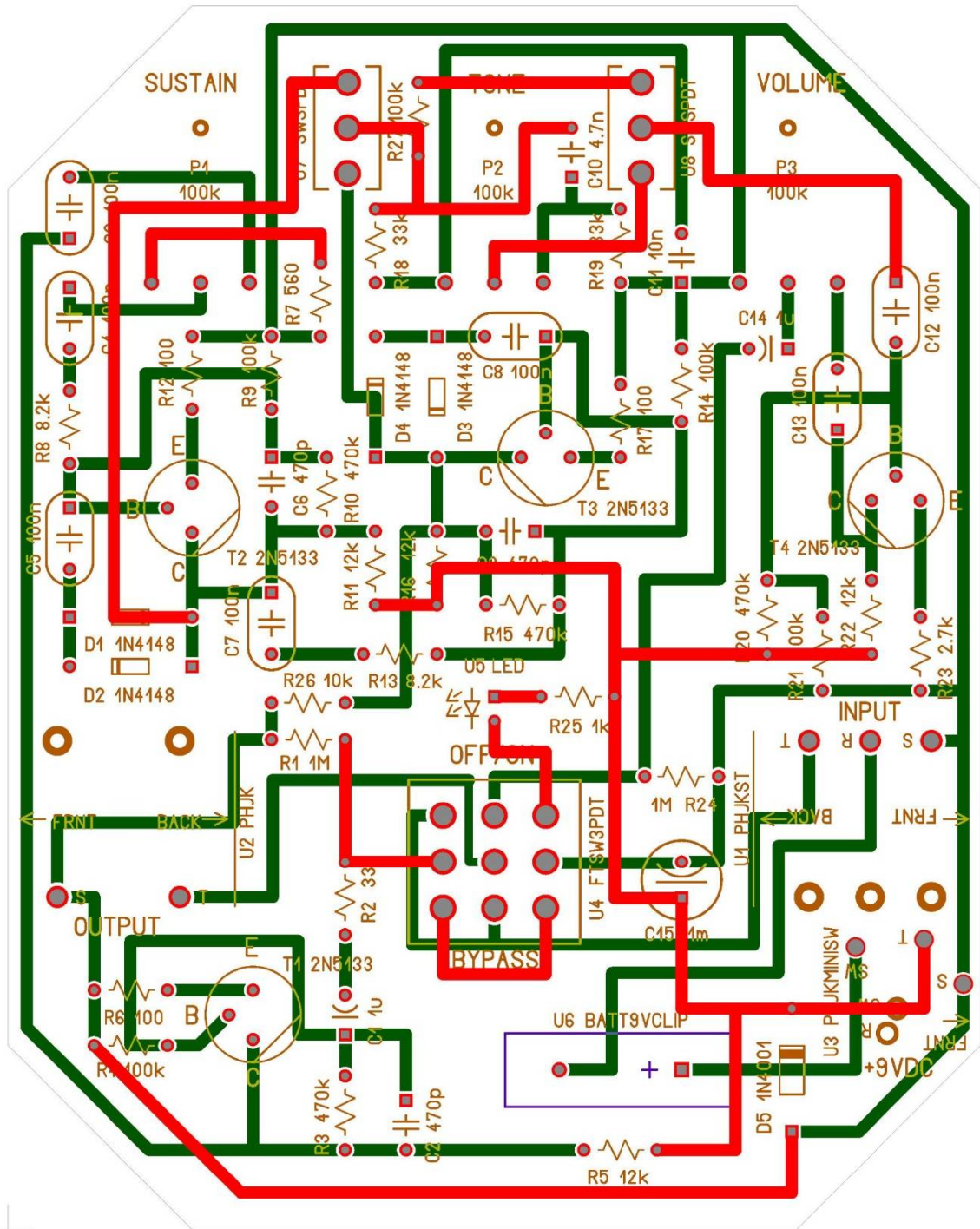

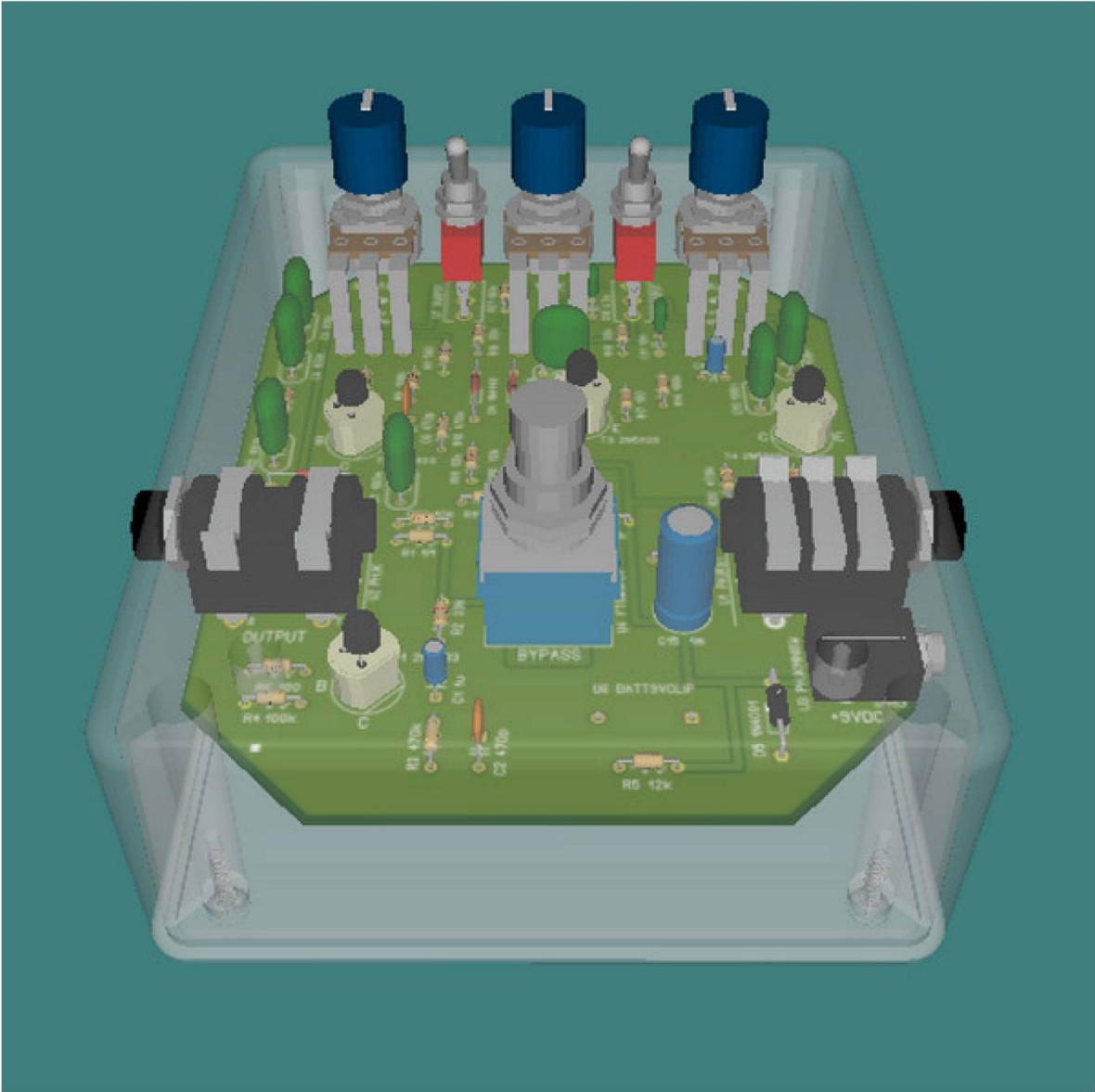

Plug-In Electric Guitar Fuzz Effect

Plug-In Electric Guitar Fuzz Effect Schematic

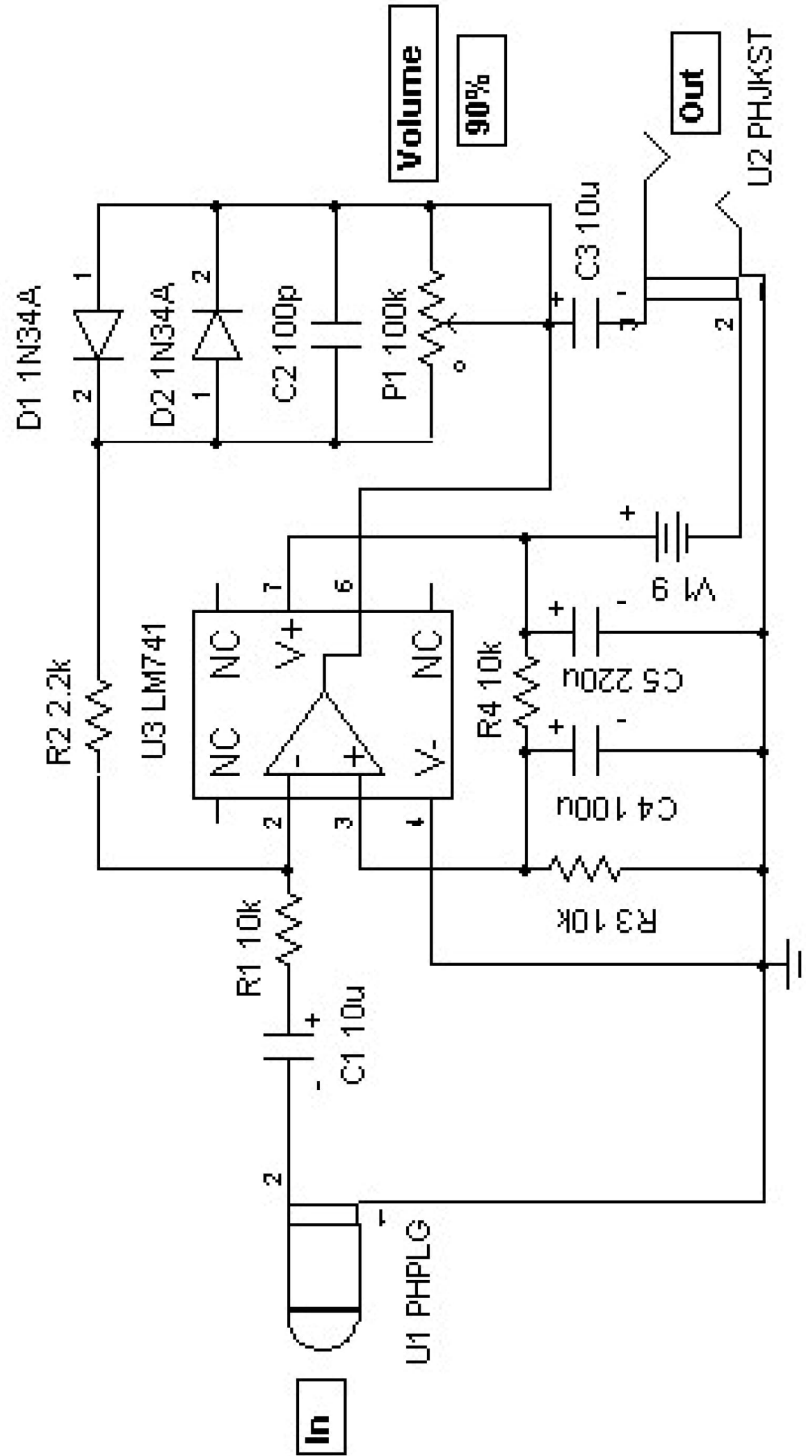

PLUG-IN ELECTRIC GUITAR FUZZ EFFECT

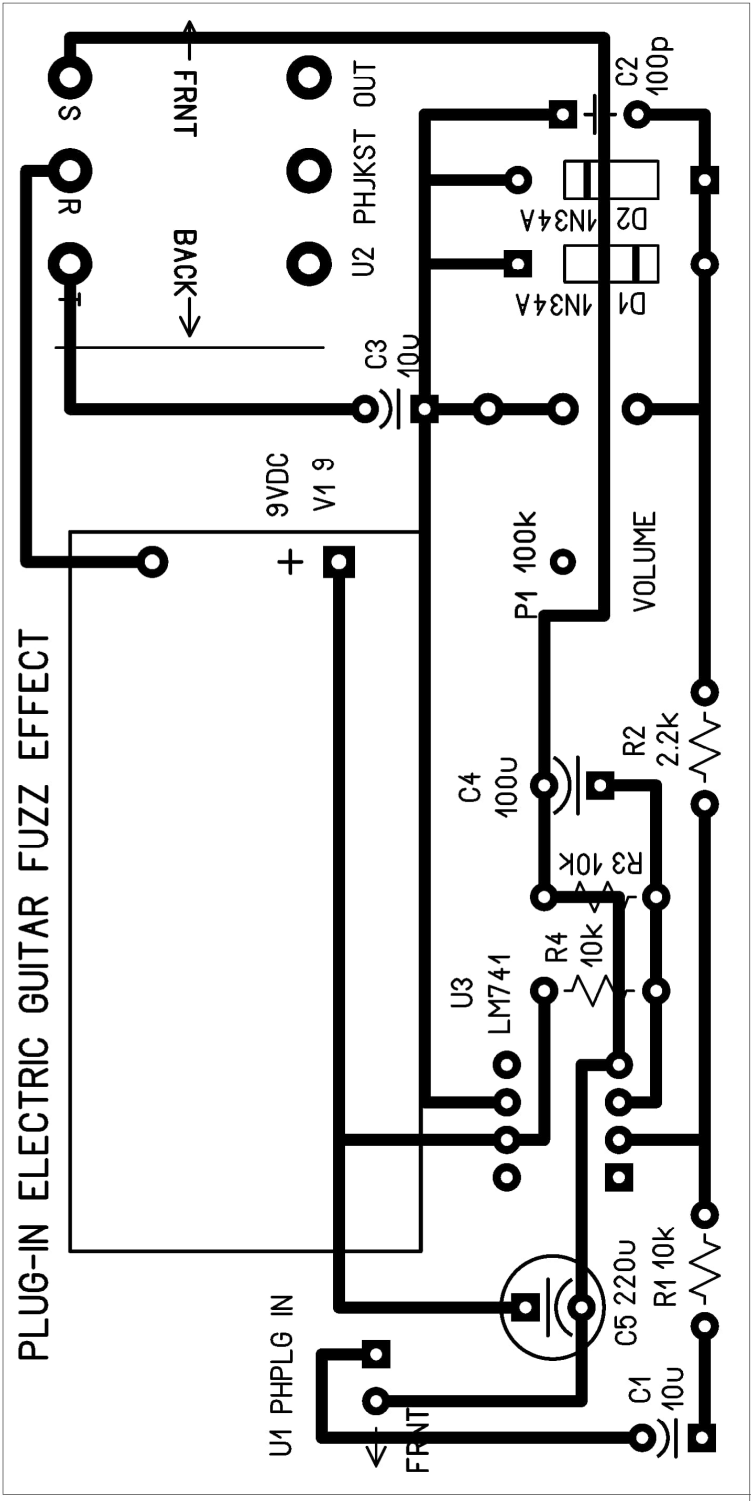

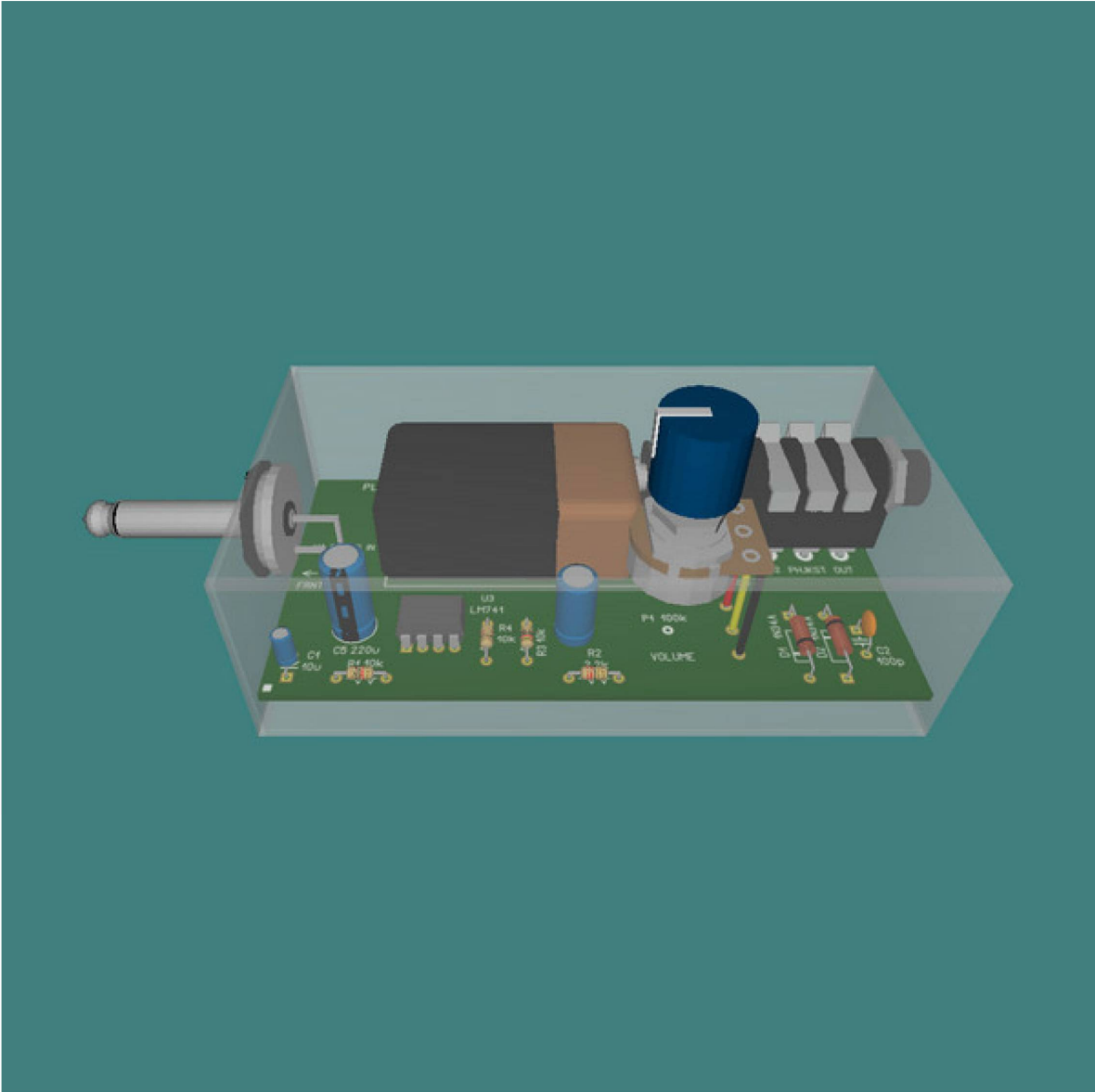

OpAmp/12AX7A Tube Overdrive Effect Schematic

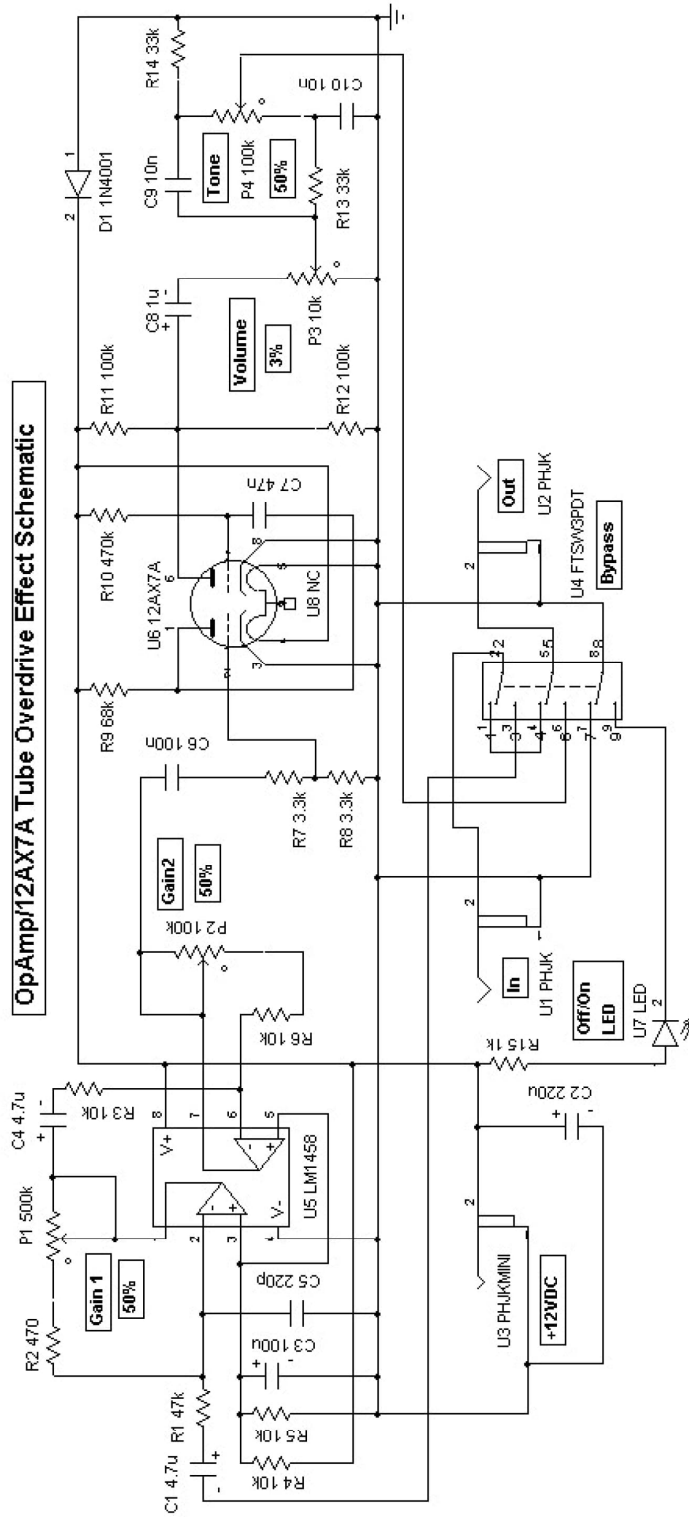

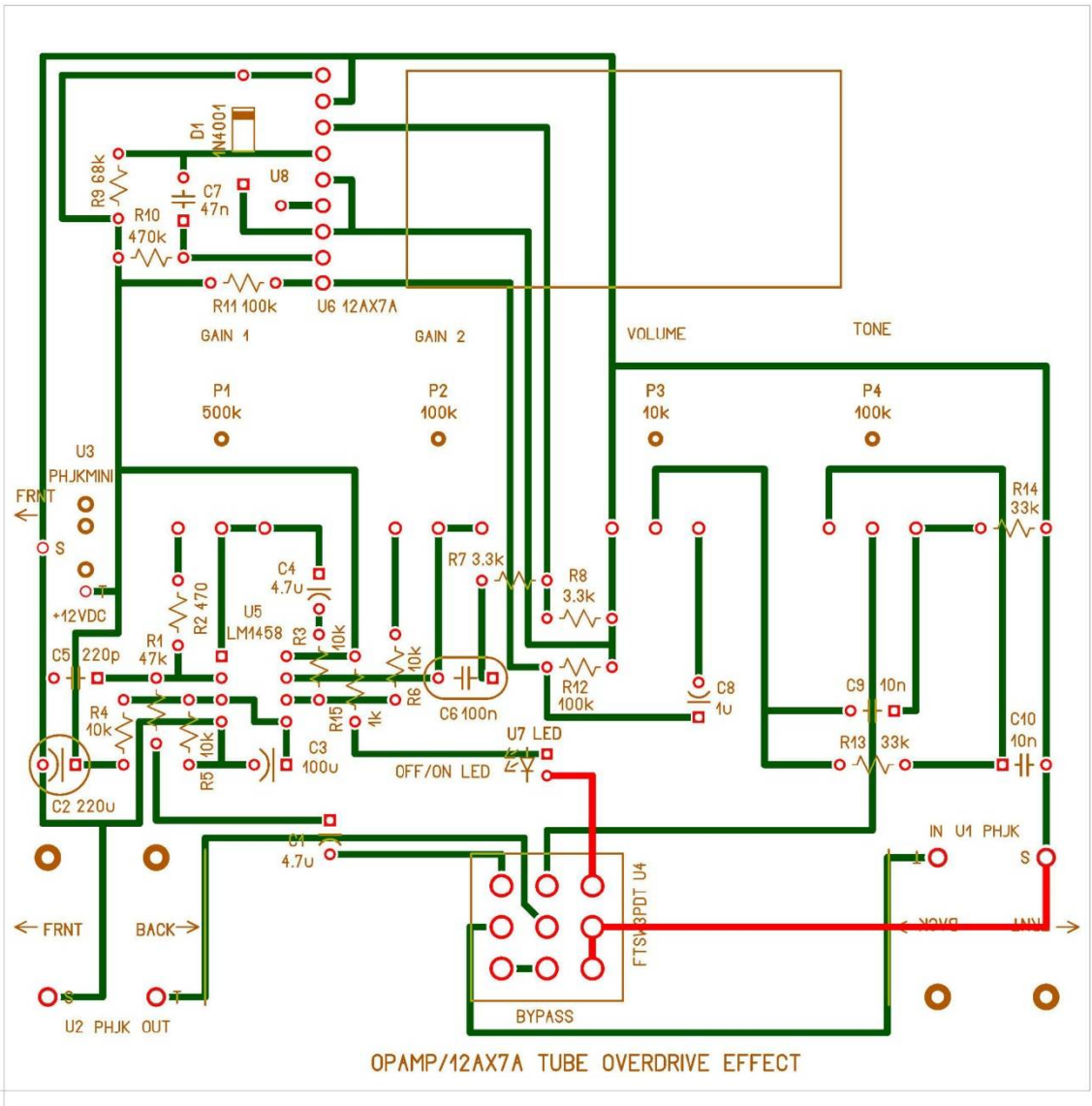

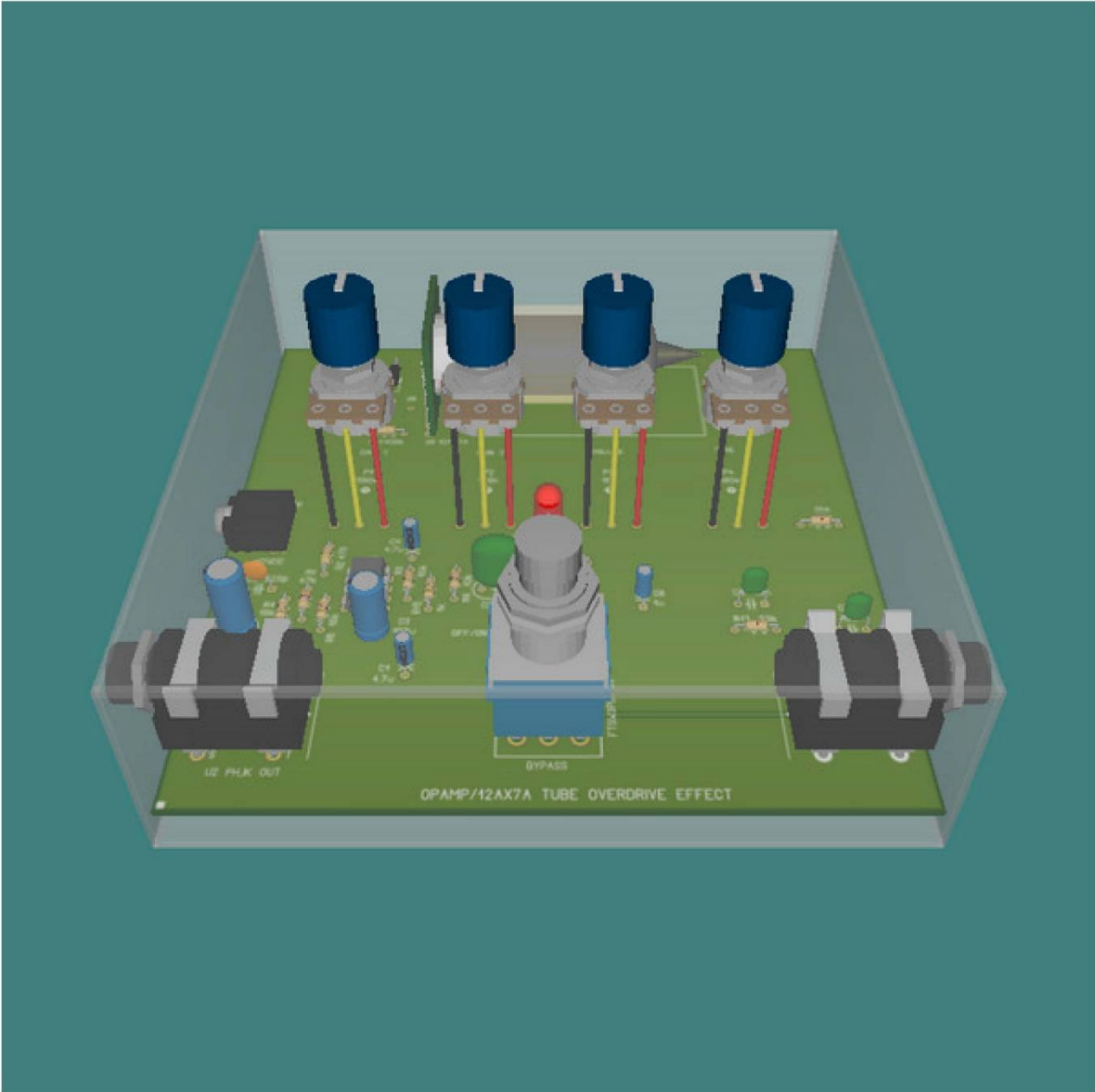

OpAmp/12AX7A Tube Overdrive Effect 2

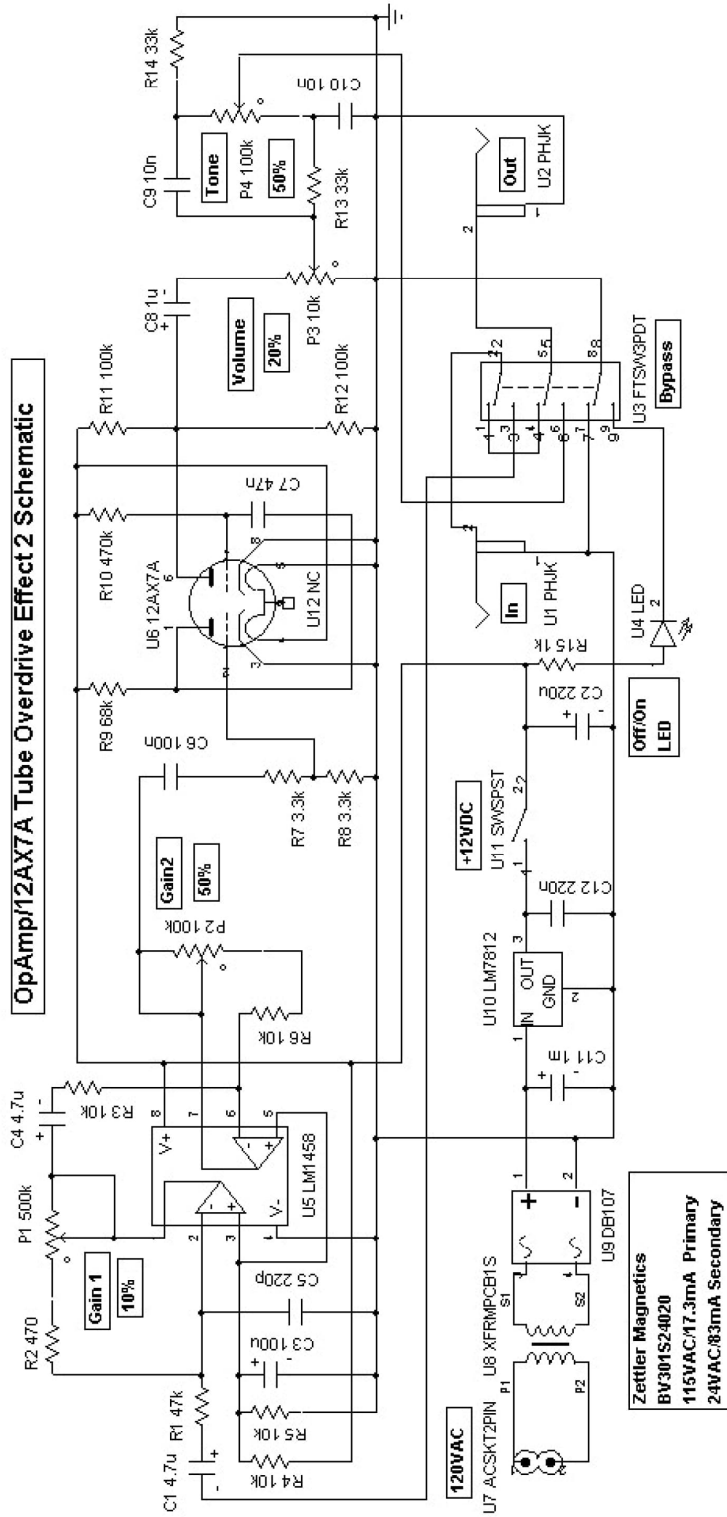

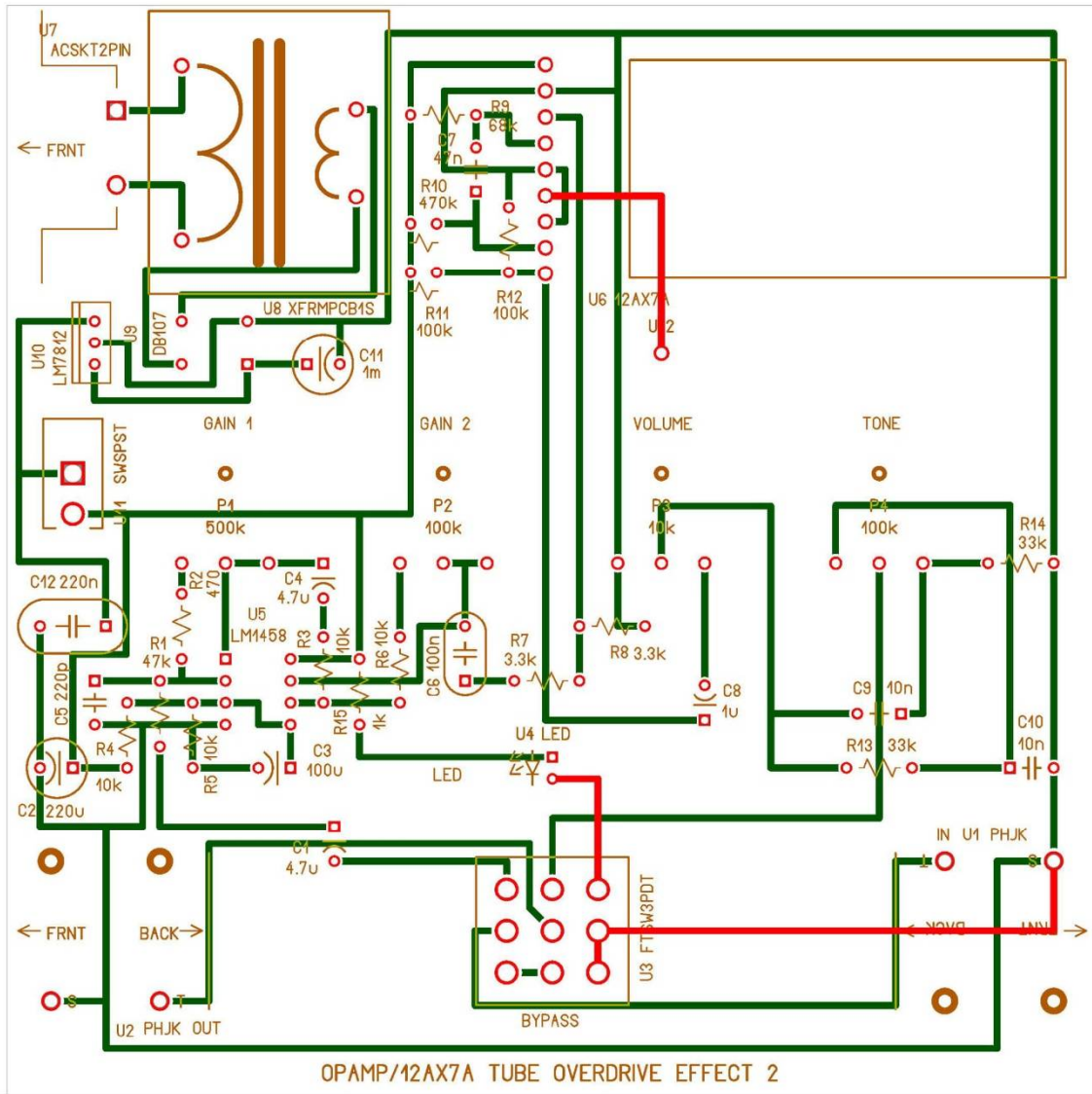

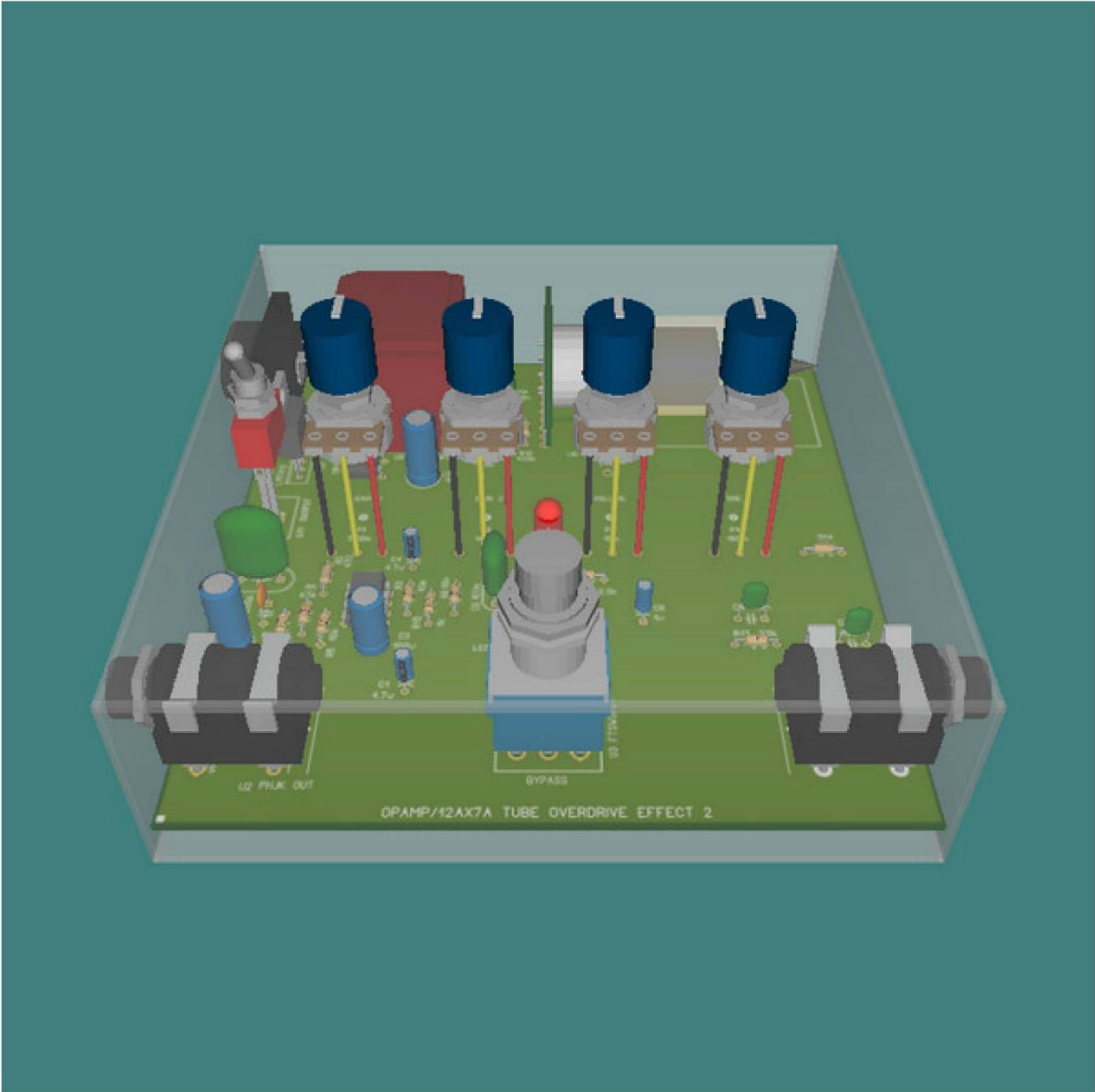

Attack/Decay Effect

Attack/Decay Effect Schematic

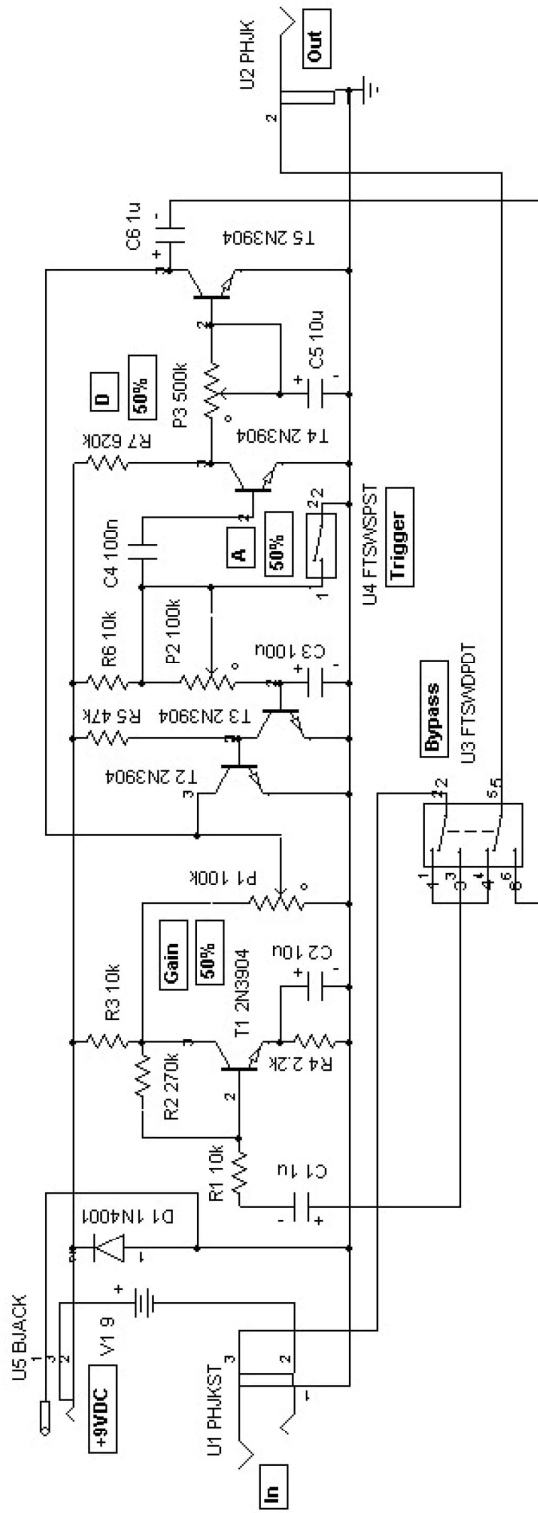

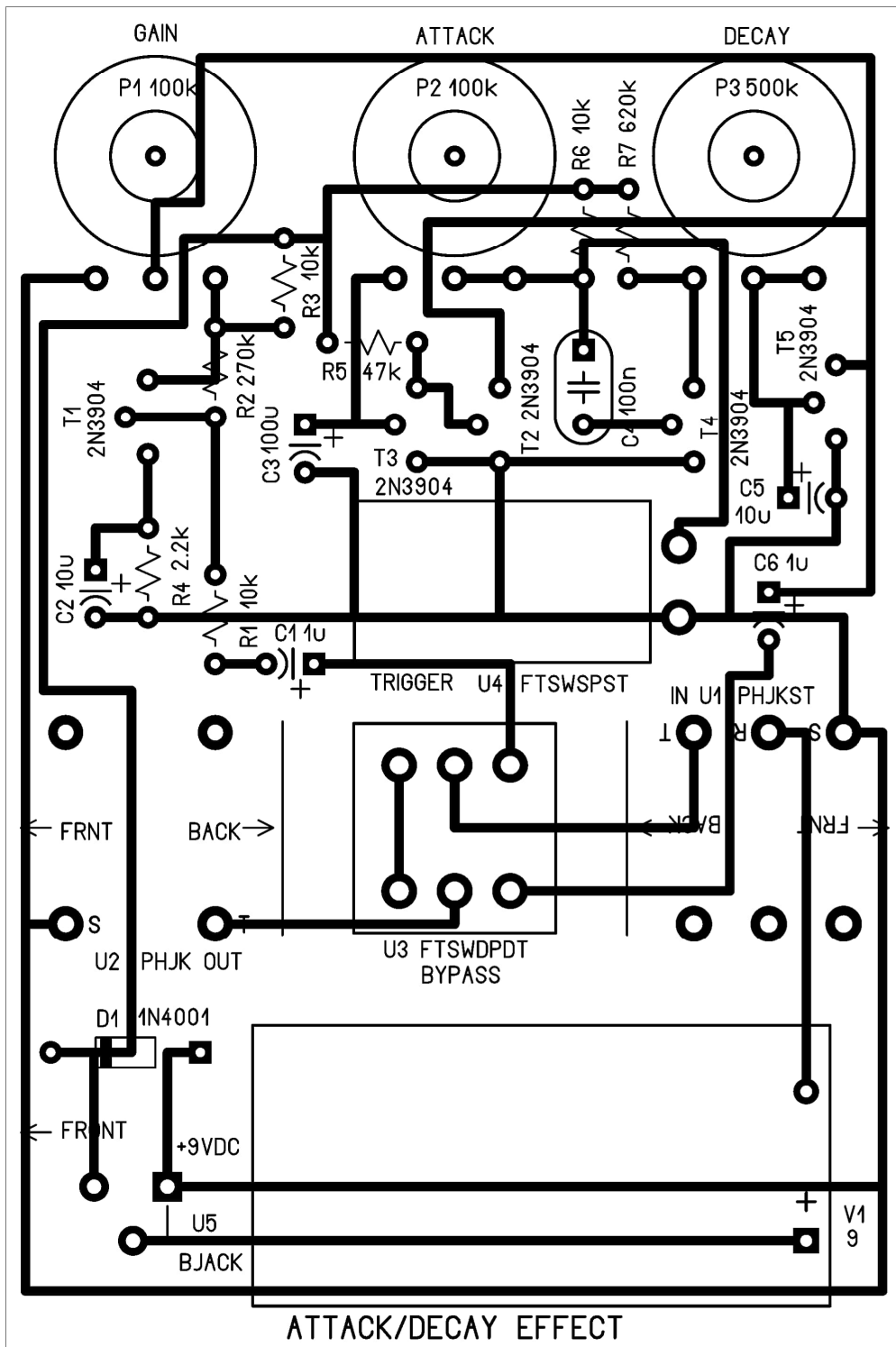

ATTACK/DECAY EFFECT

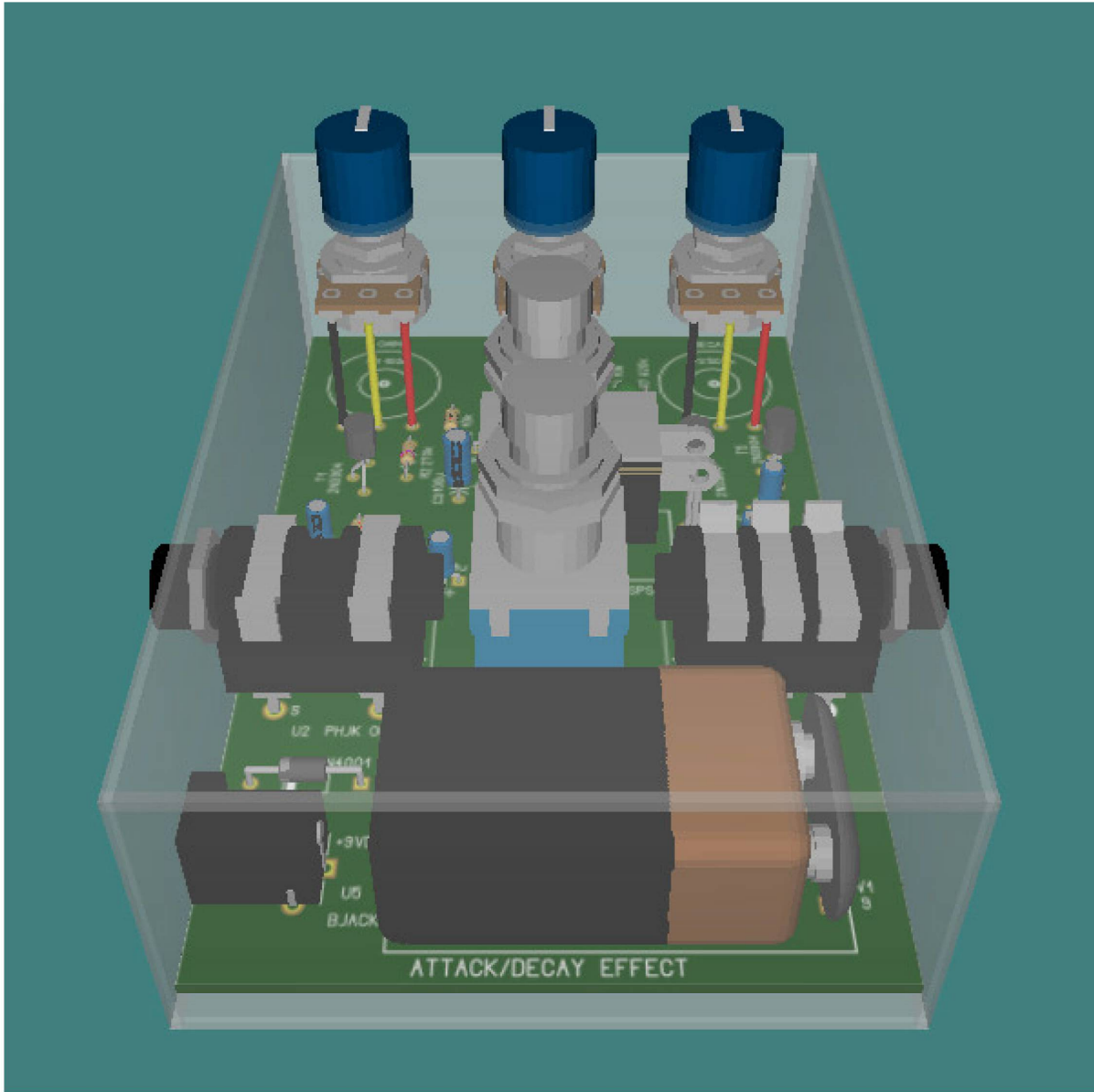

Voltage Controlled Bandpass Filter

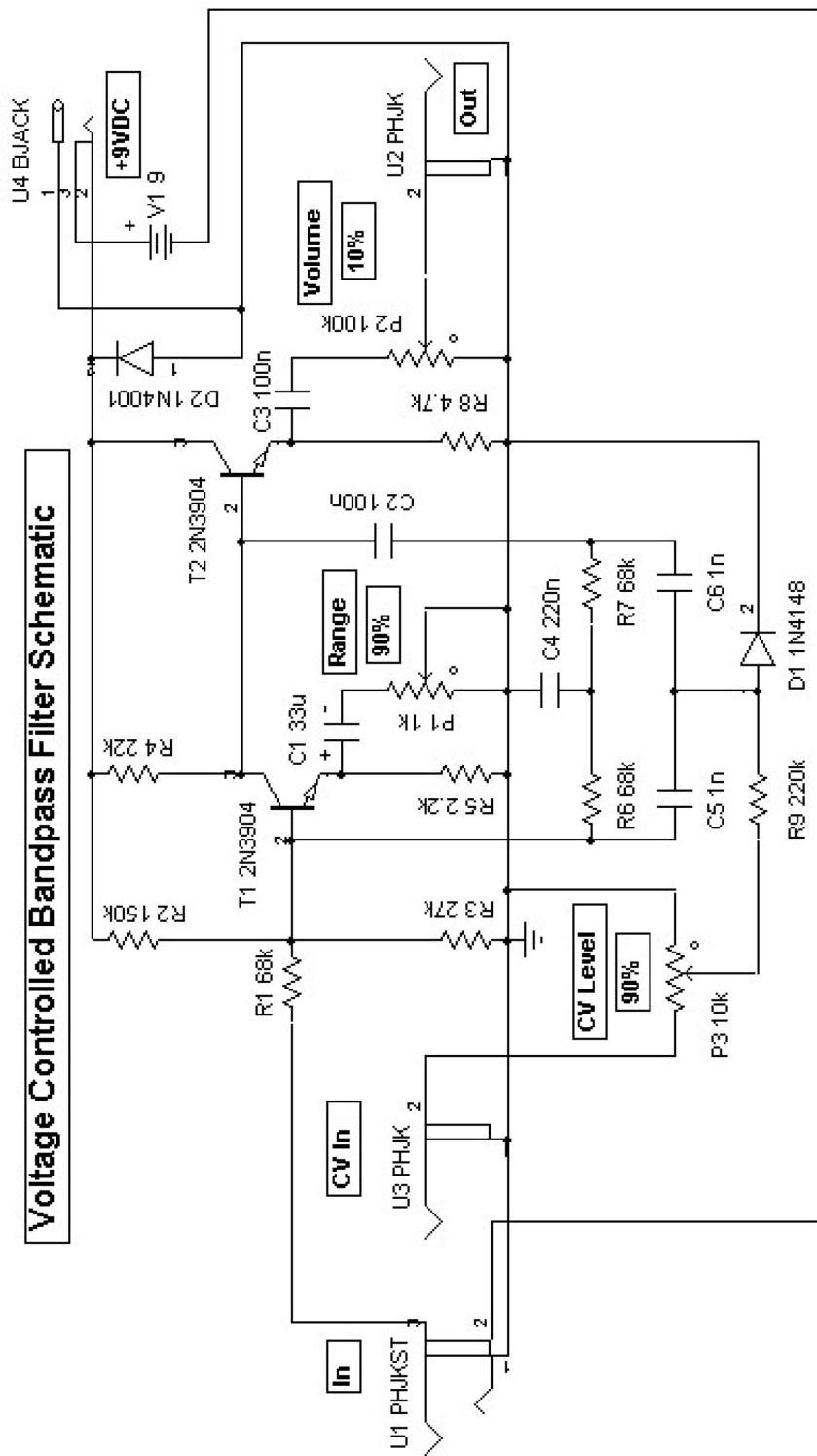

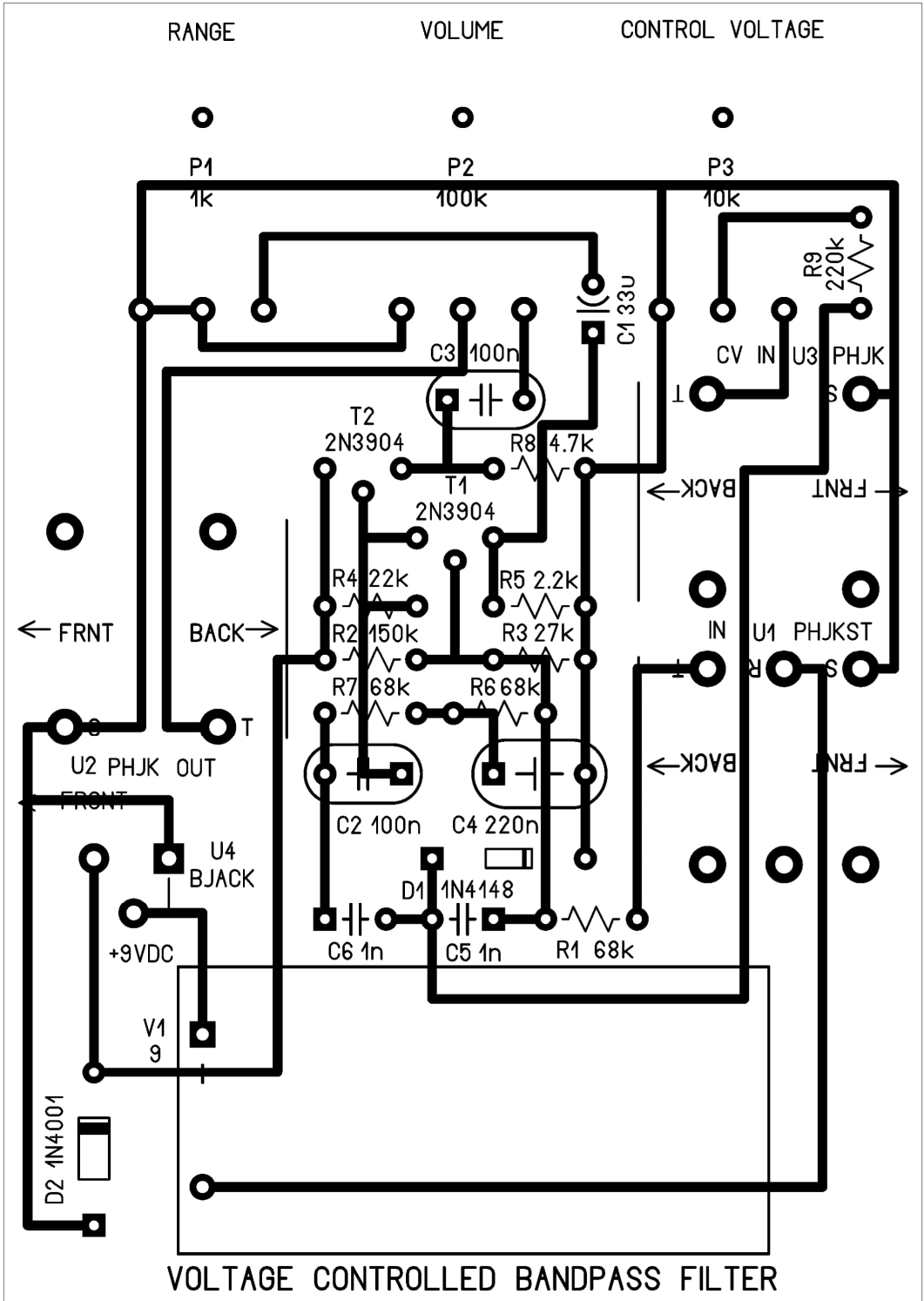

VOLTAGE CONTROLLED BANDPASS FILTER

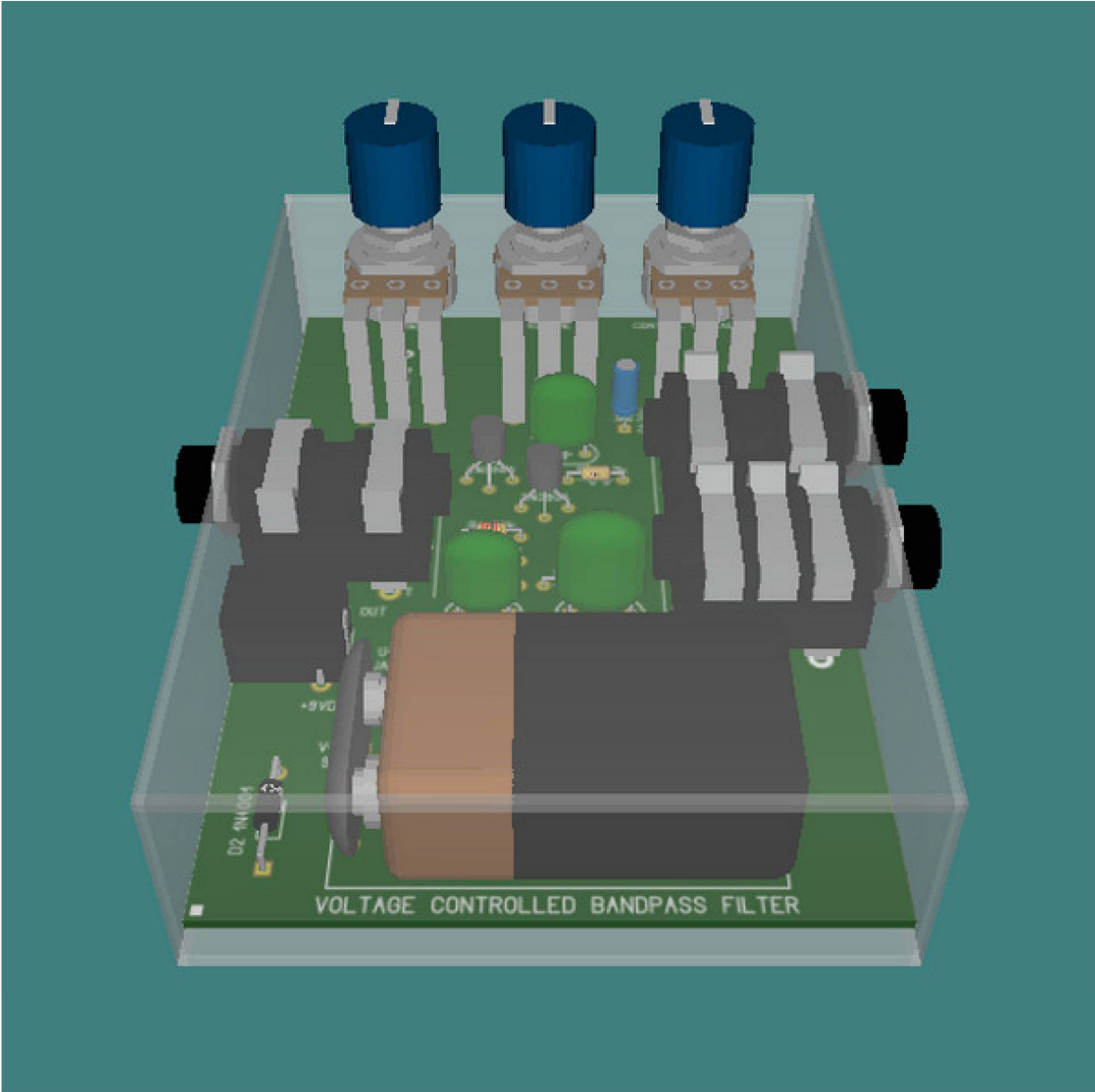

AutoWah Effect

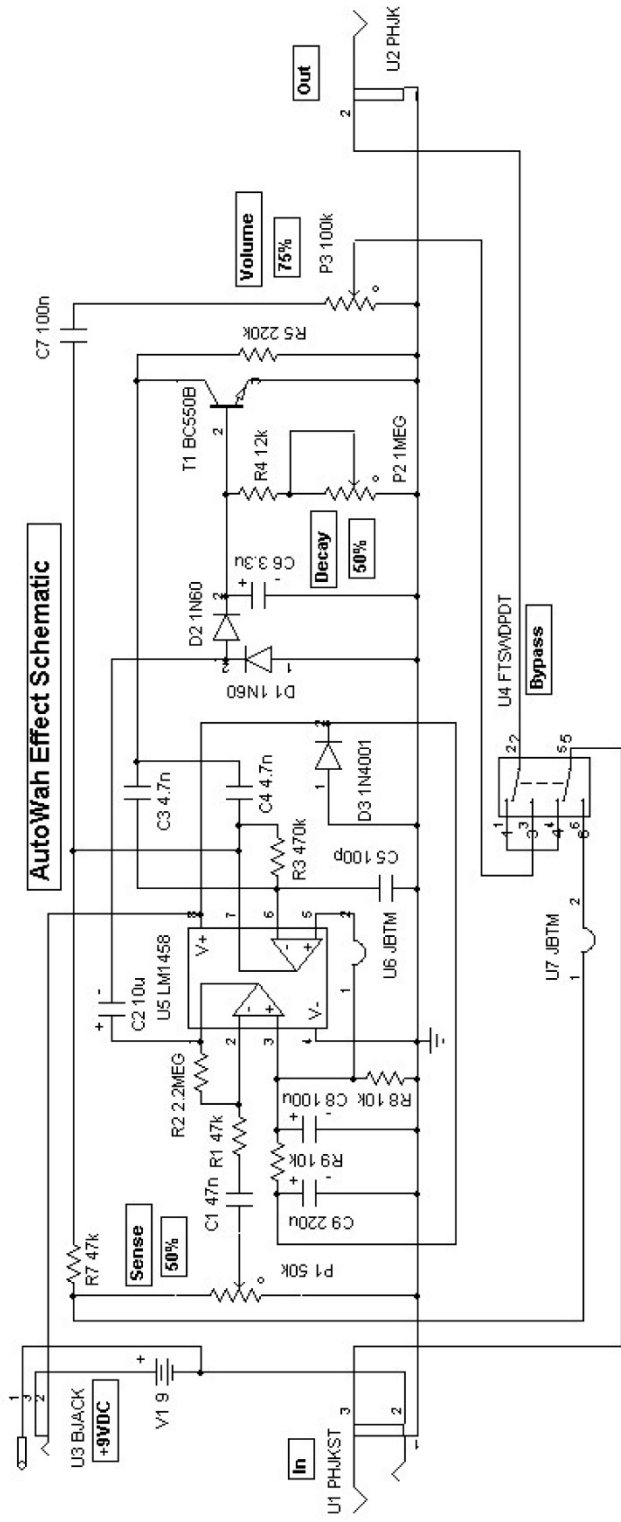

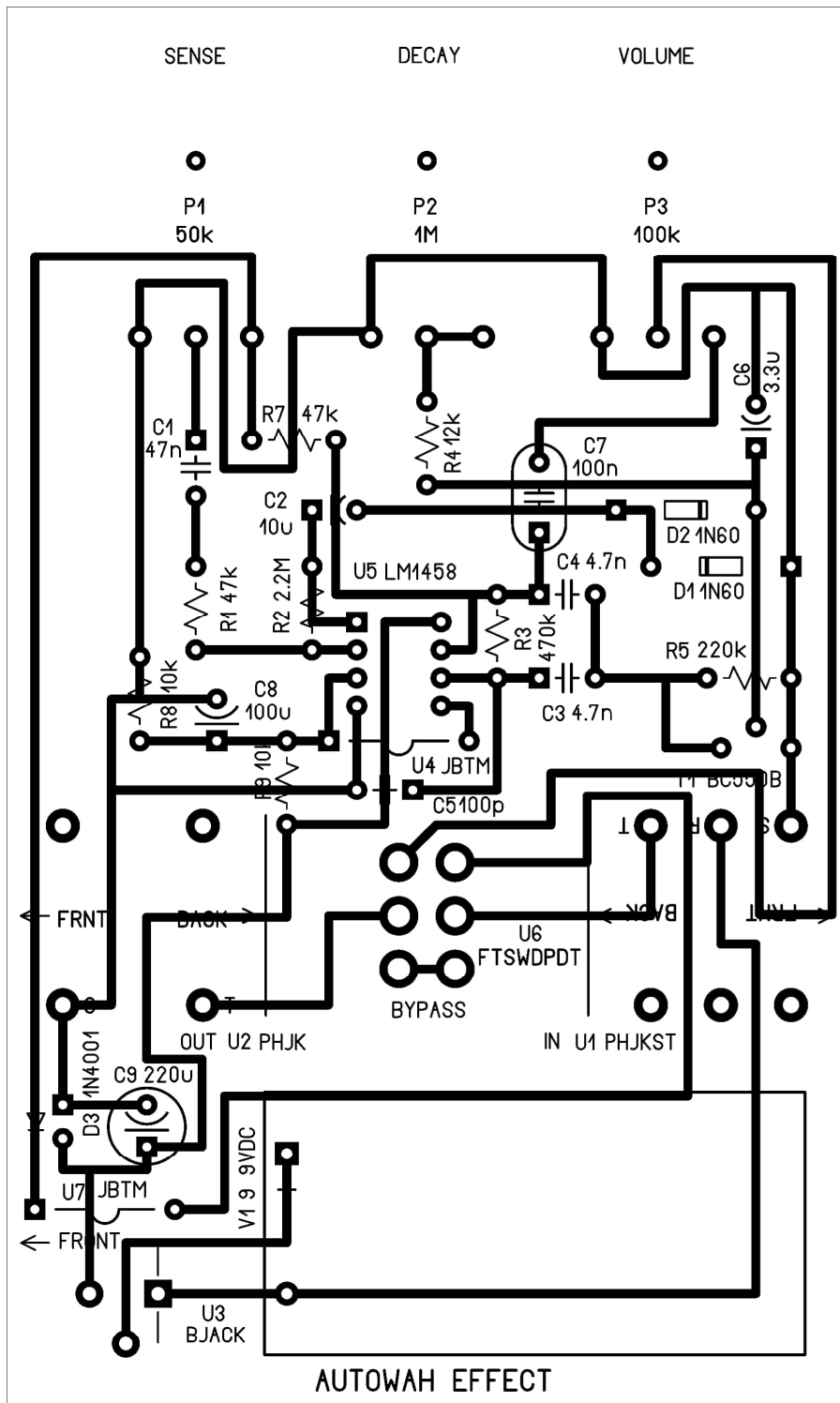

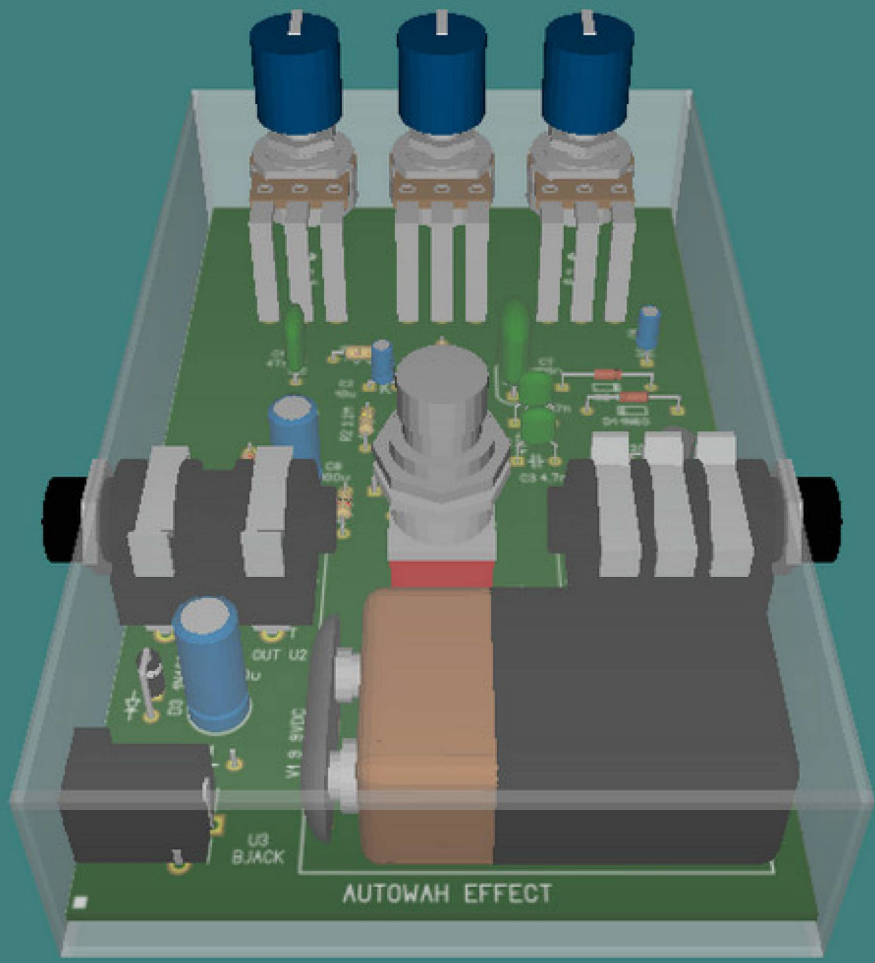

Wah Tone Effect

Wah Tone Effect Schematic

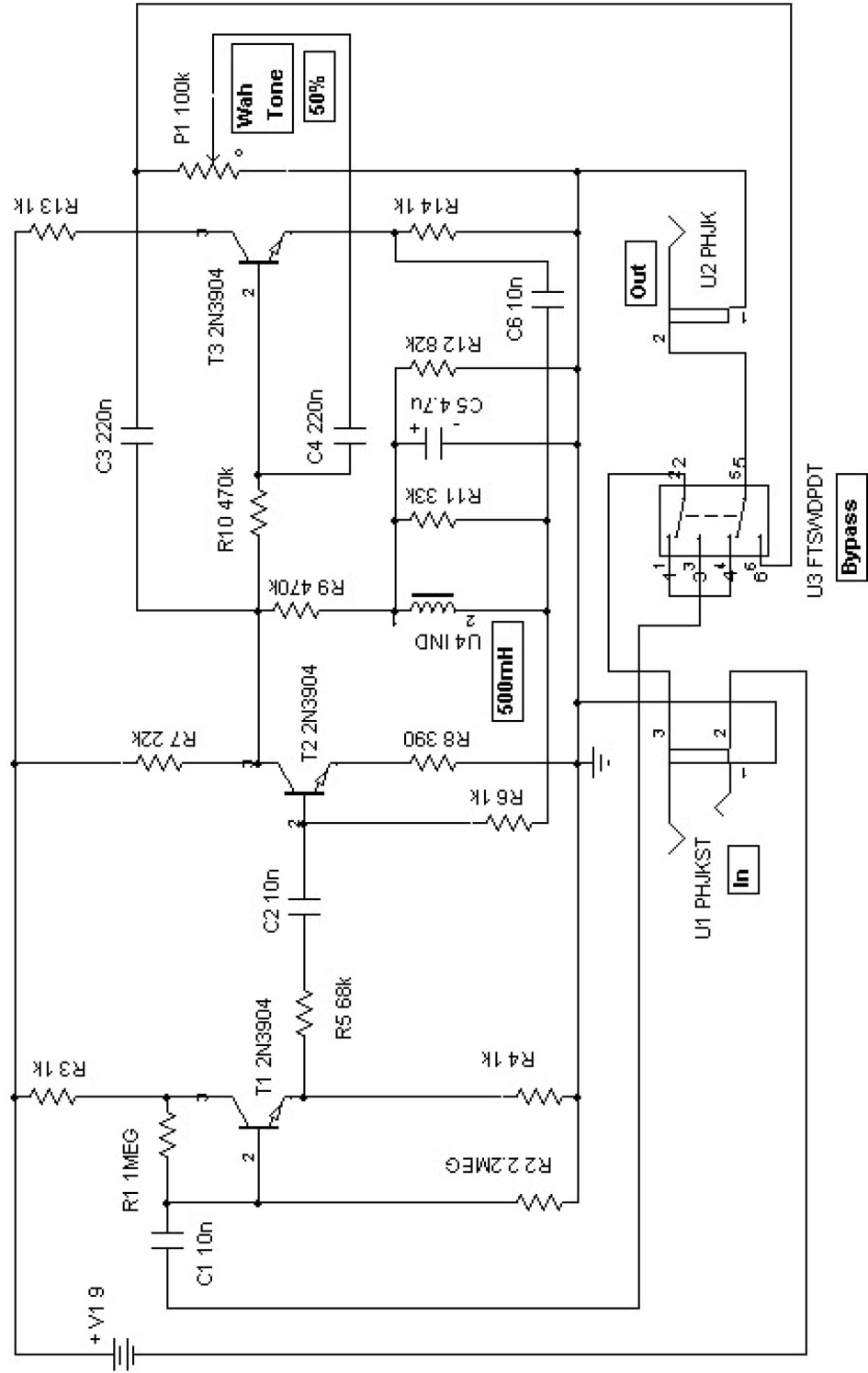

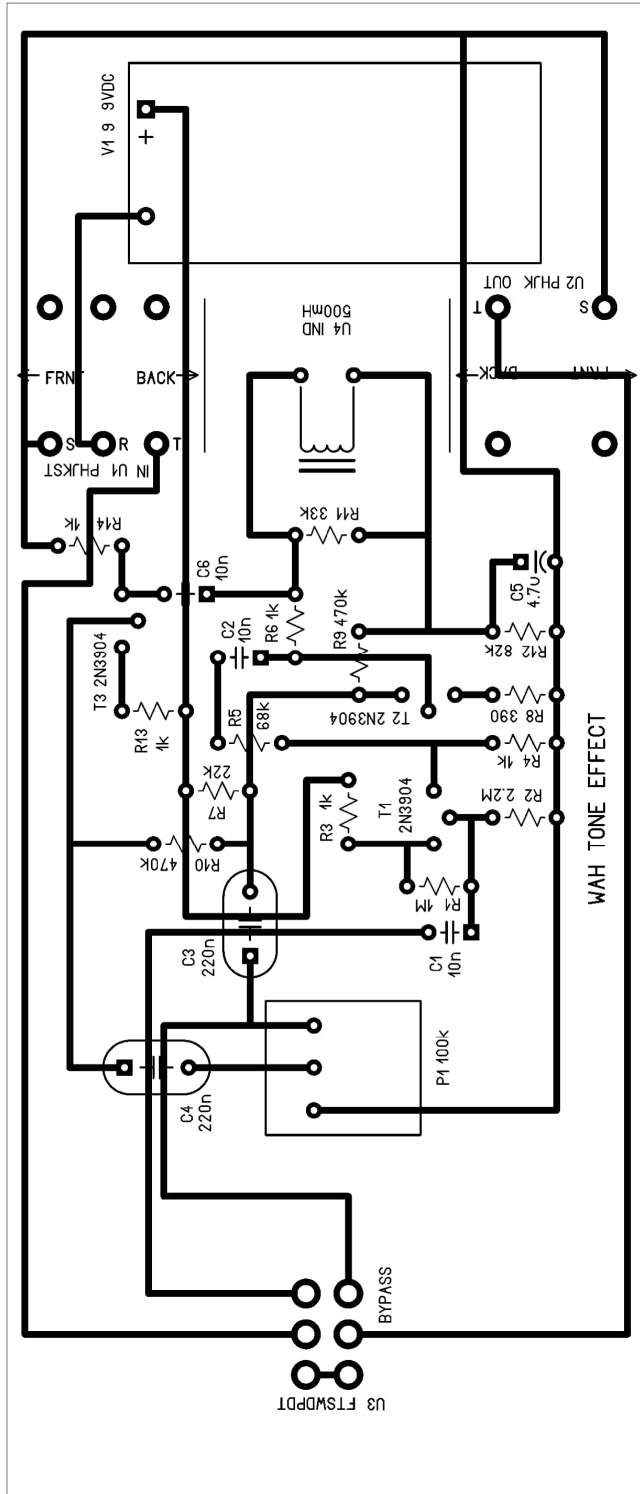

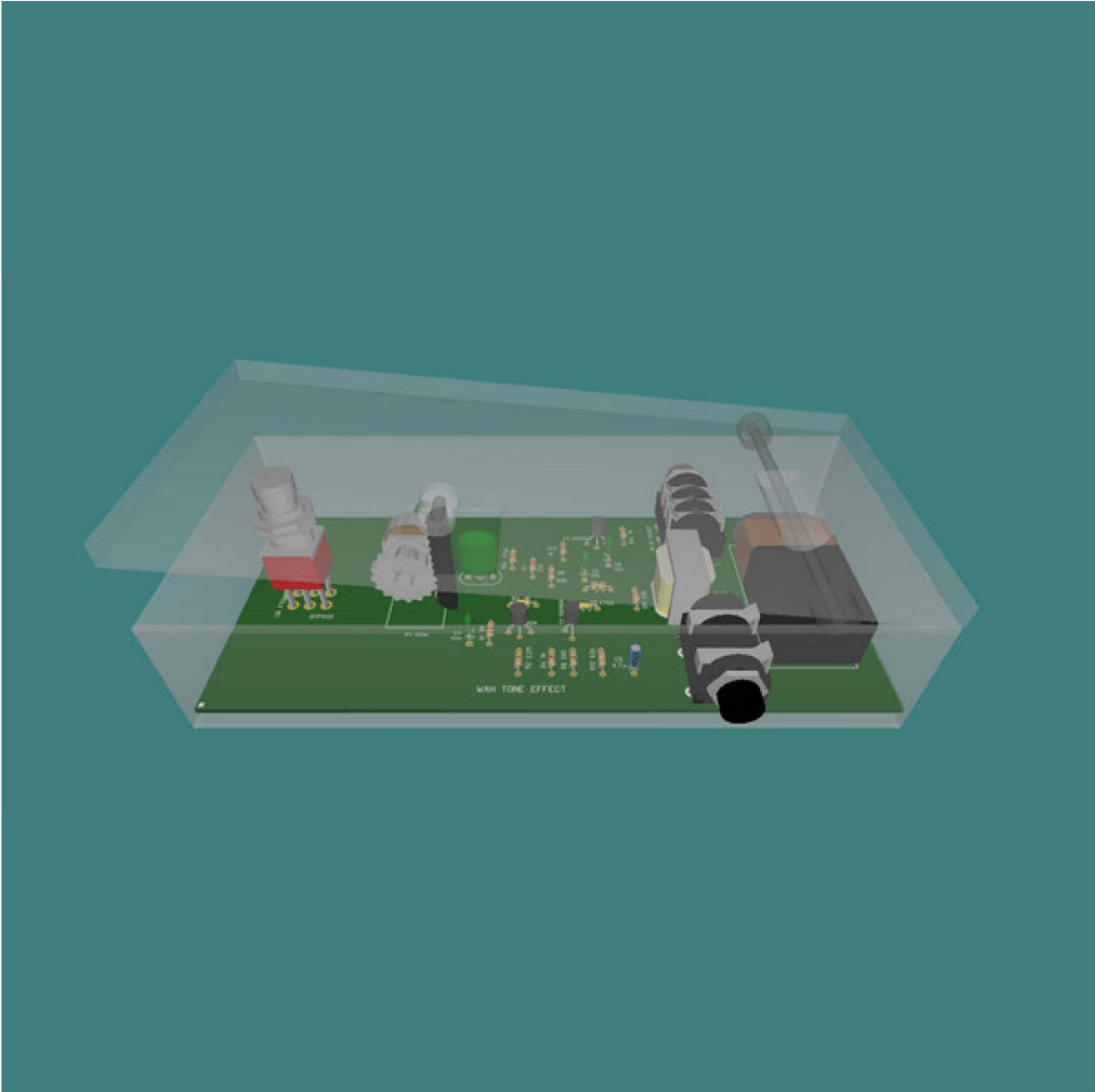

LM1496 Audio Frequency Doubler

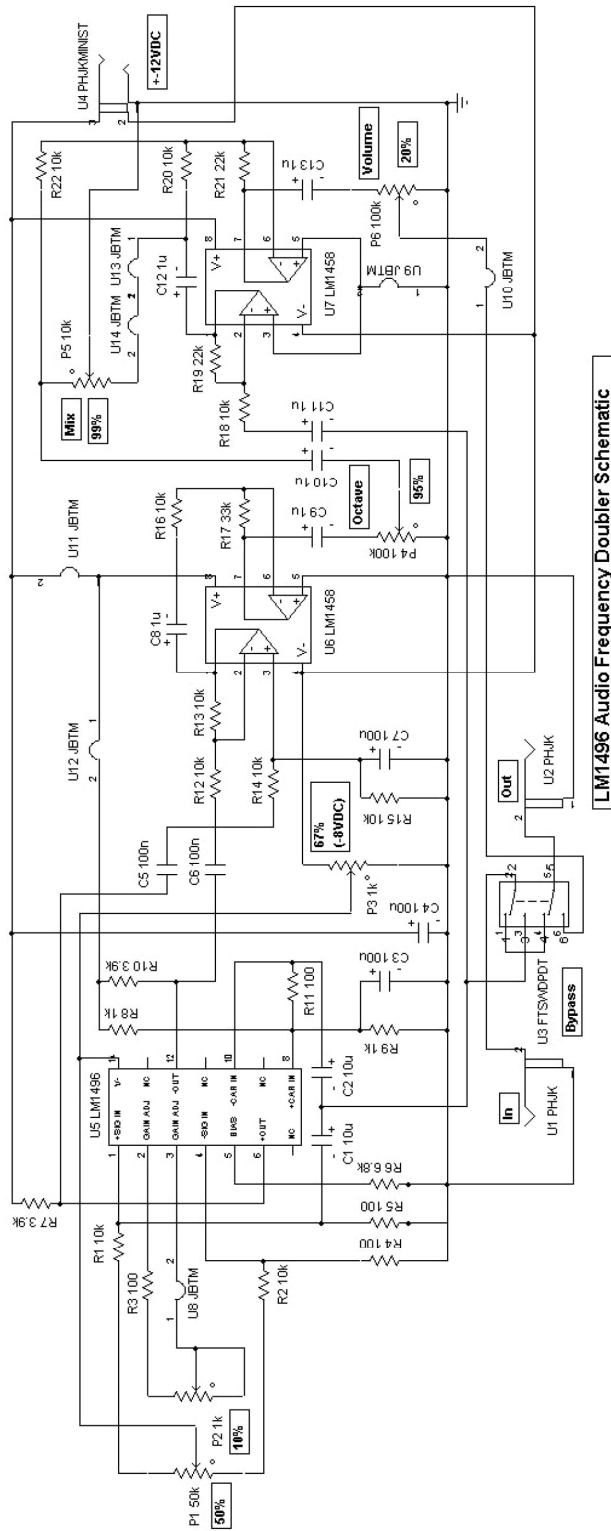

LM1496 Audio Frequency Doubler Schematic

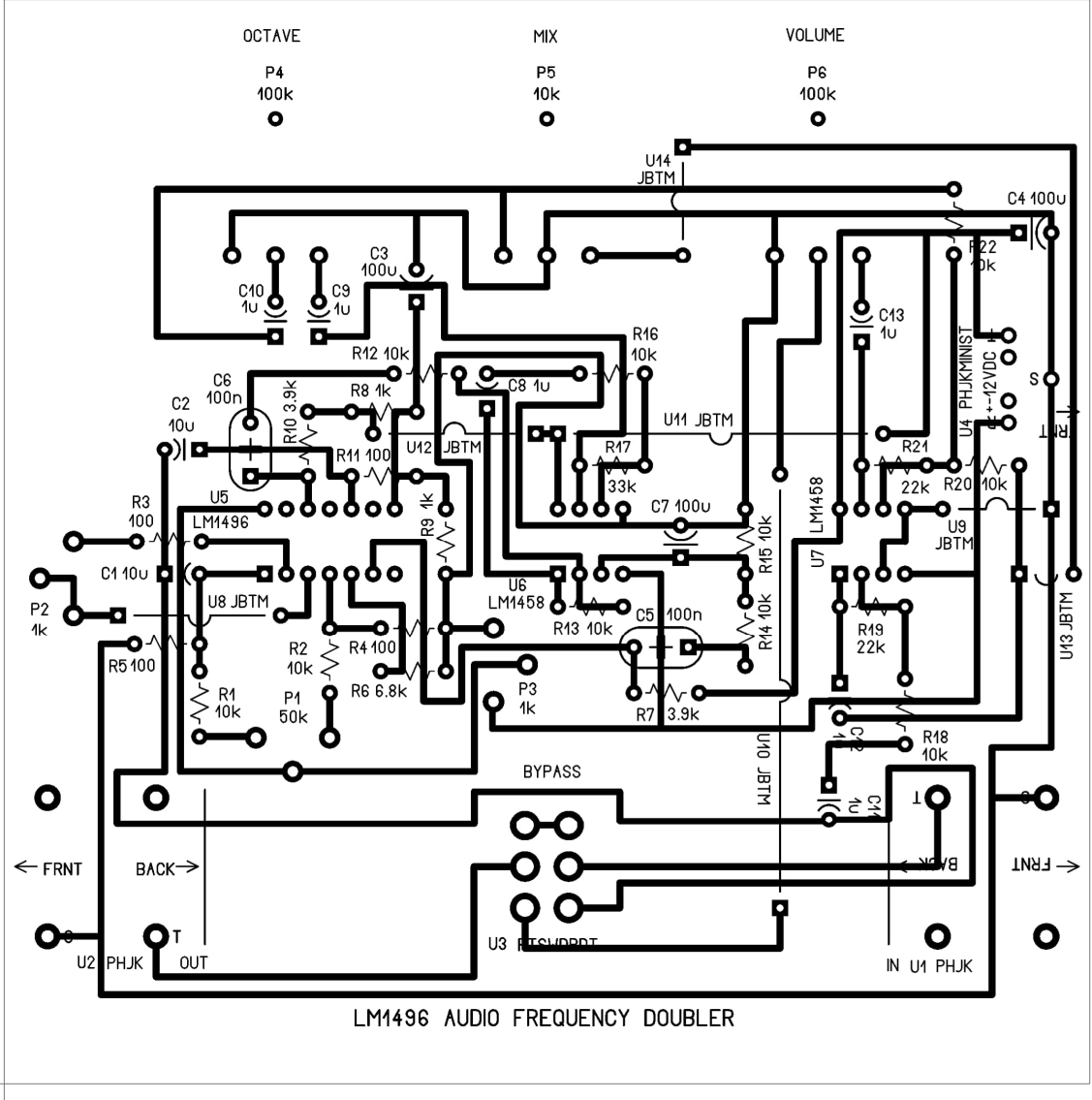

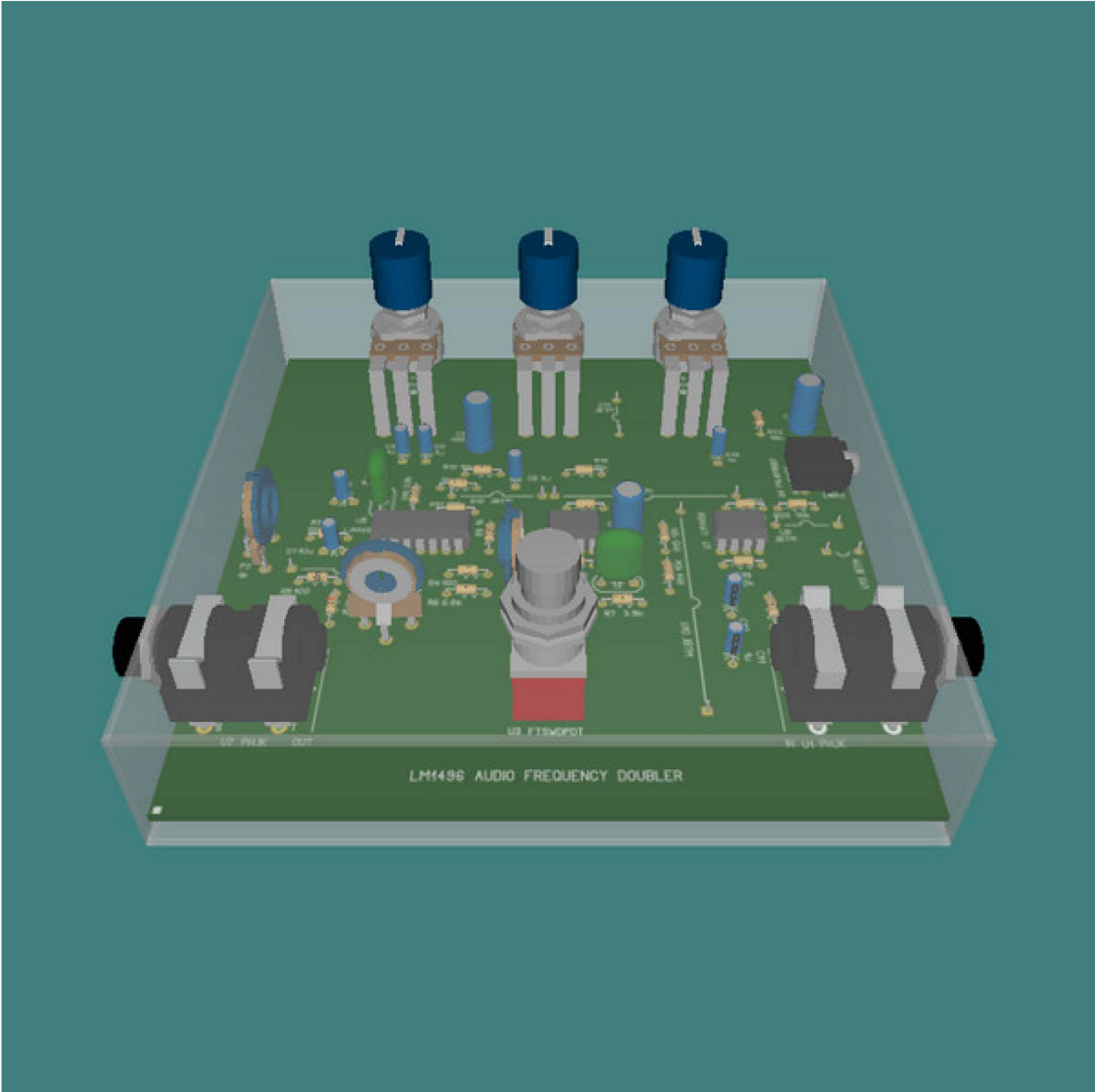

AD633 Ring Modulator

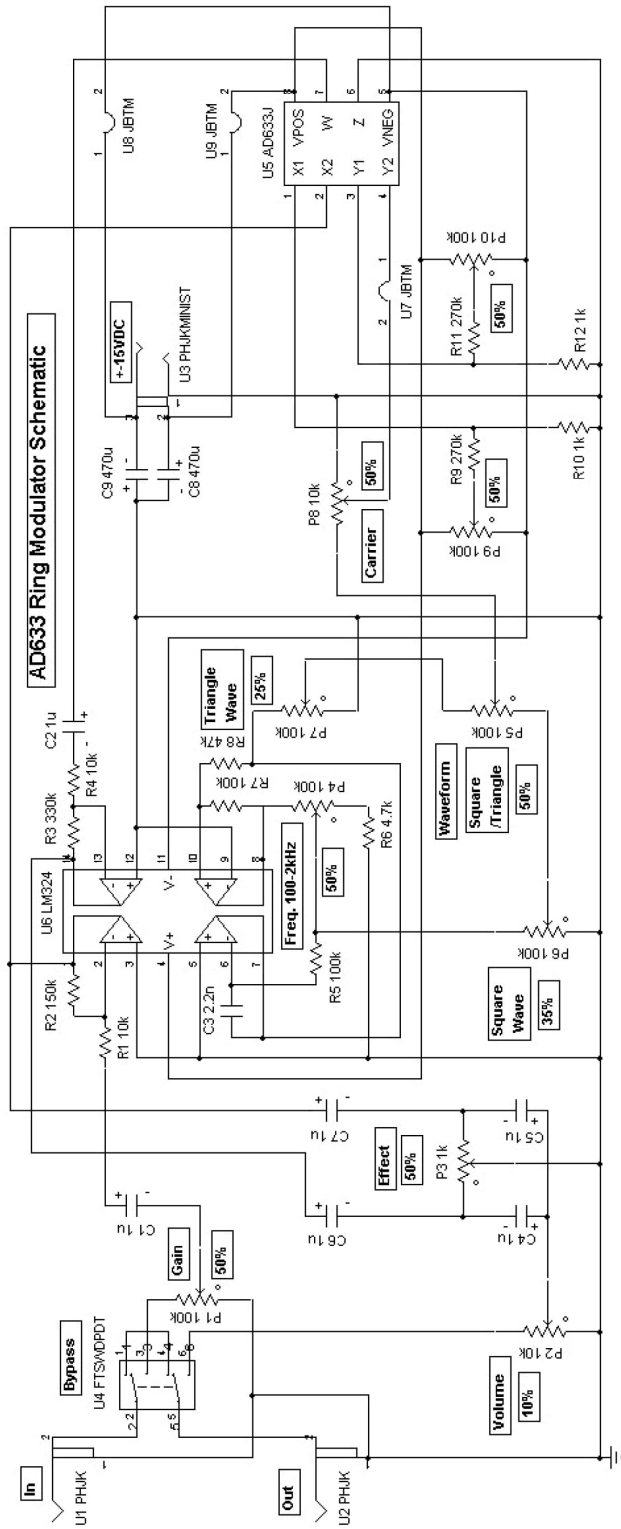

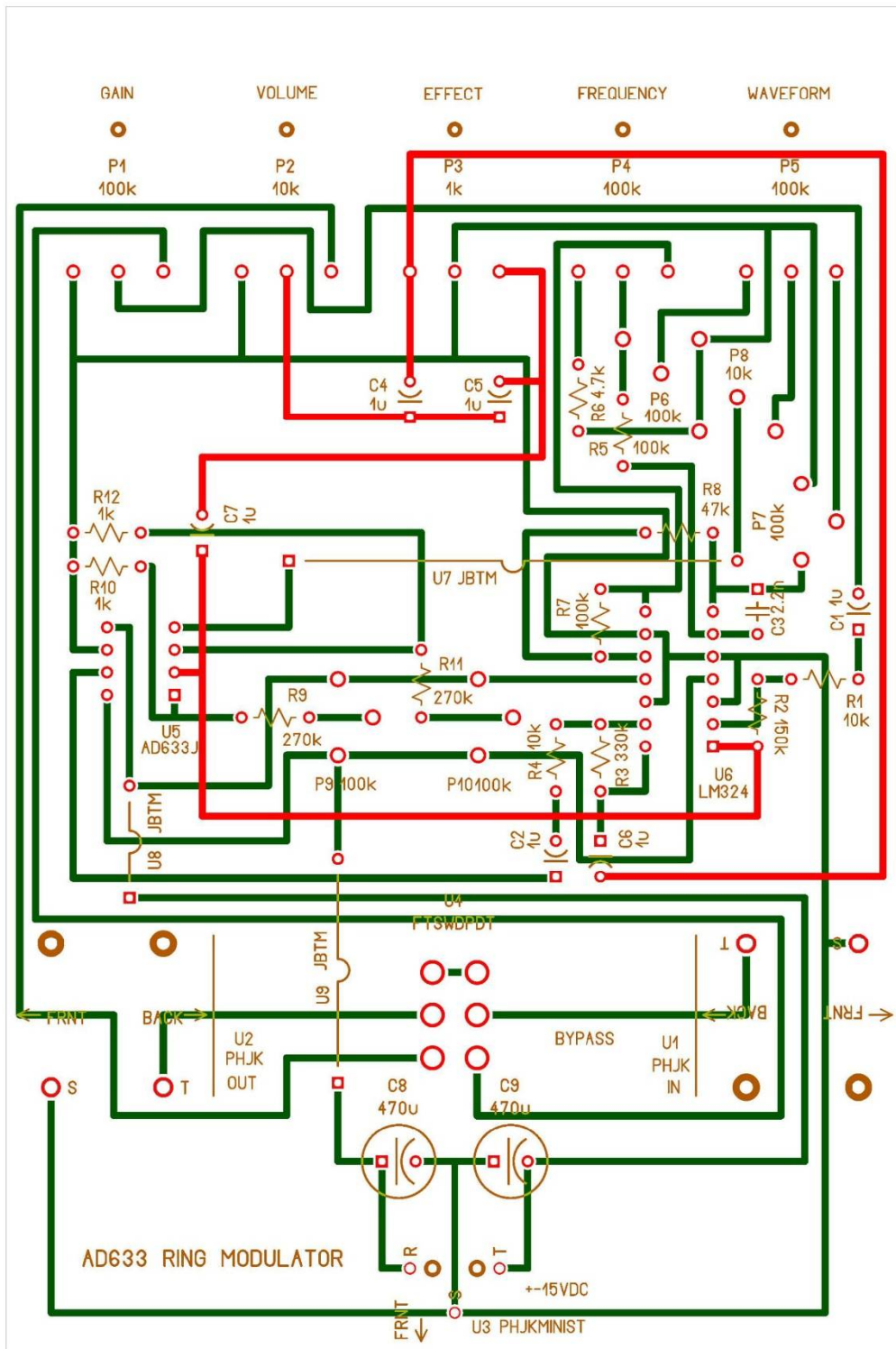

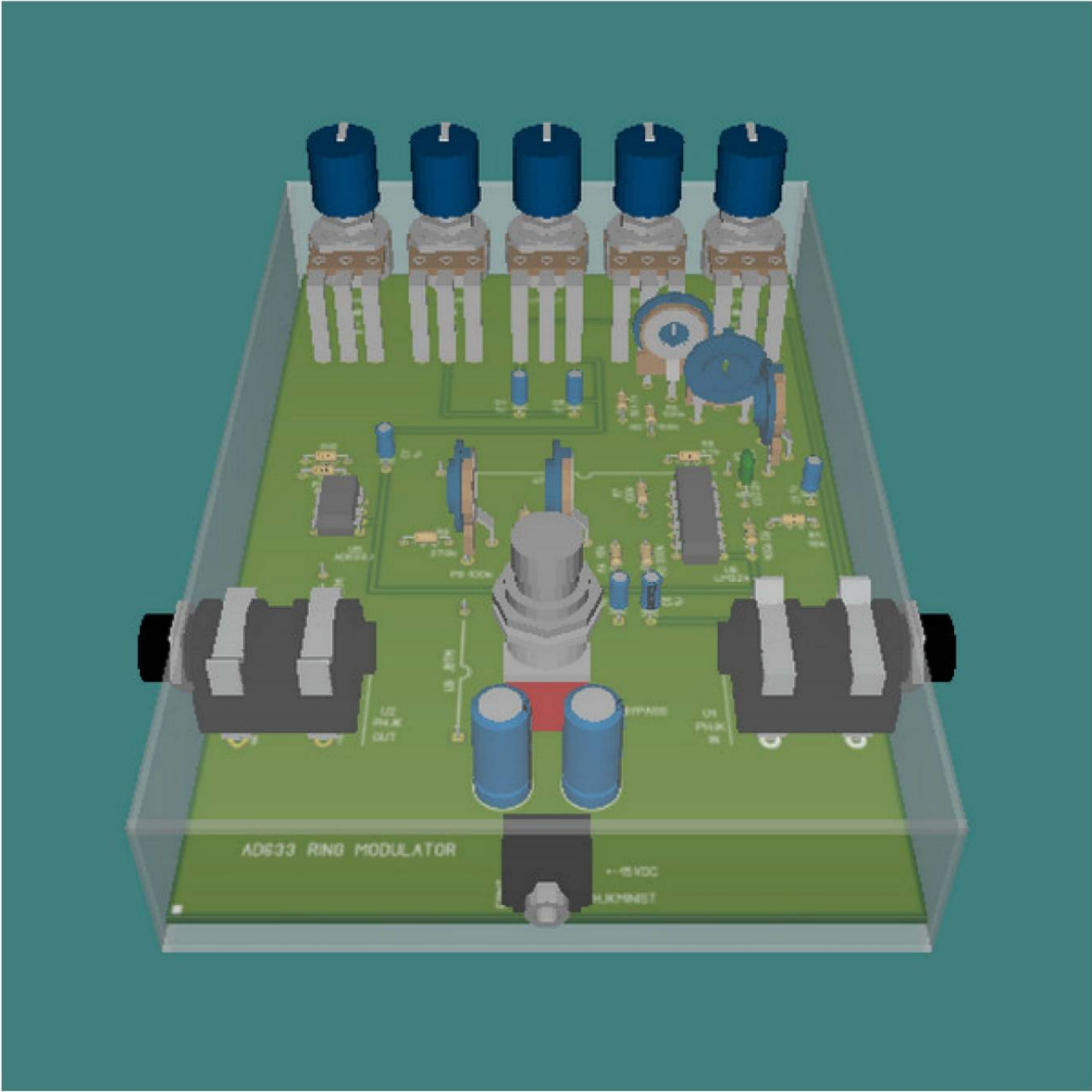

LM386 Square Wave Oscillator (w/Speaker)

LM386 Square Wave Oscillator Schematic

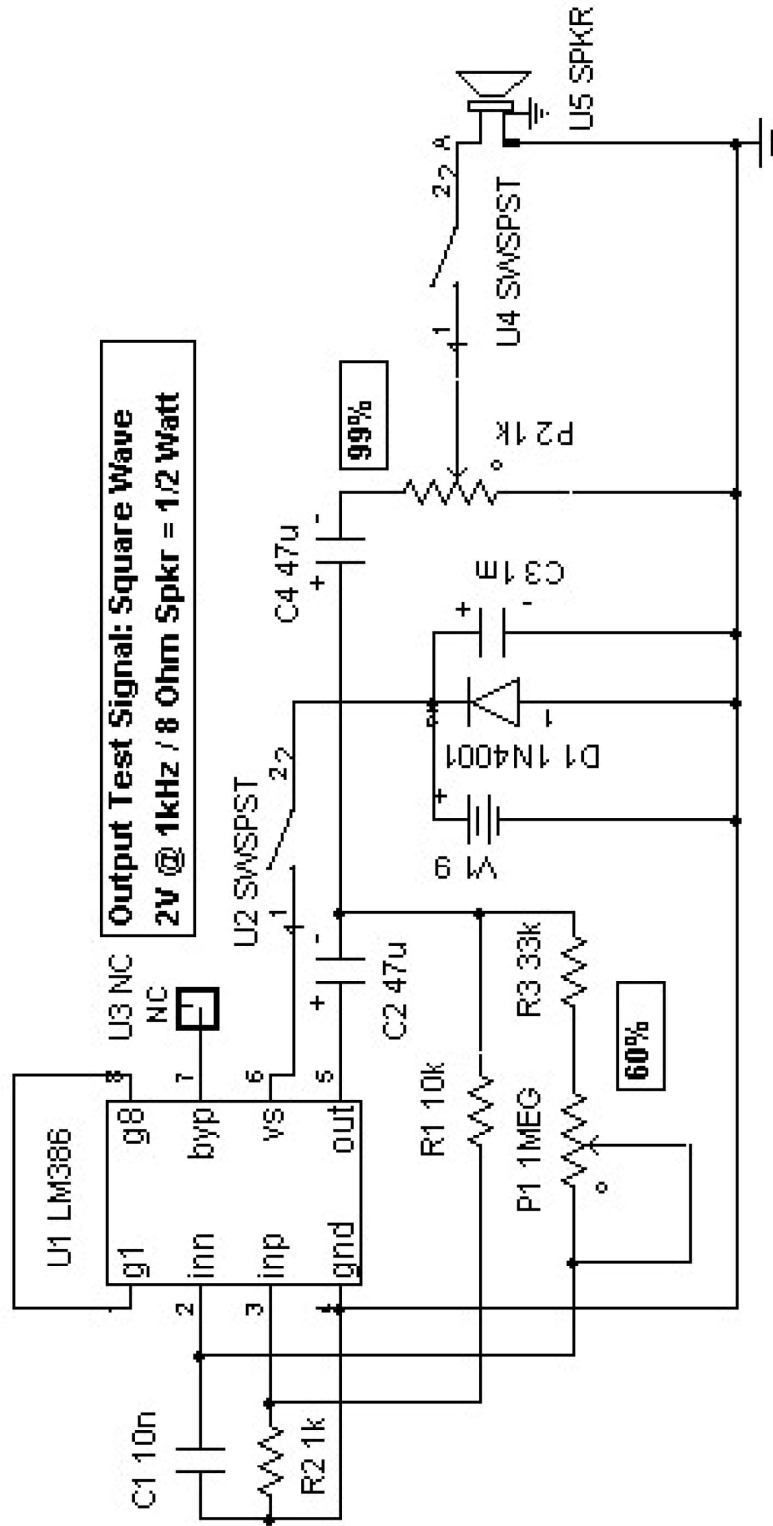

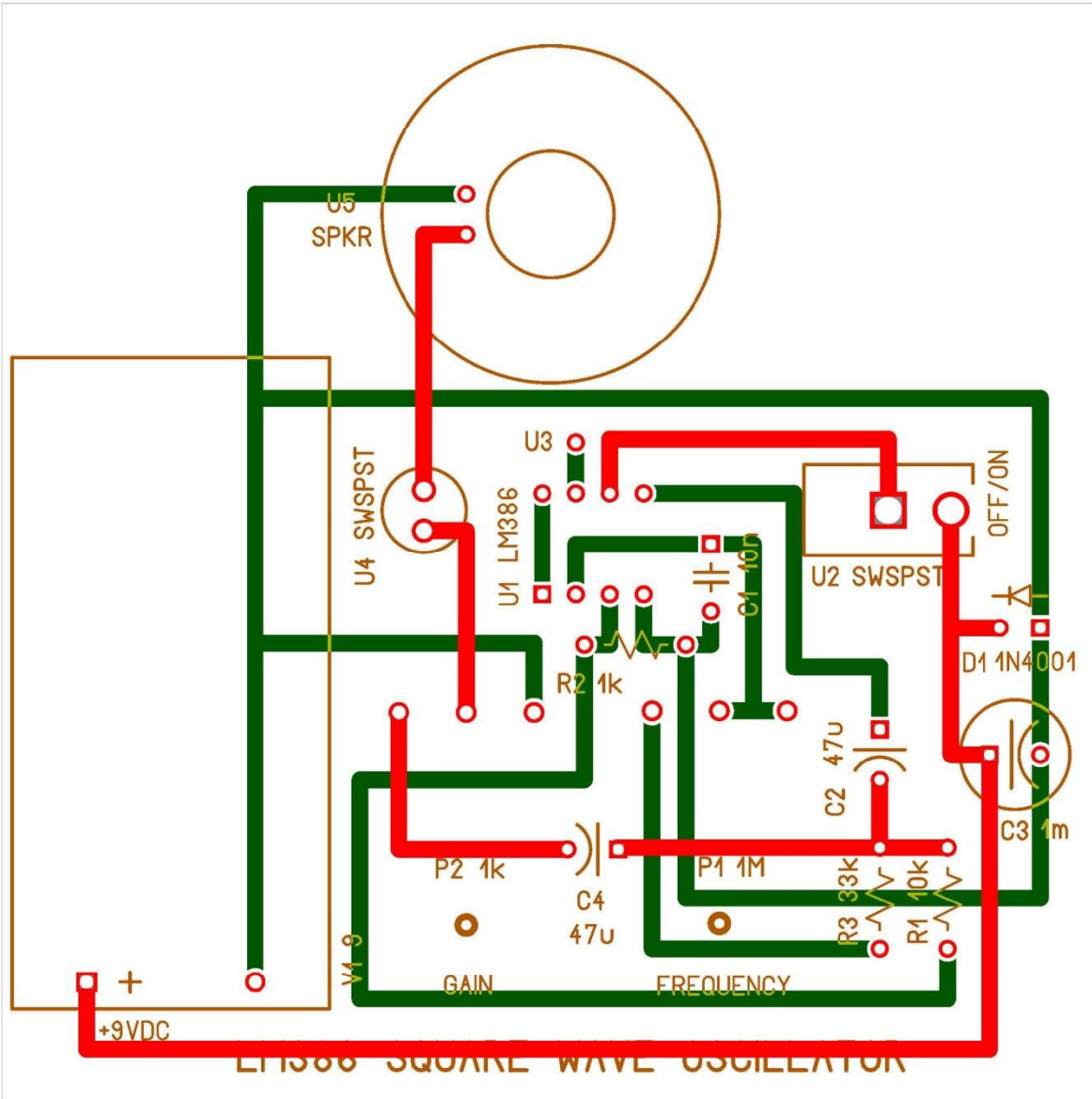

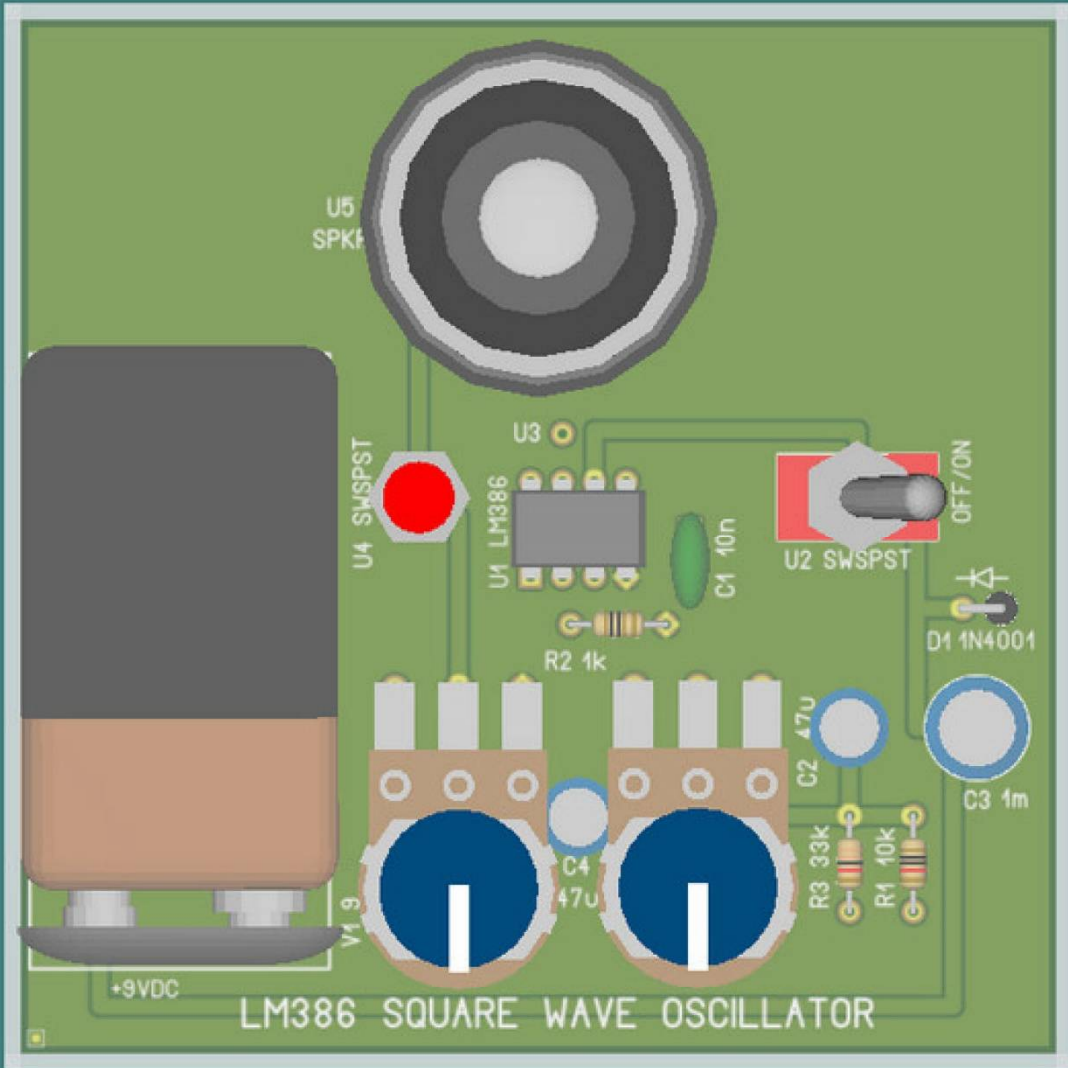

LM386 Square Wave Oscillator PCB

LM386 Square Wave Oscillator PCB Schematic

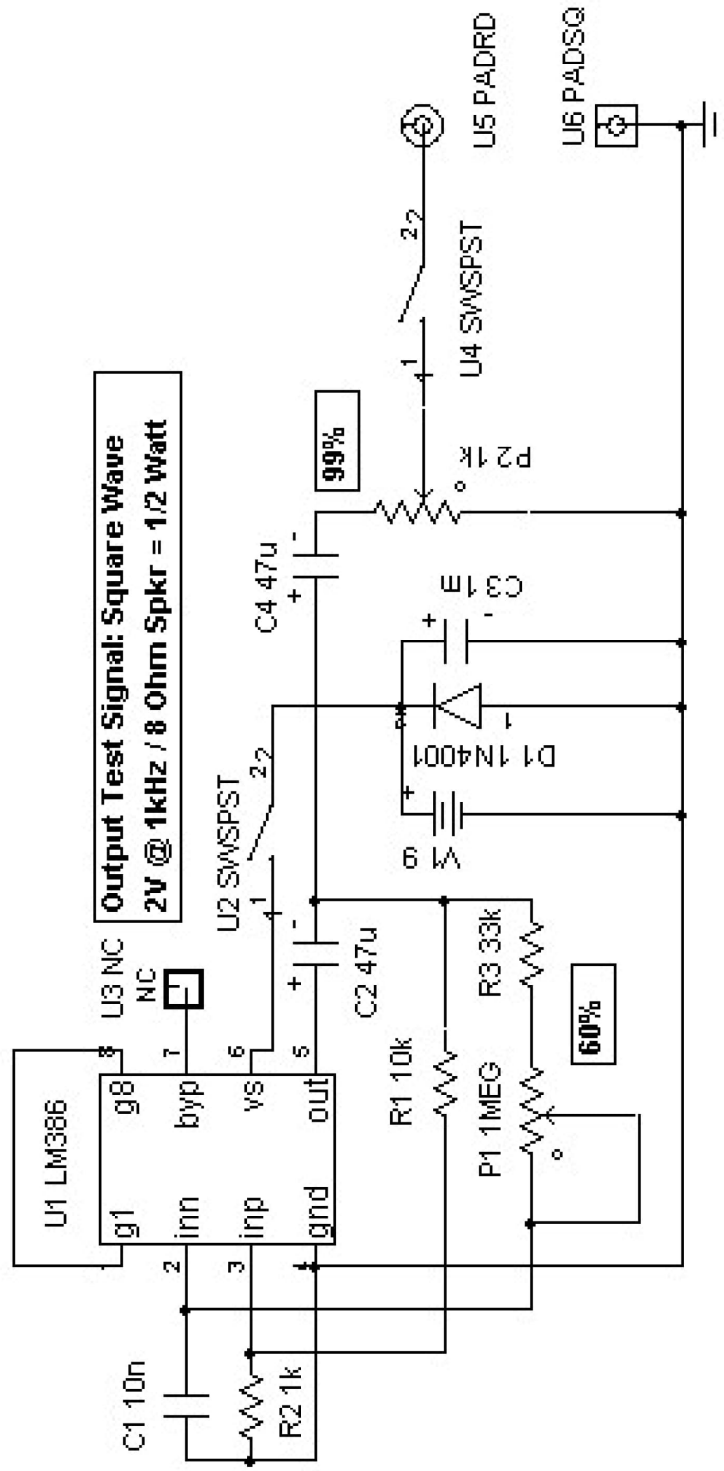

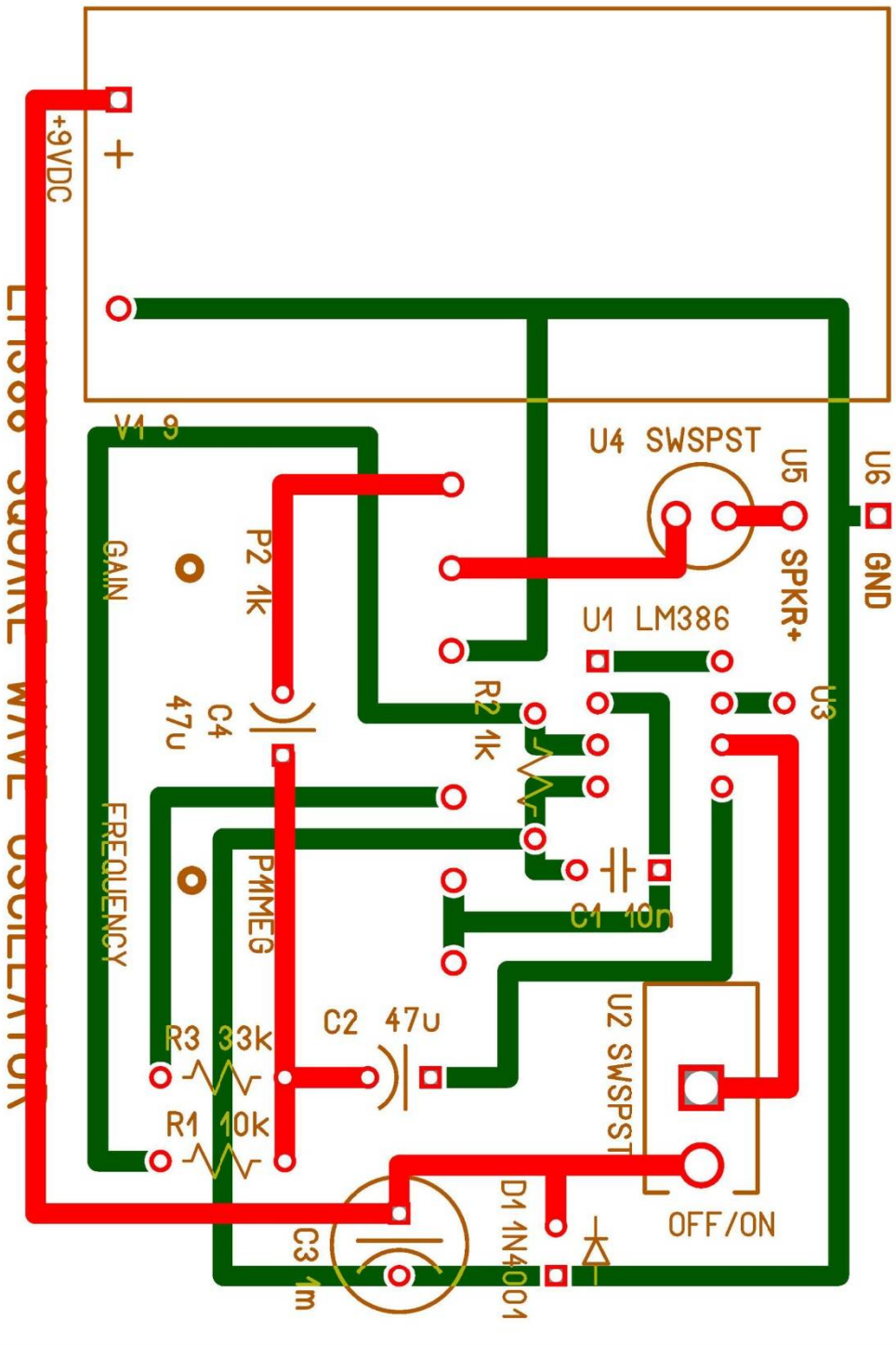

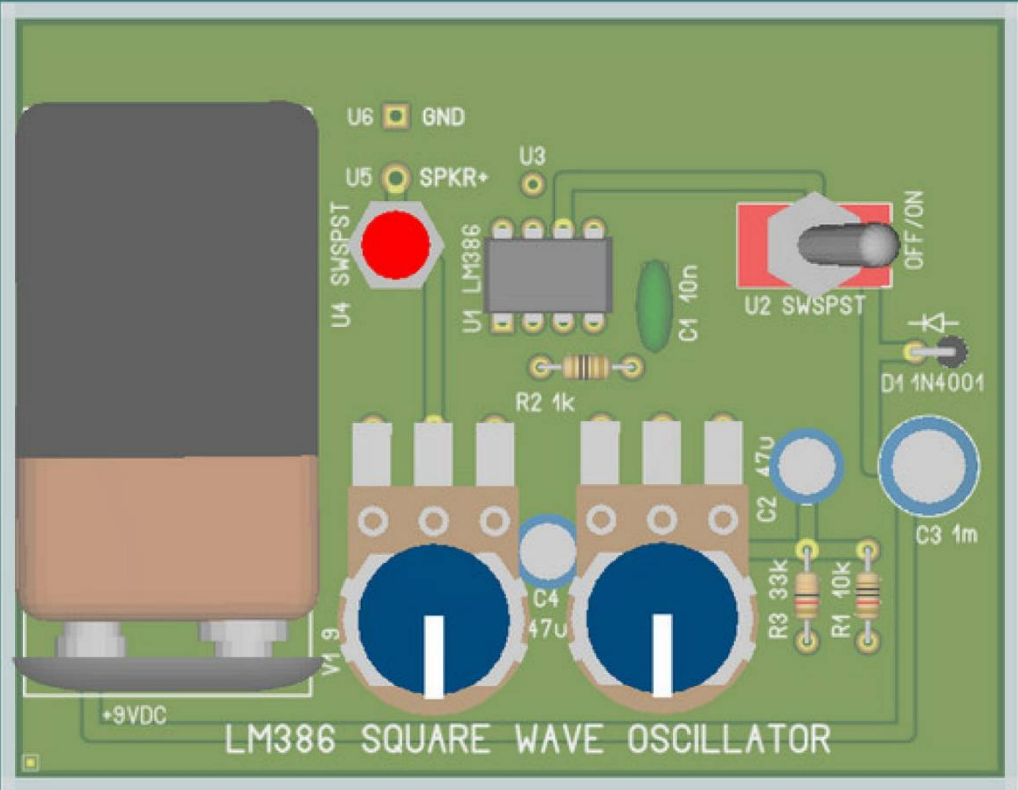

2 Transistor Sine Wave Audio Signal Generator

2 Transistor Sine Wave Audio Signal Generator Schematic

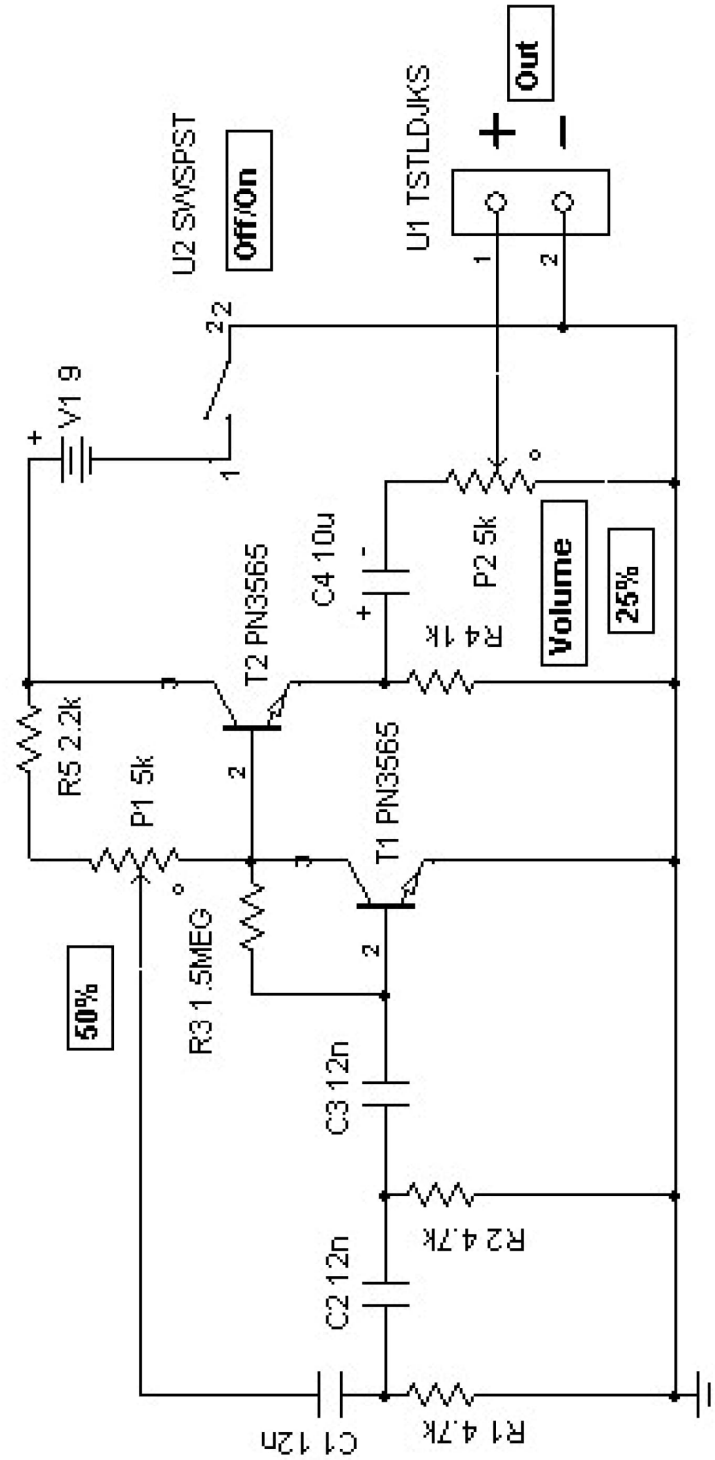

2 TRANSISTOR SINE WAVE AUDIO SIGNAL GENERATOR

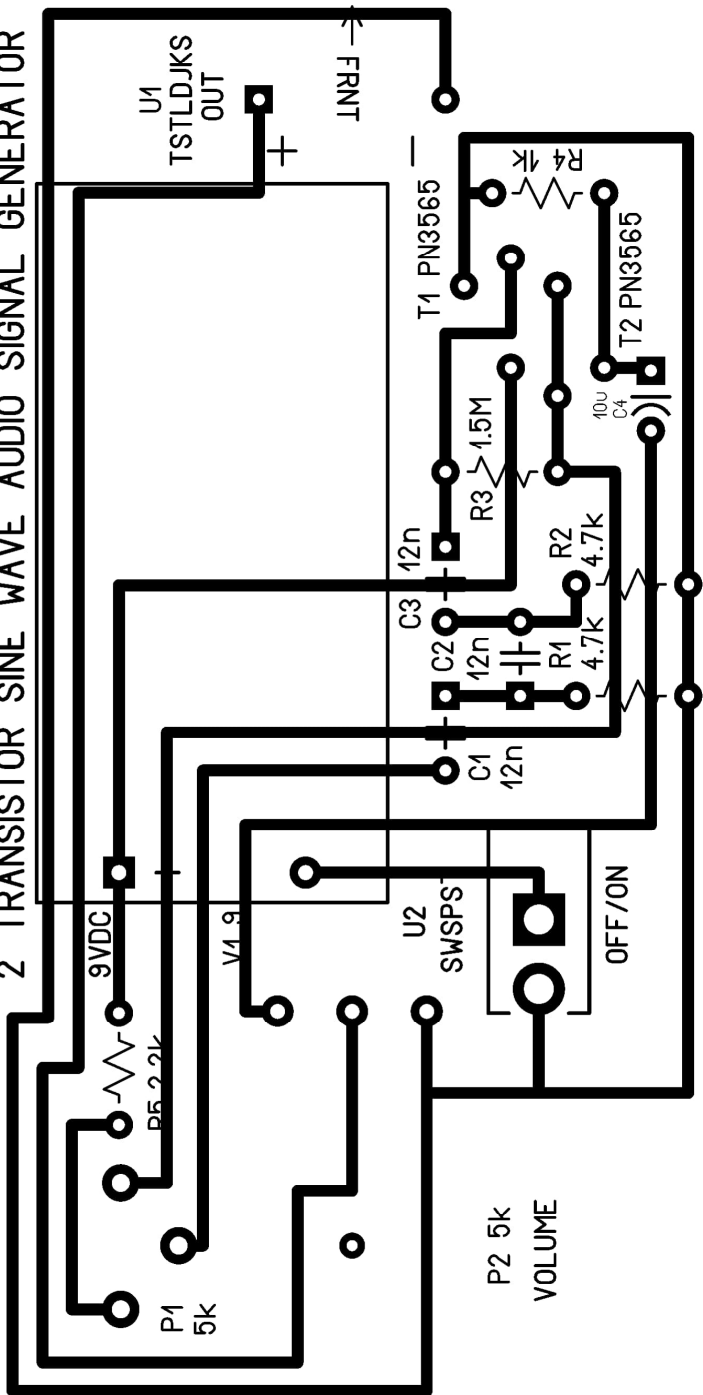

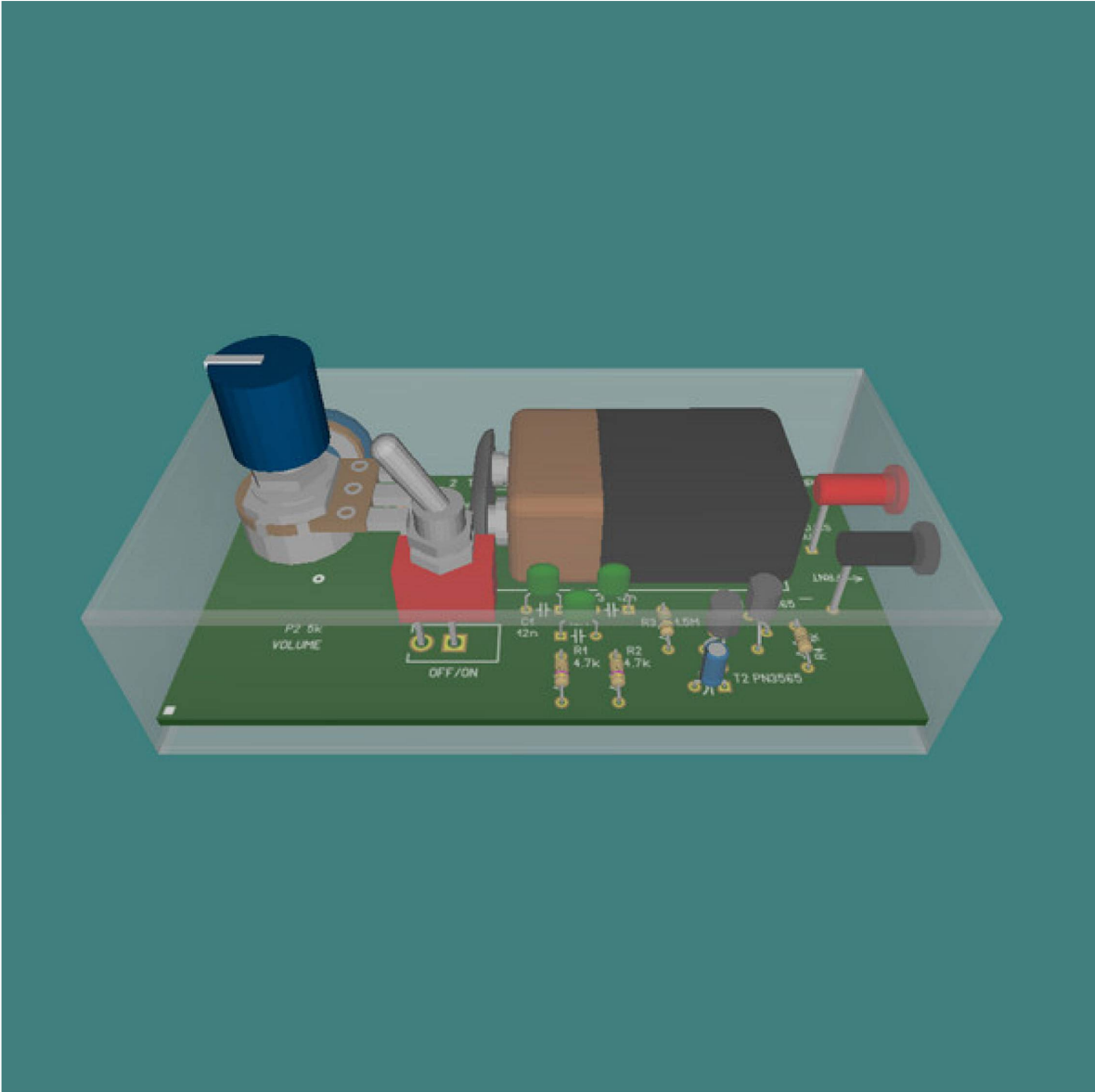

Audio Signal Injector

Audio Signal Injector Schematic

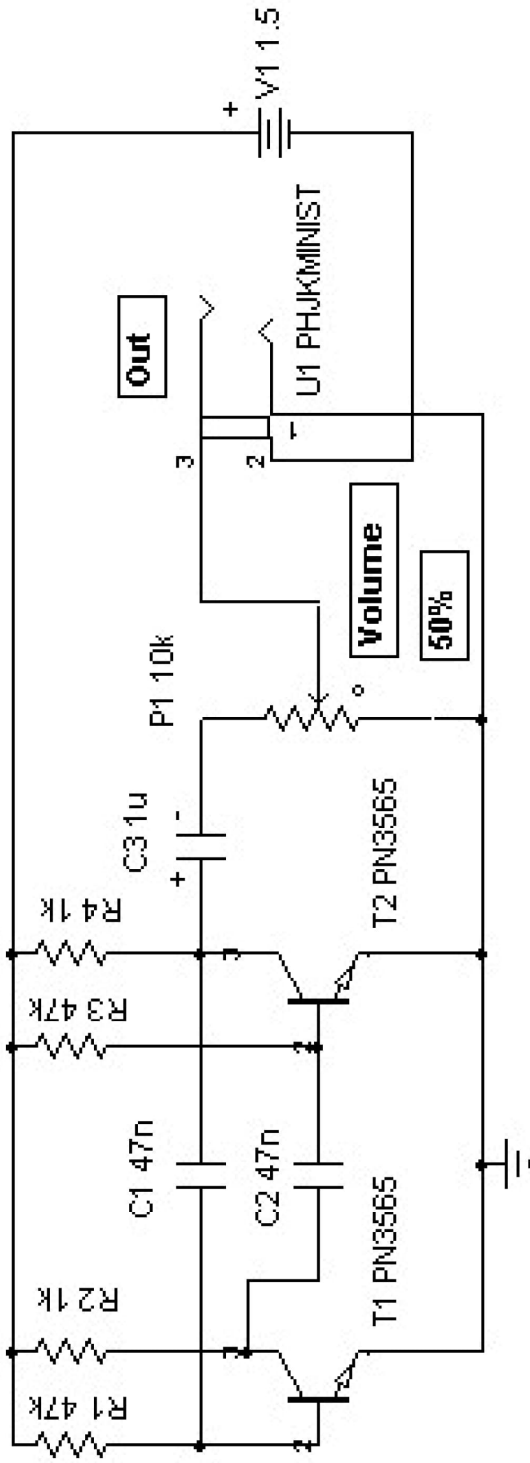

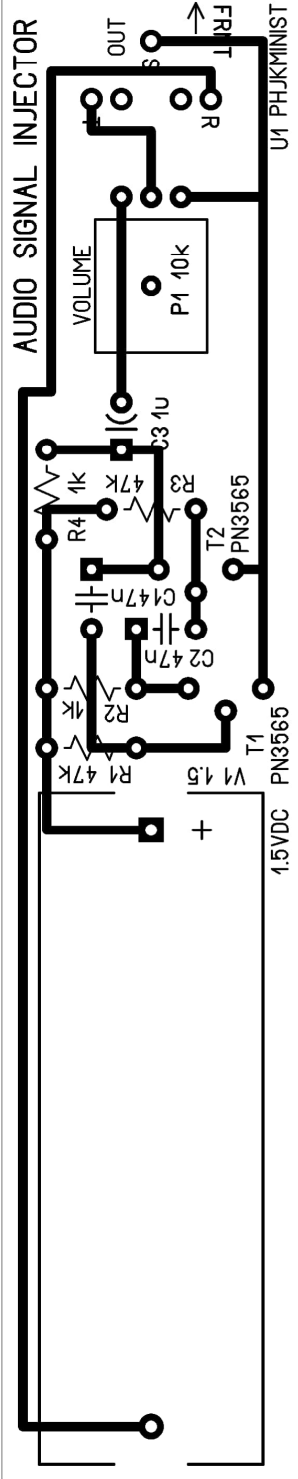

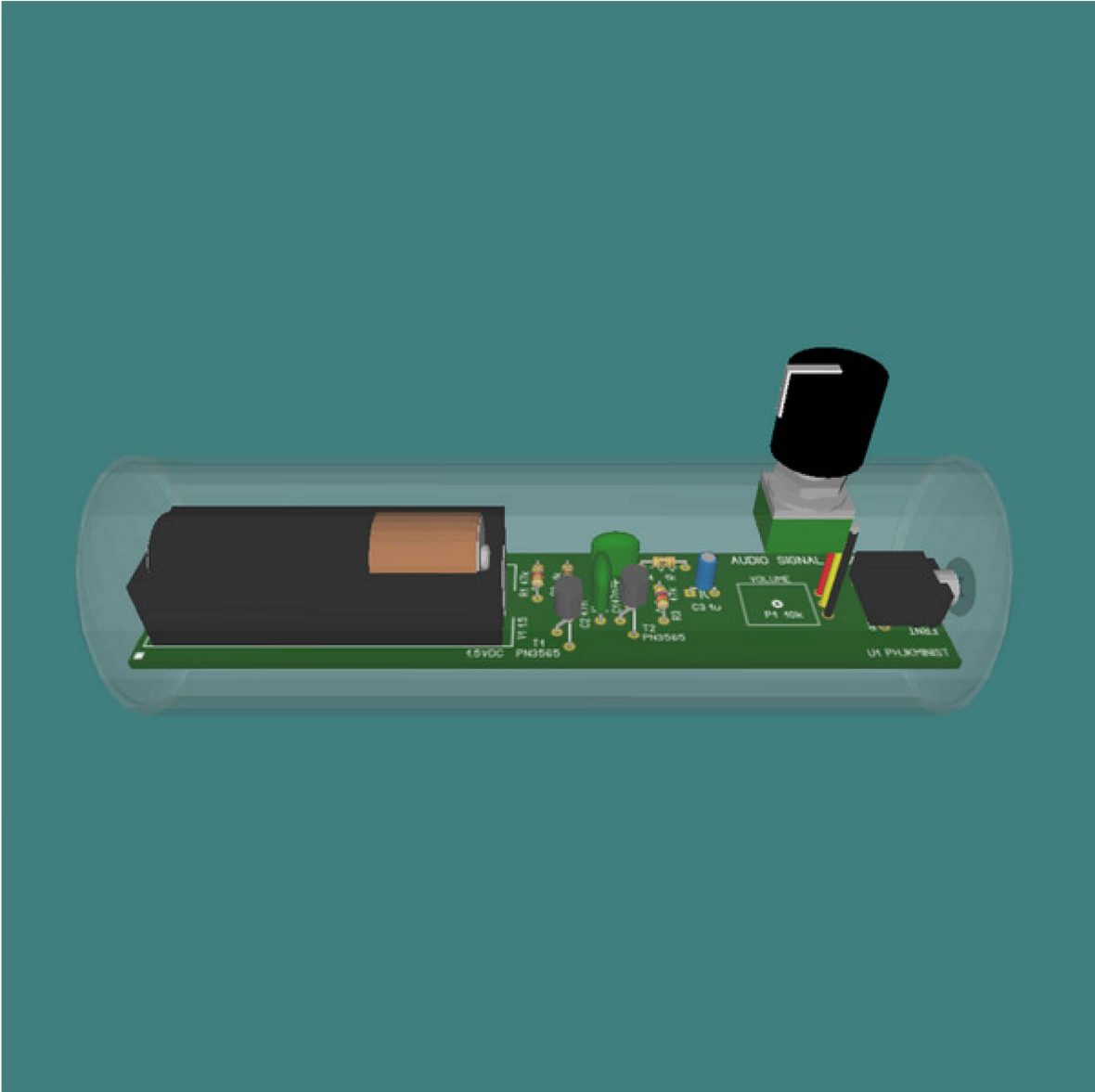

Signal Injector/Tracer

Signal Injector/Tracer Schematic

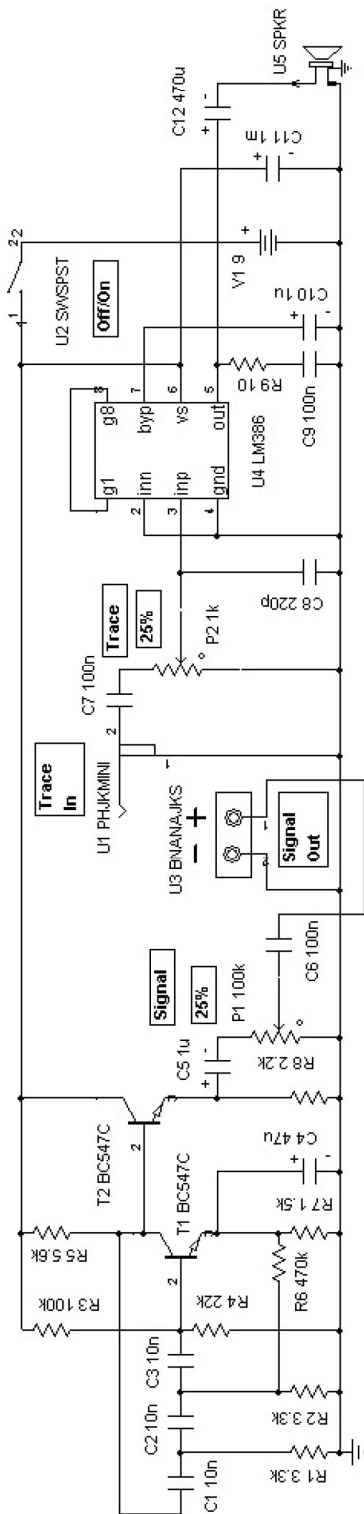

SIGNAL INJECTOR/TRACER

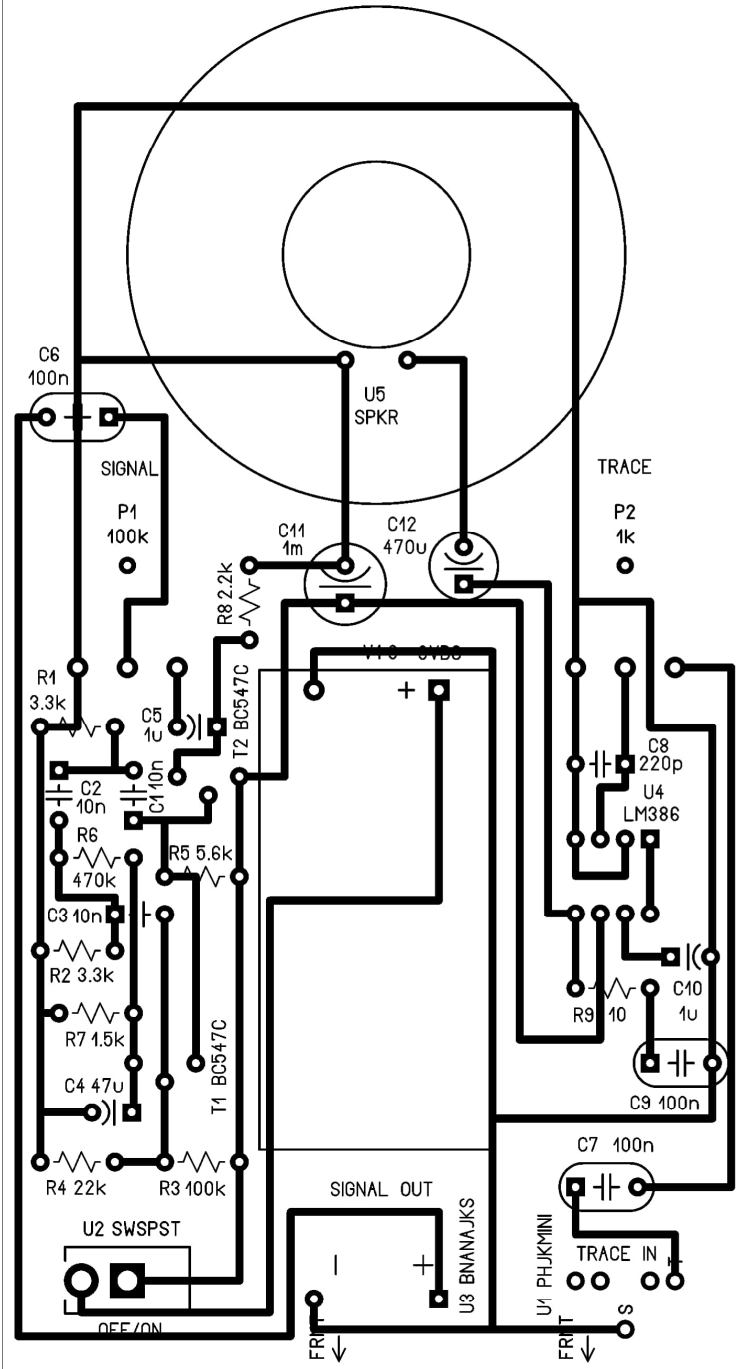

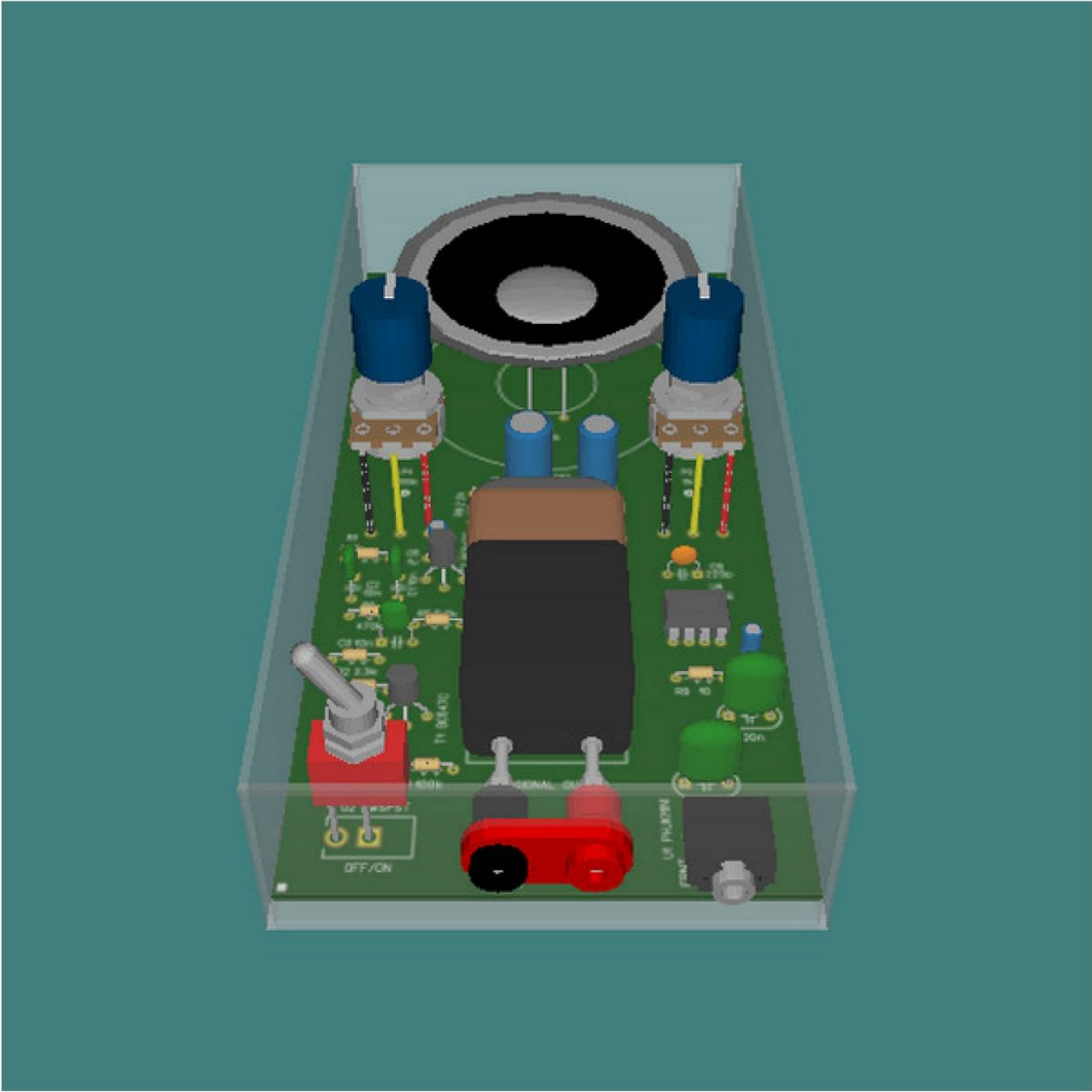

LM386 Low Voltage Audio Amplifier

LM386 Low Voltage Audio Amplifier Schematic

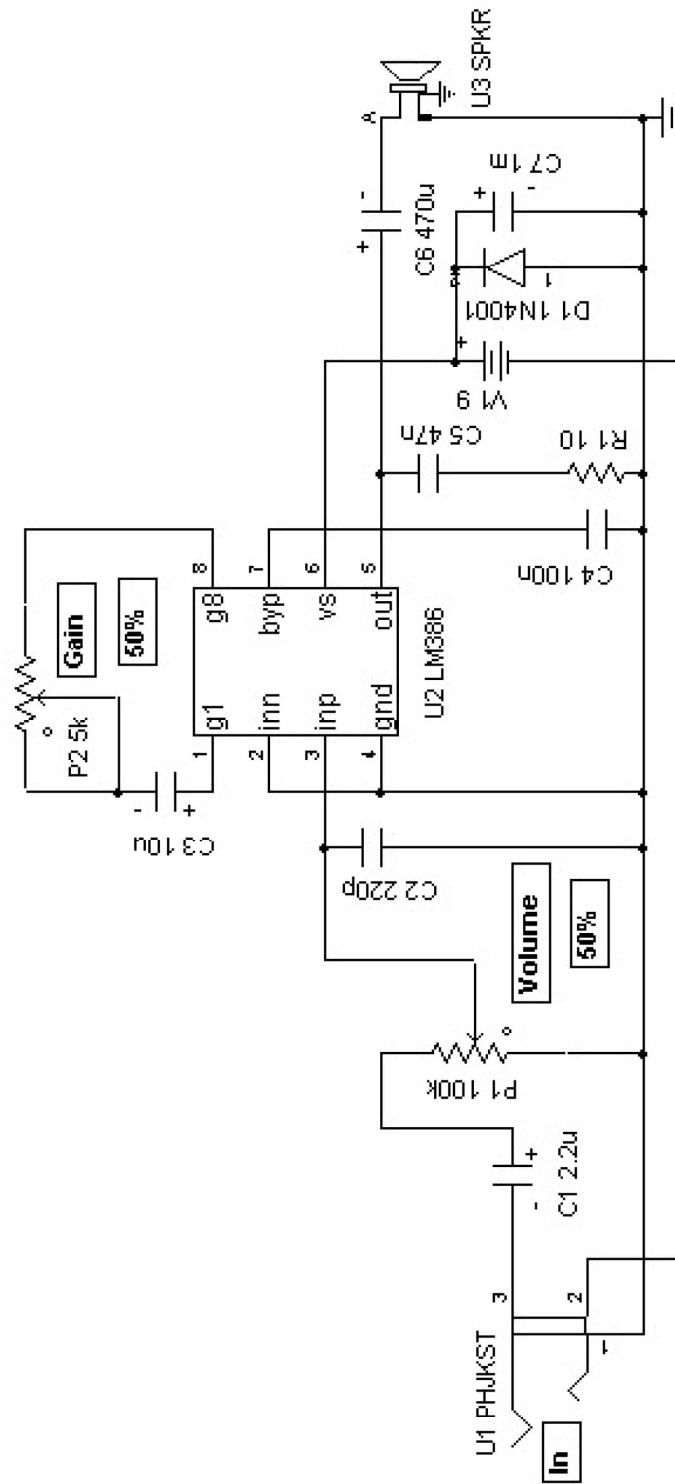

LM386 LOW VOLTAGE AUDIO AMPLIFIER

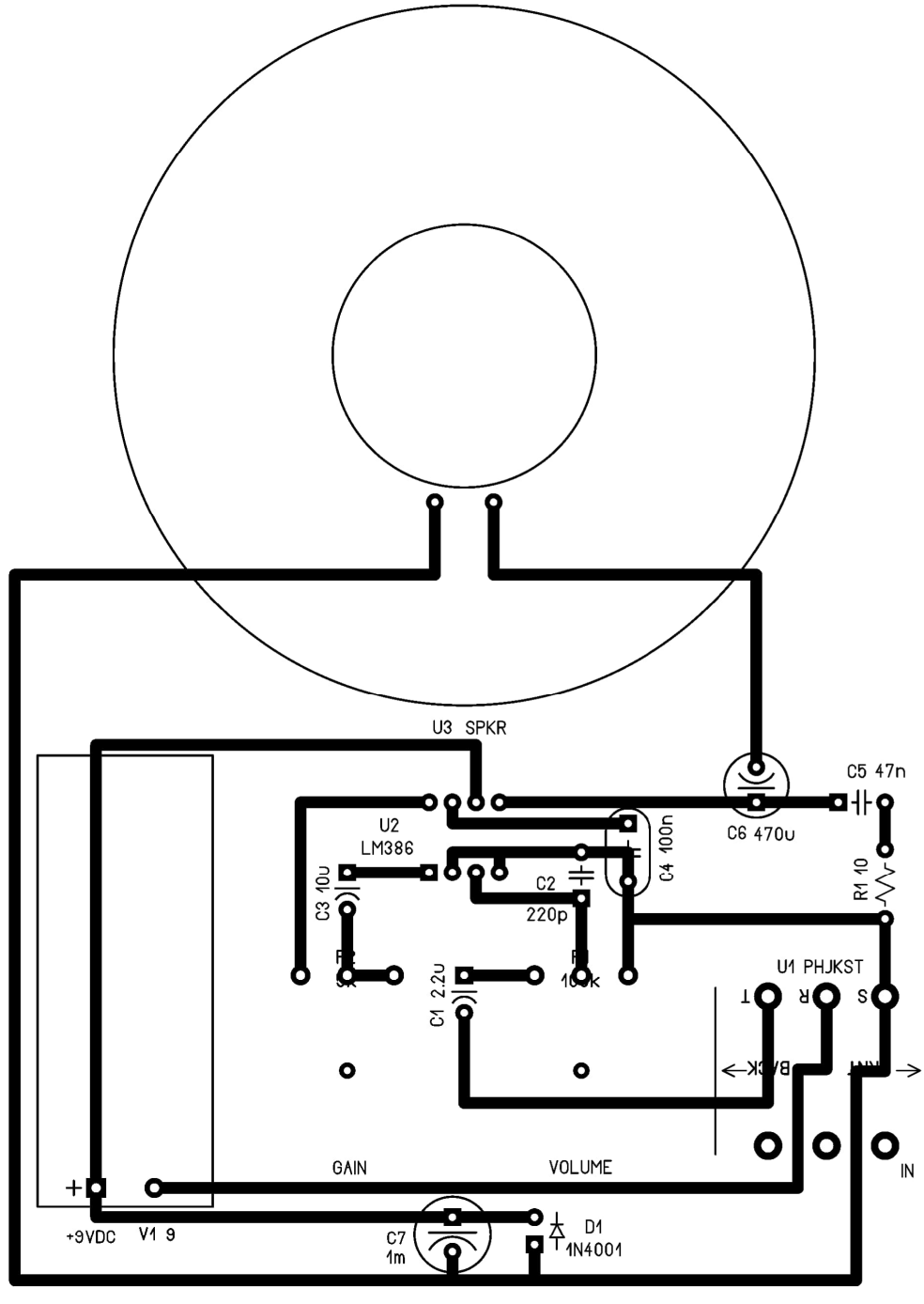

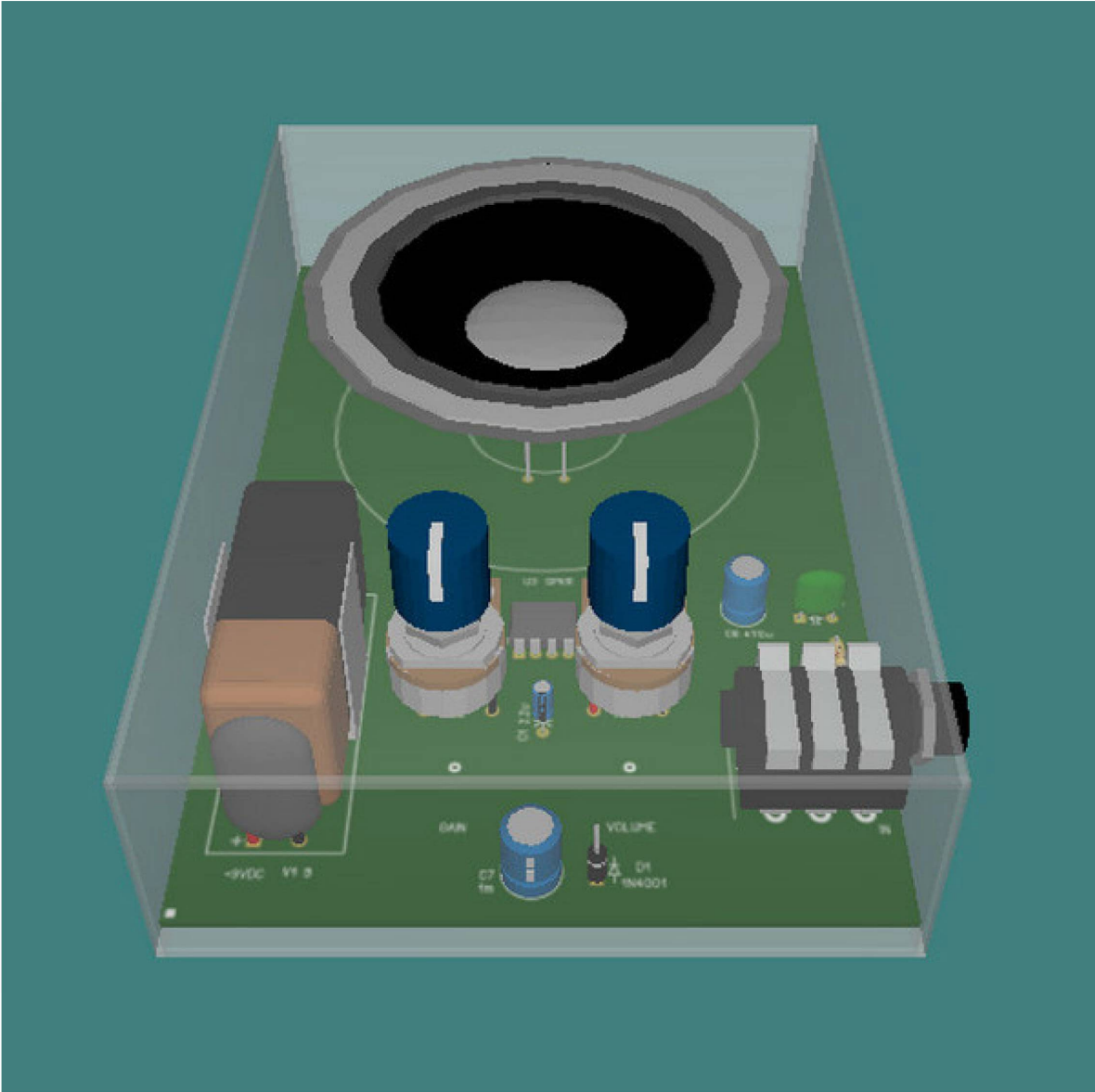

DC Power Supply Projects:

5 VDC w/Backup Power

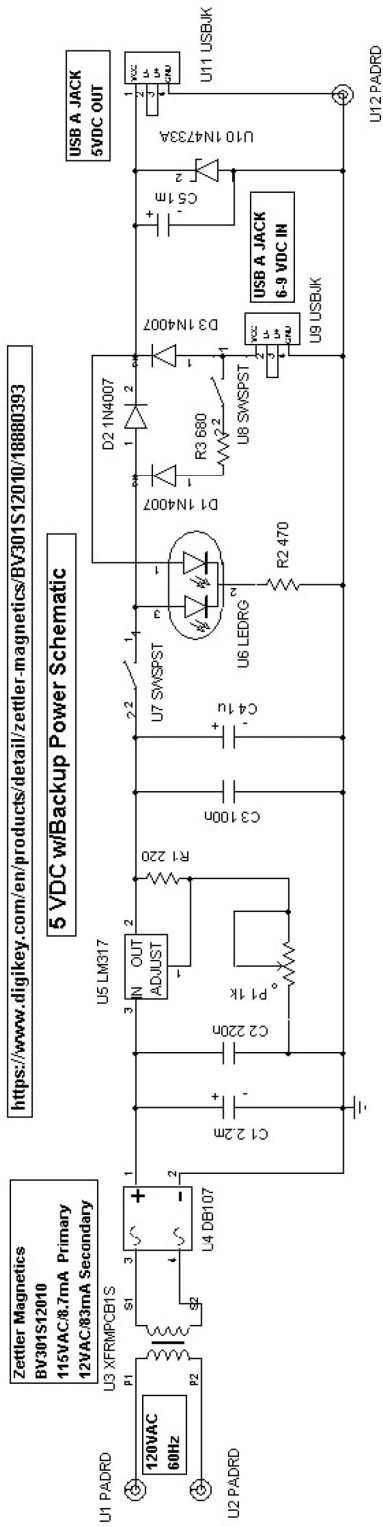

<https://www.digikey.com/en/products/detail/zettler-magnetics/BV301S12010/18880393>

5 VDC w/Backup Power Schematic

Zettler Magnetics
 BV301S12010
 115VAC/8.7mA Primary
 12VAC/83mA Secondary

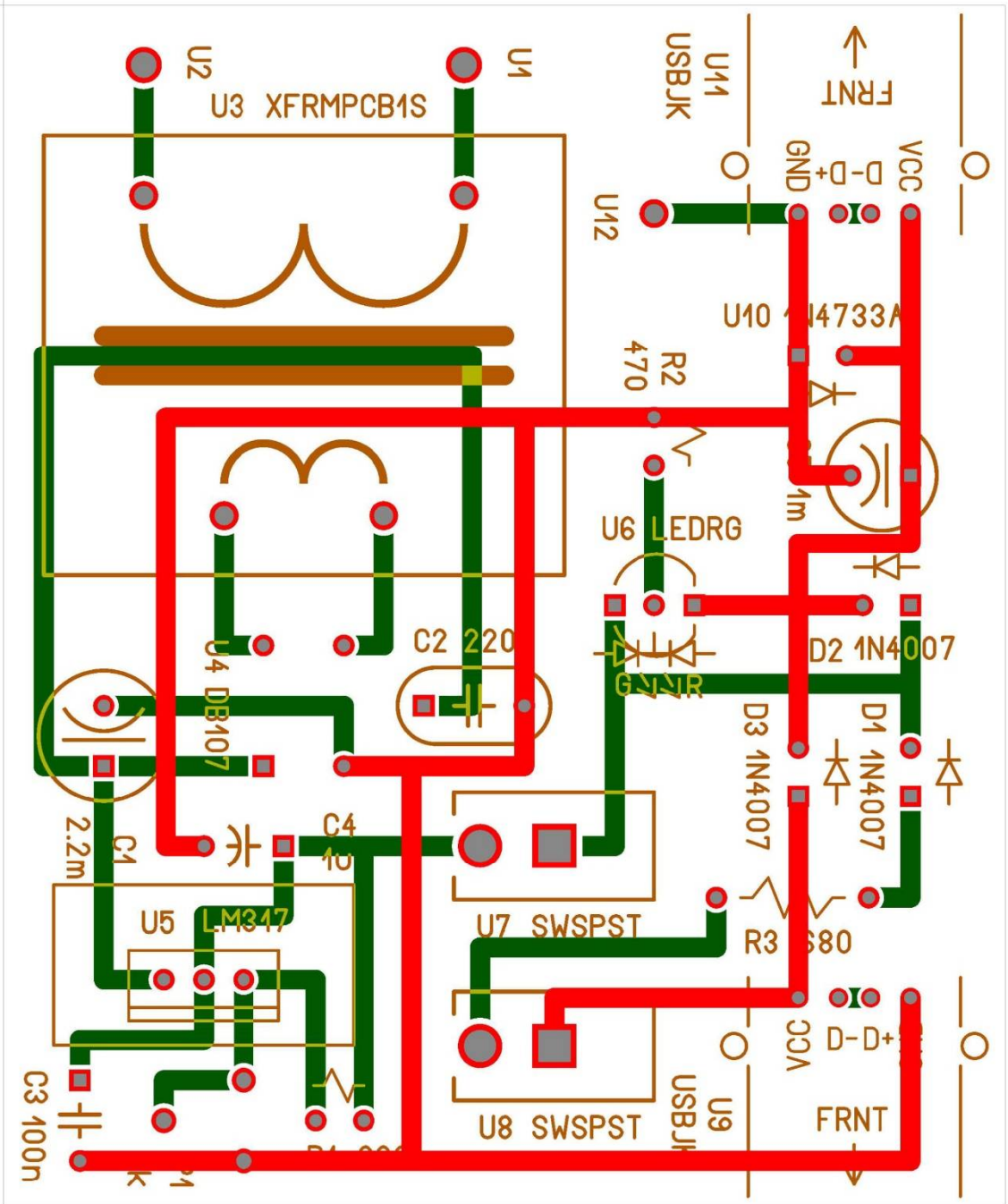

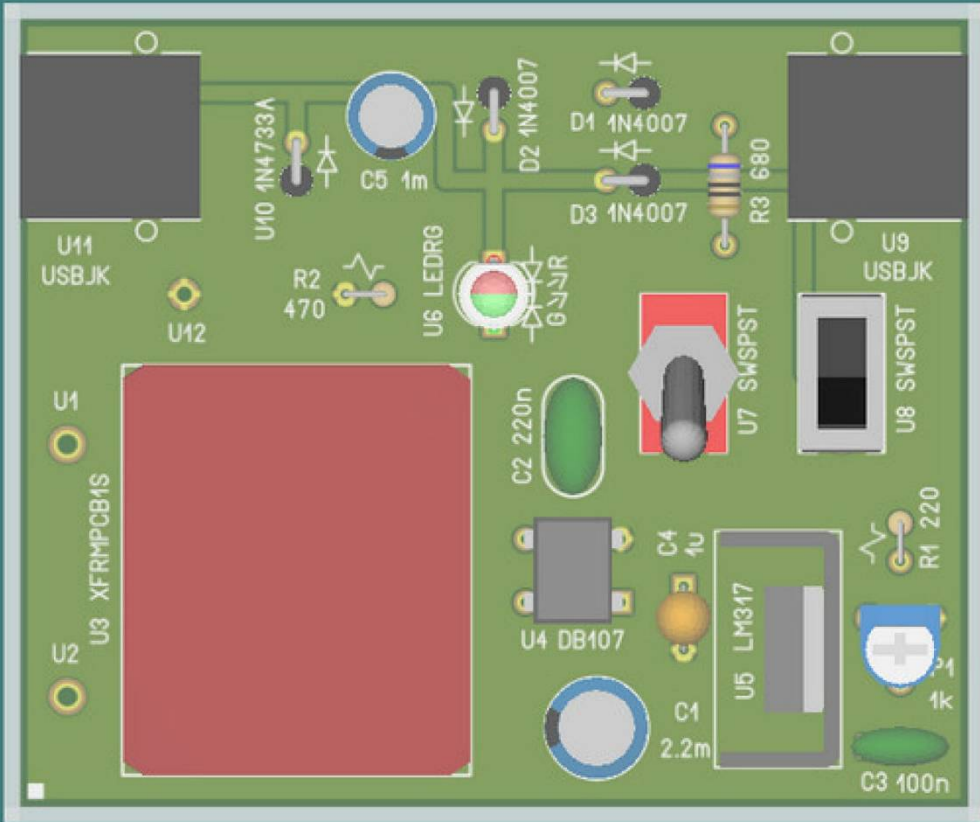

9 VDC Power Supply

<https://www.digikey.com/en/products/detail/zettler-magnetics/BV301S15020/22639657>

Zettler Magnetics
BV301S15020
115VAC/17.3mA Primary
15VAC/133mA Secondary

9 VDC Power Supply Schematic

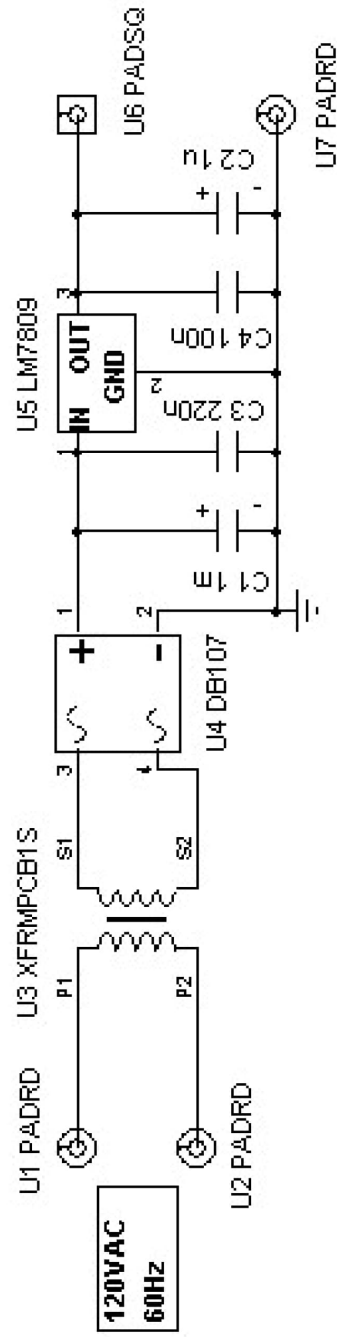

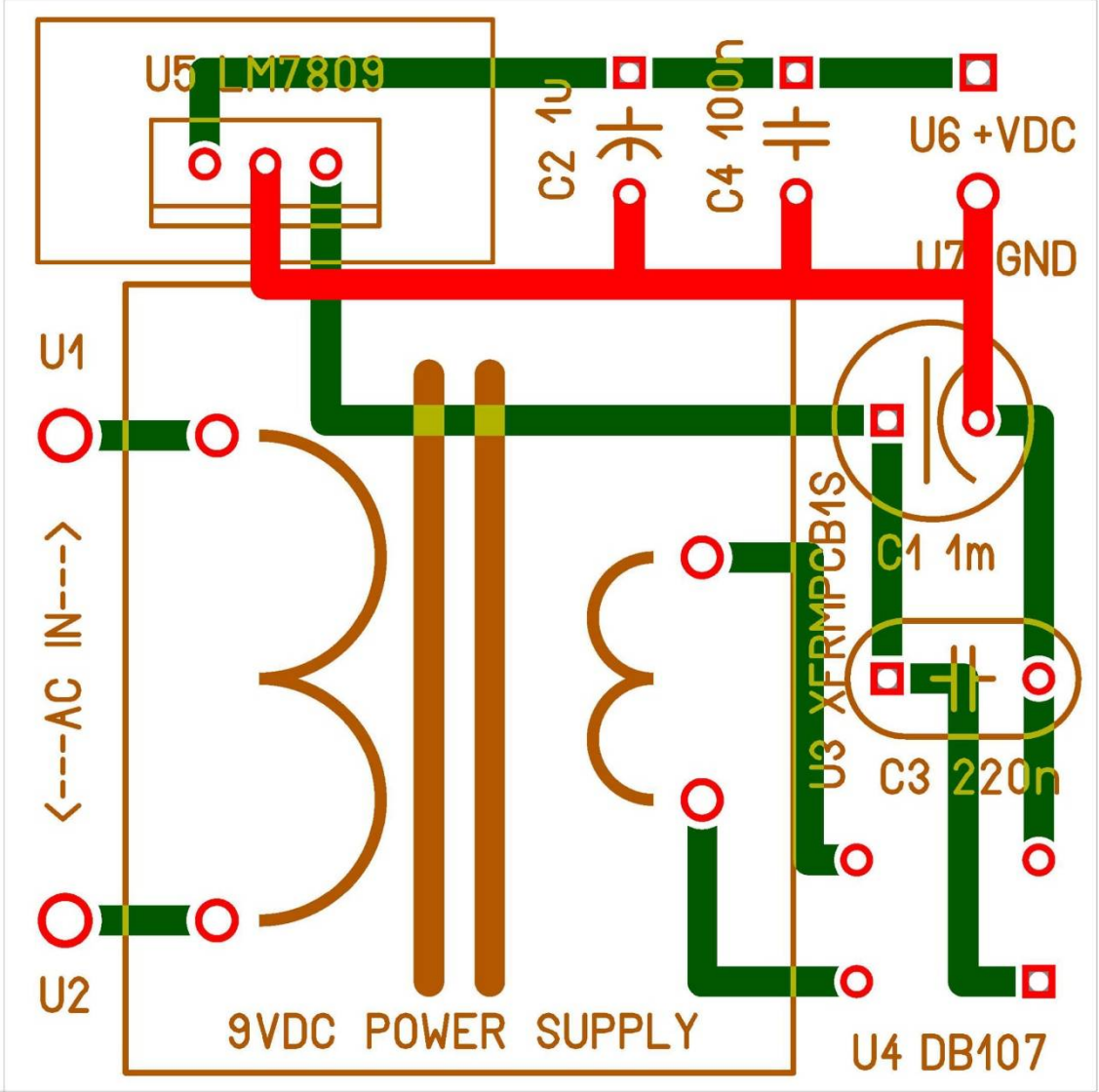

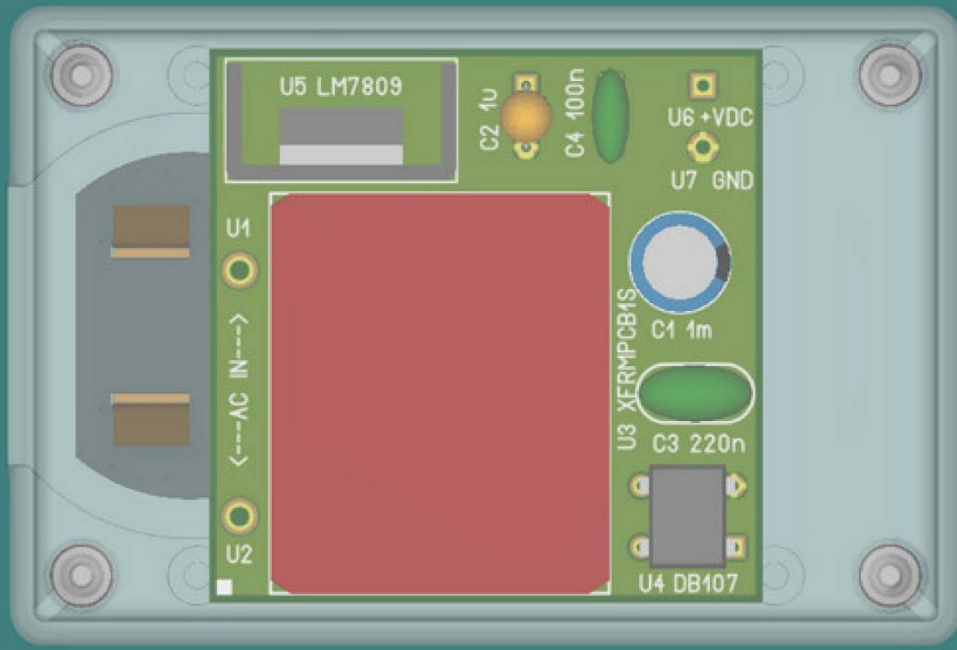

Multi-Voltage Power Supply

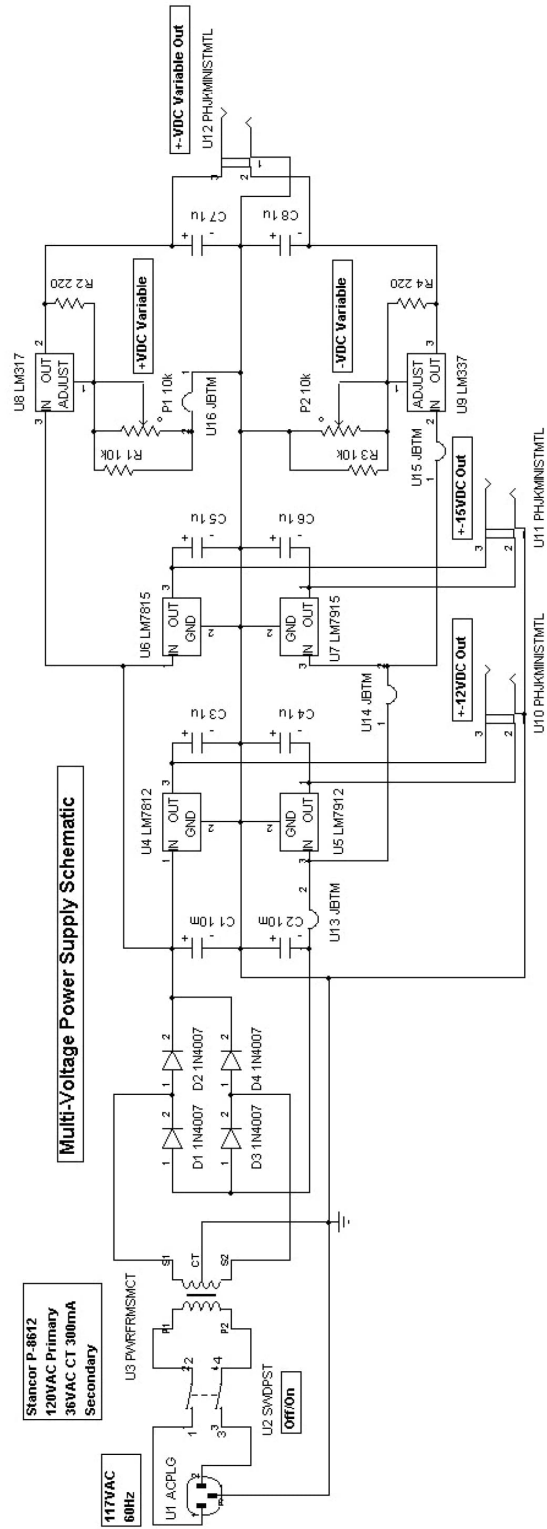

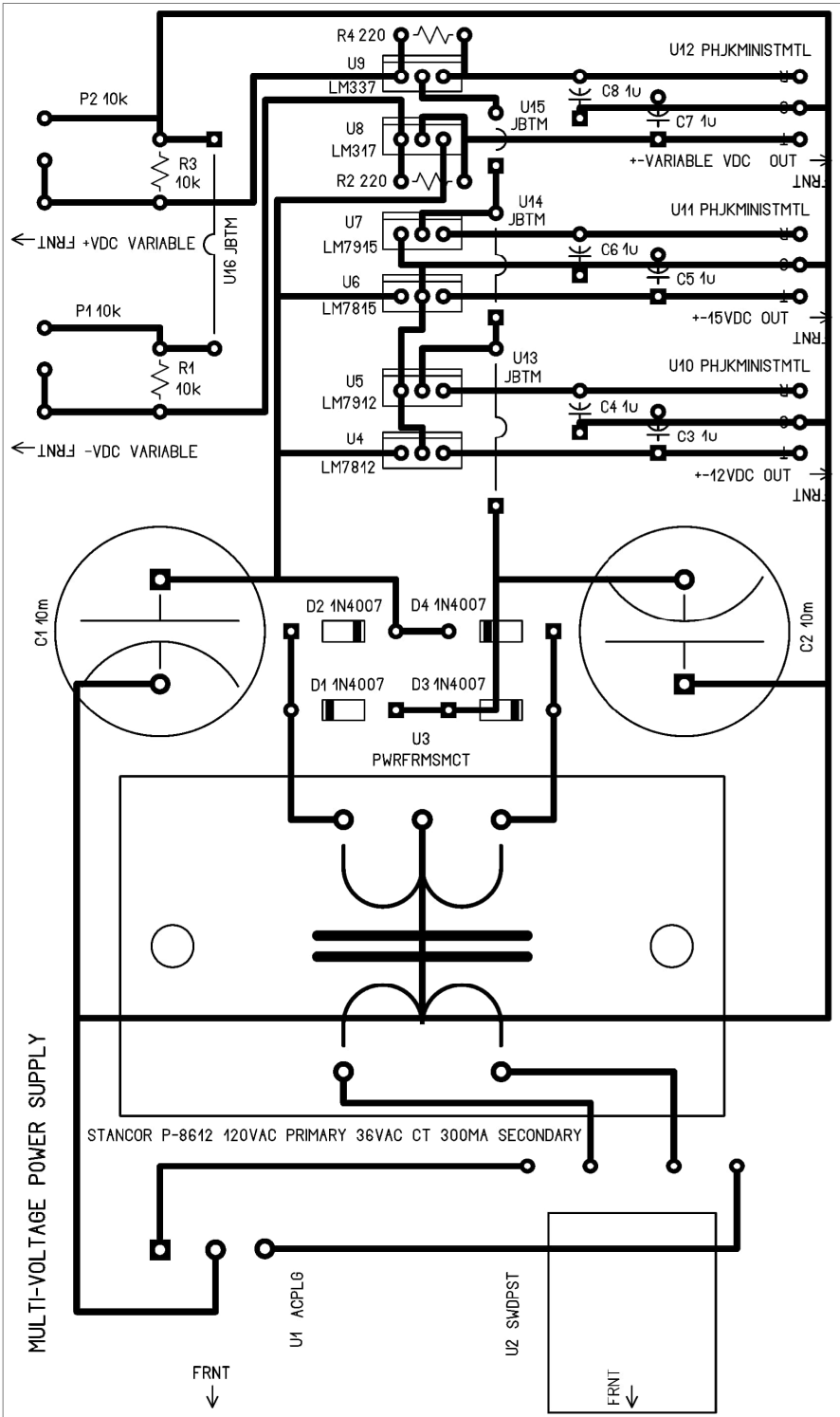

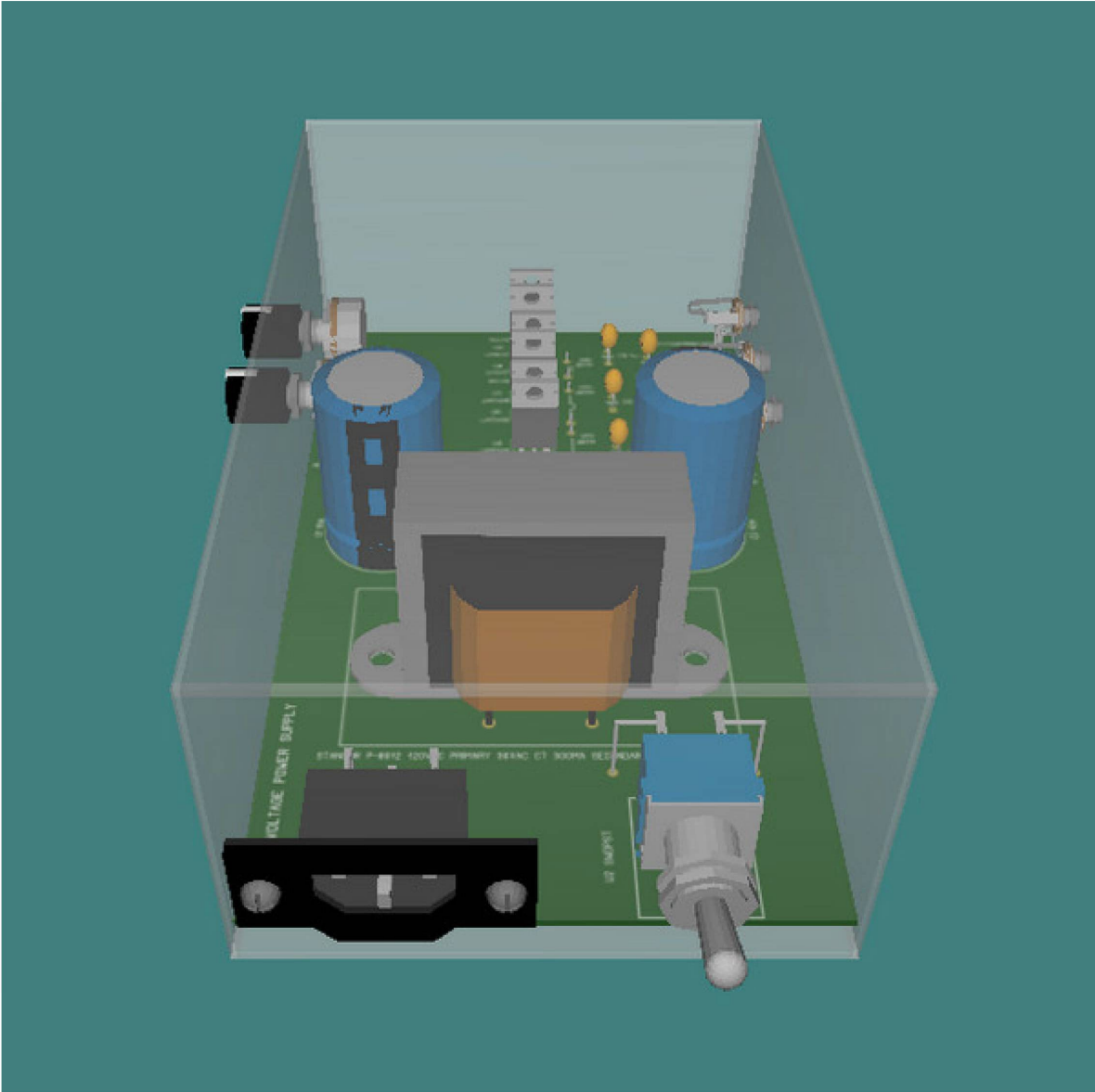

Variable DC Power Supply 1

<https://www.digikey.com/en/products/detail/zettler-magnetics/BV301S24020/22639784>

Zettler Magnetics
 BV301S24020
 115VAC/17.3mA Primary
 24VAC/83mA Secondary

Variable DC Power Supply 1 Schematic

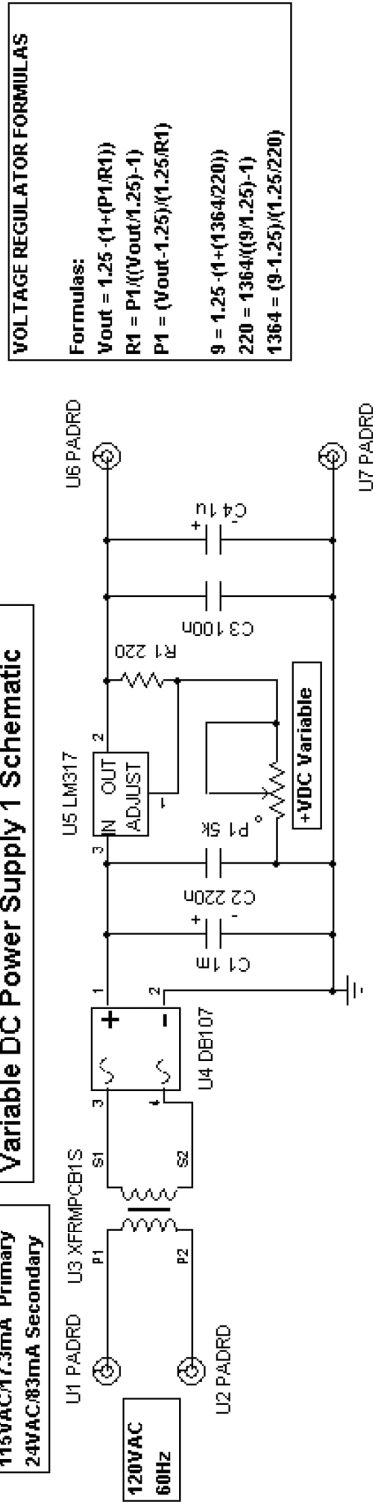

VOLTAGE REGULATOR FORMULAS

Formulas:
 $V_{out} = 1.25 \cdot (1 + (P1/R1))$
 $R1 = P1 / ((V_{out} / 1.25) - 1)$
 $P1 = (V_{out} - 1.25) \cdot (1.25 / R1)$

$9 = 1.25 \cdot (1 + (1364 / 220))$
 $220 = 1364 / ((9 / 1.25) - 1)$
 $1364 = (9 - 1.25) \cdot (1.25 / 220)$

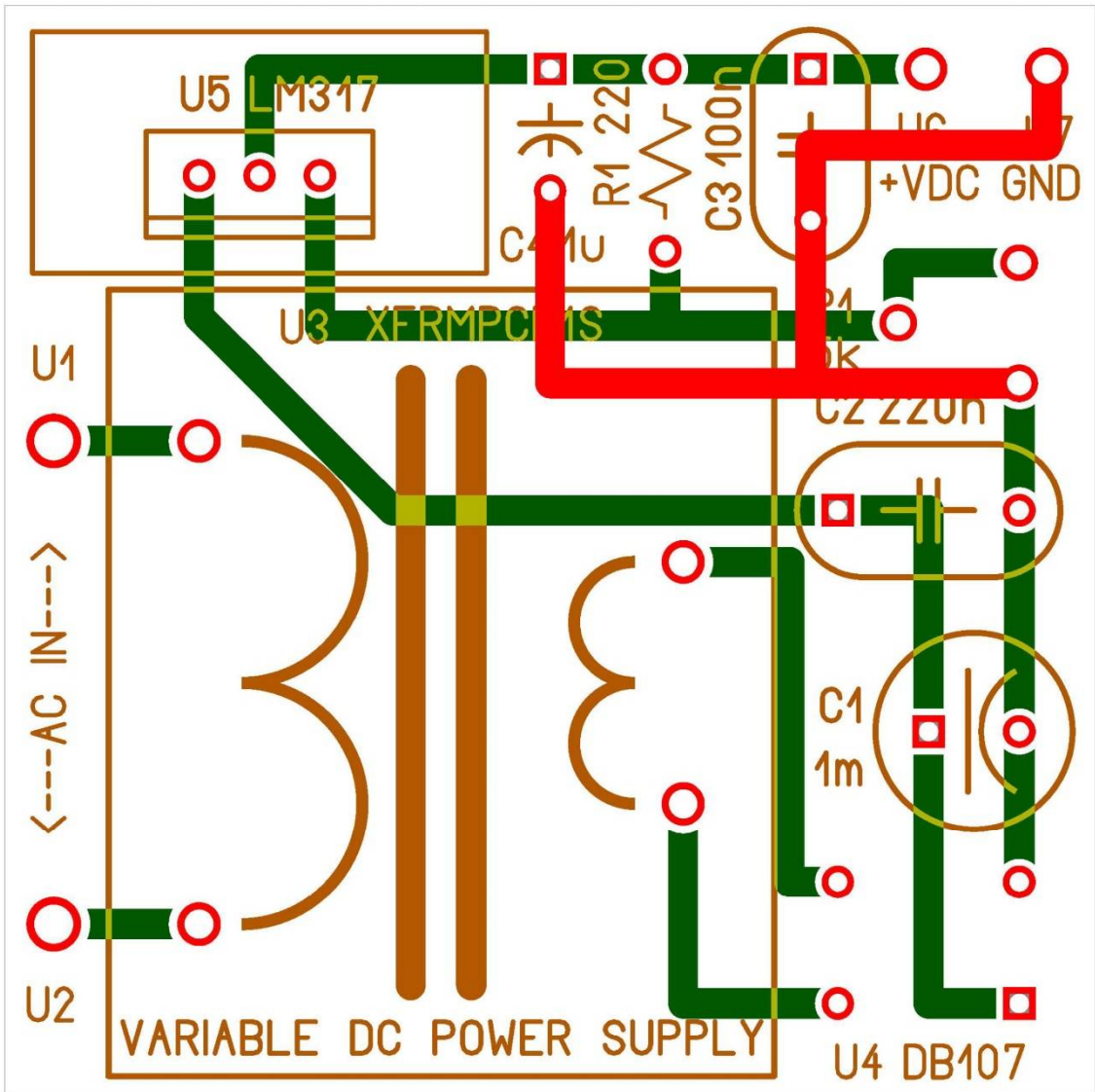

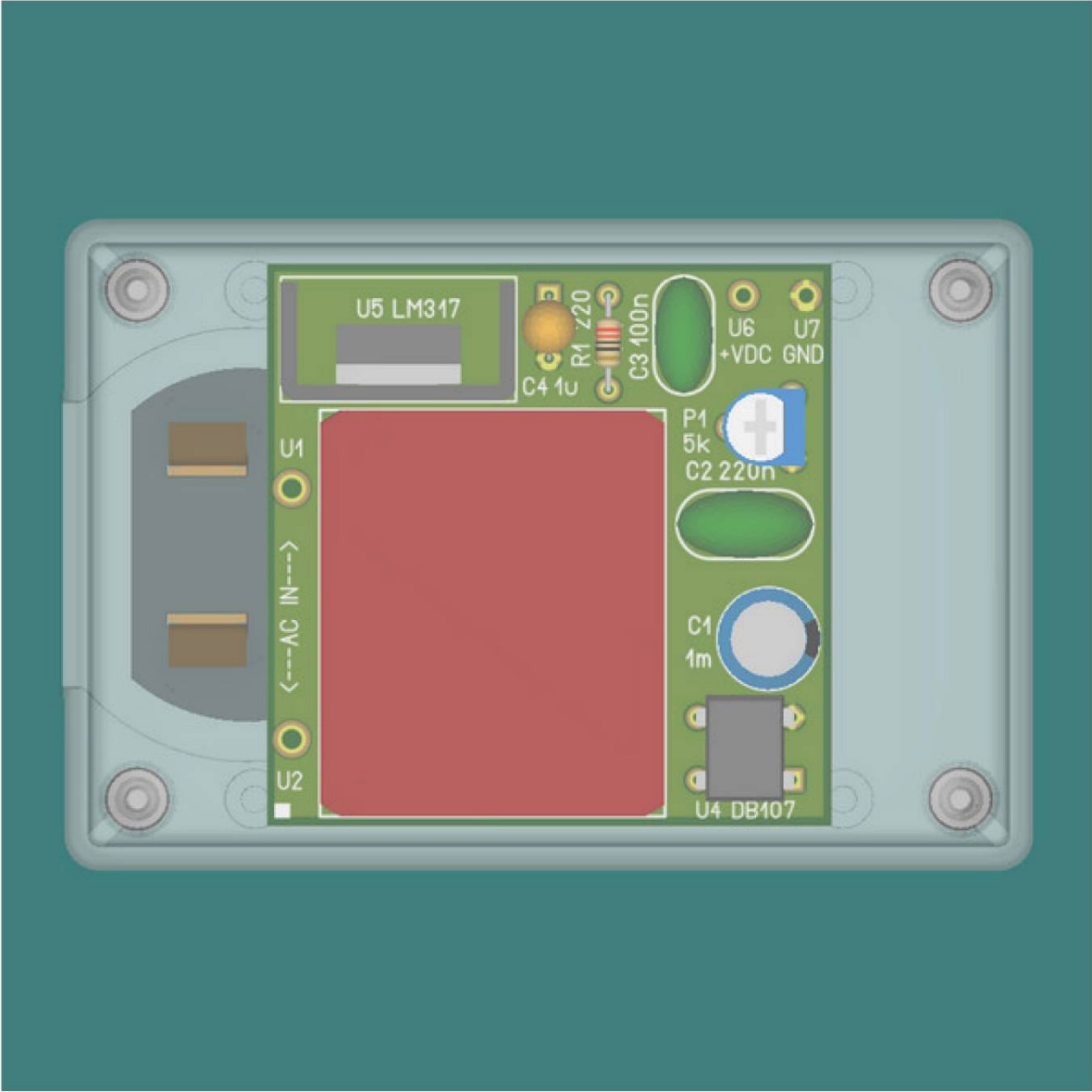

Variable DC Power Supply 2

<https://www.digikey.com/en/products/detail/zettler-magnetics/BV301S24020/22639784>

Zettler Magnetics
BV301S24020
115VAC/17.3mA Primary
24VAC/83mA Secondary

Variable DC Power Supply 2 Schematic

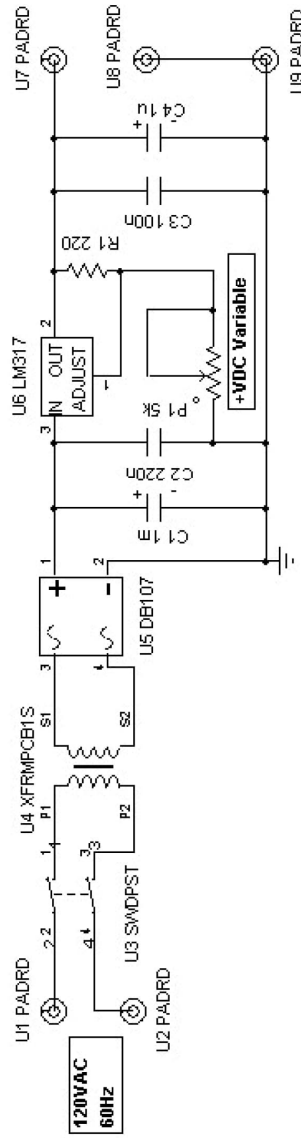

VOLTAGE REGULATOR FORMULAS

Formulas:
 $V_{out} = 1.25 \cdot (1 + (P1/R1))$
 $R1 = P1 / ((V_{out} / 1.25) - 1)$
 $P1 = (V_{out} - 1.25) \cdot (1.25 / R1)$
 $9 = 1.25 \cdot (1 + (1364 / 220))$
 $220 = 1364 / ((9 / 1.25) - 1)$
 $1364 = (9 - 1.25) \cdot (1.25 / 220)$

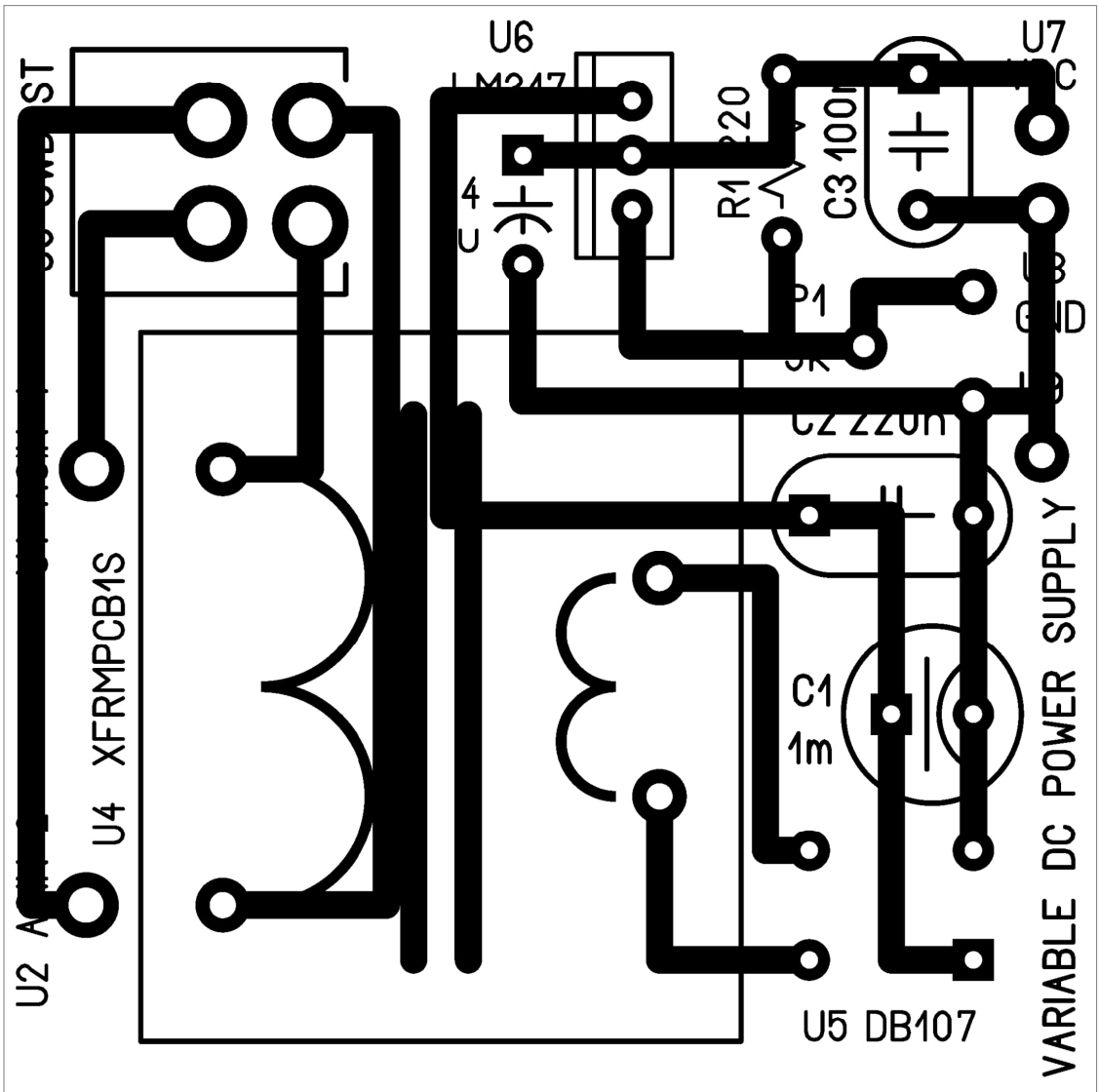

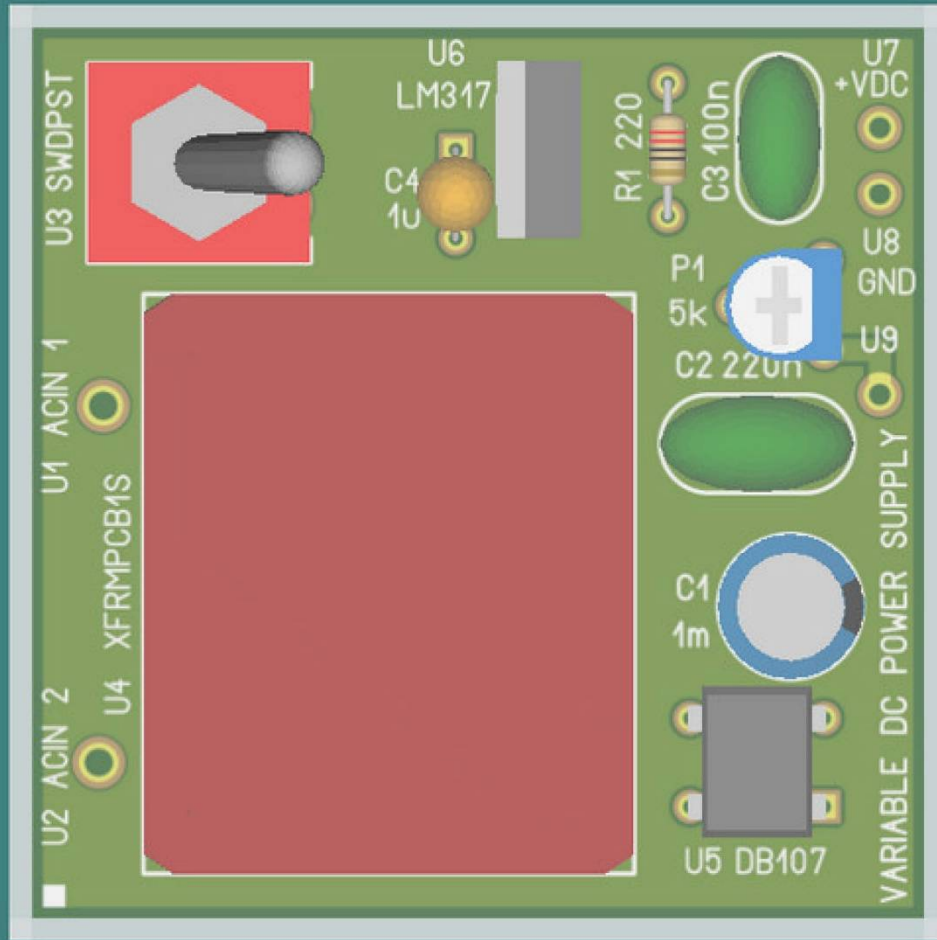

Valve Projects:

Tube/Valve Power Supply

Tube/Valve Power Supply Schematic

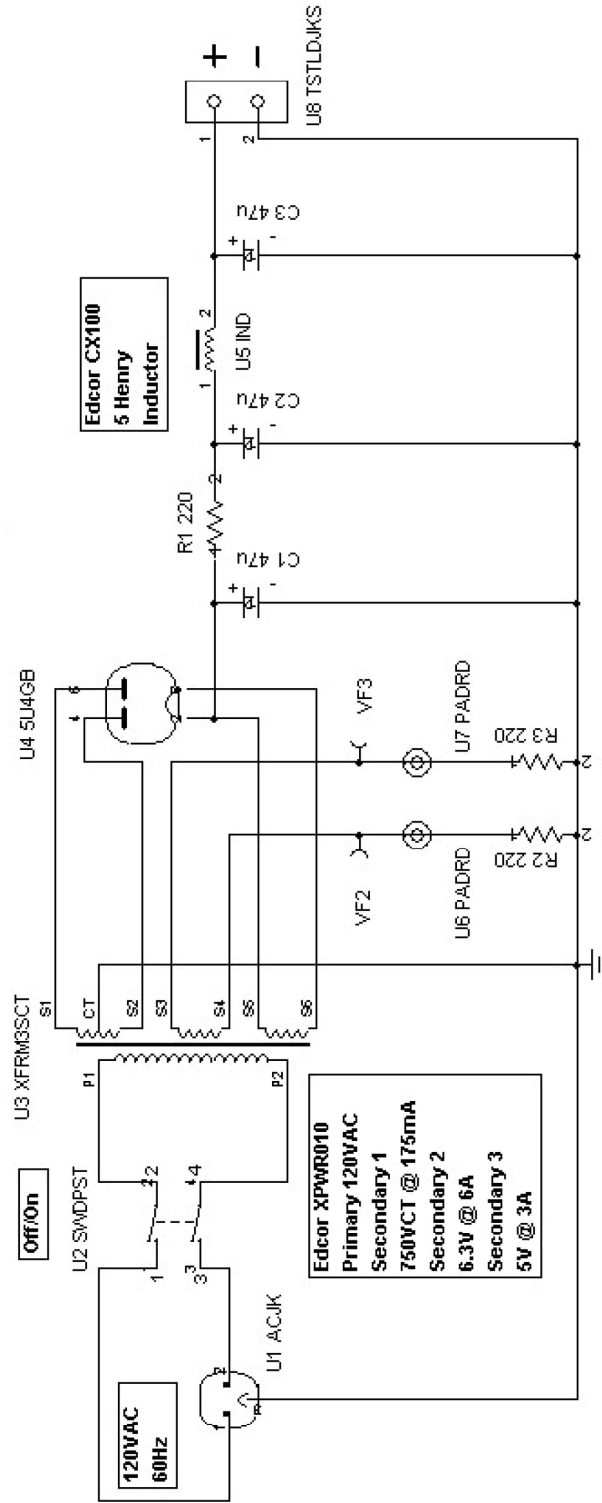

Tube Audio Amplifier 1

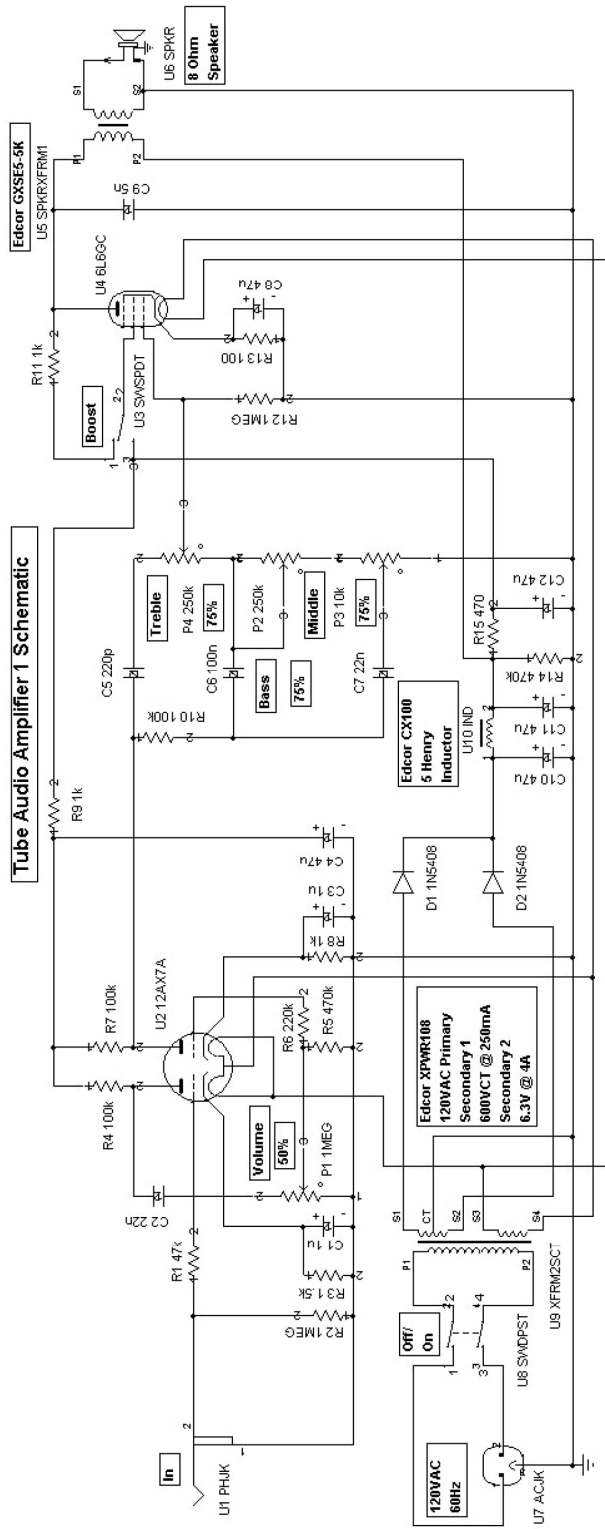

Tube Audio Amplifier 2

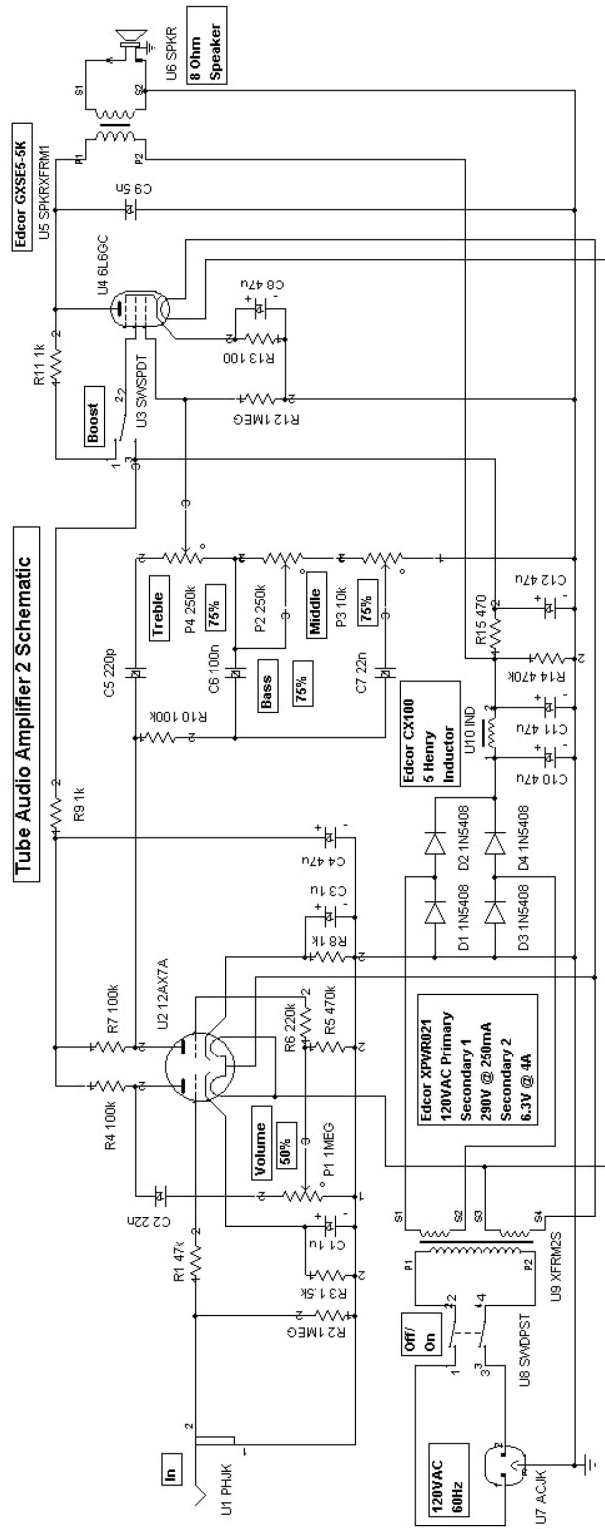

Tube Audio Amplifier 3

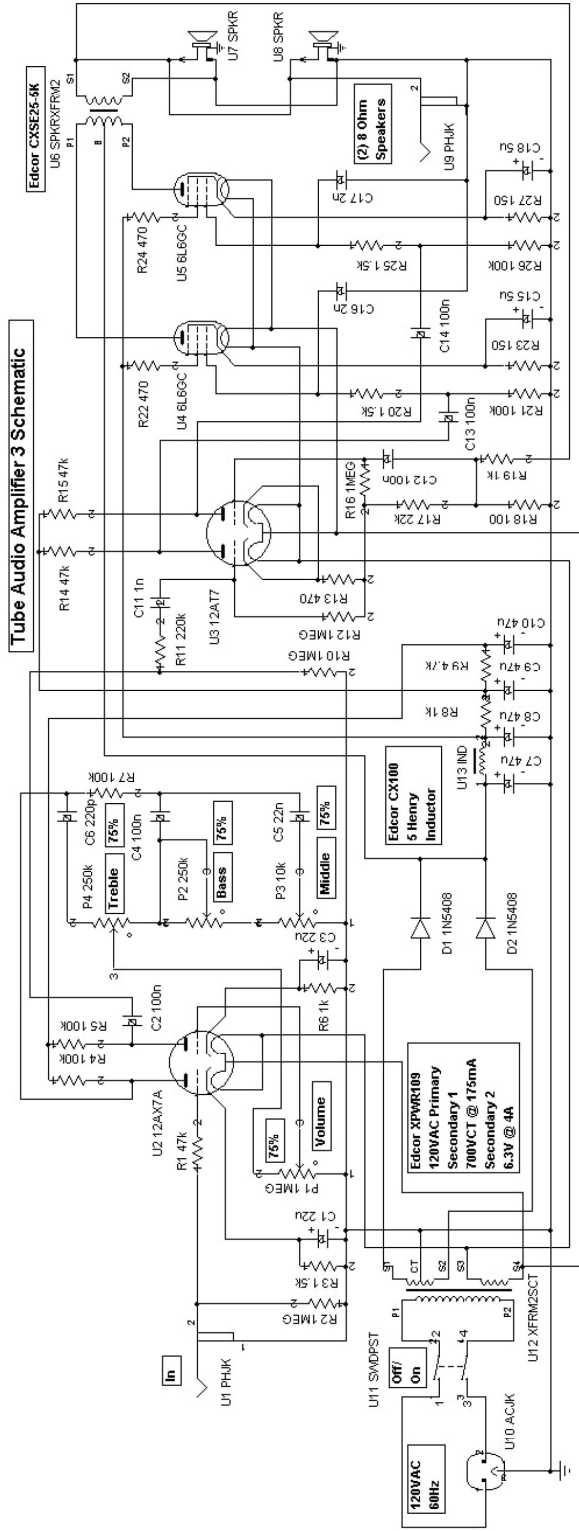

Tube Audio Amplifier 4

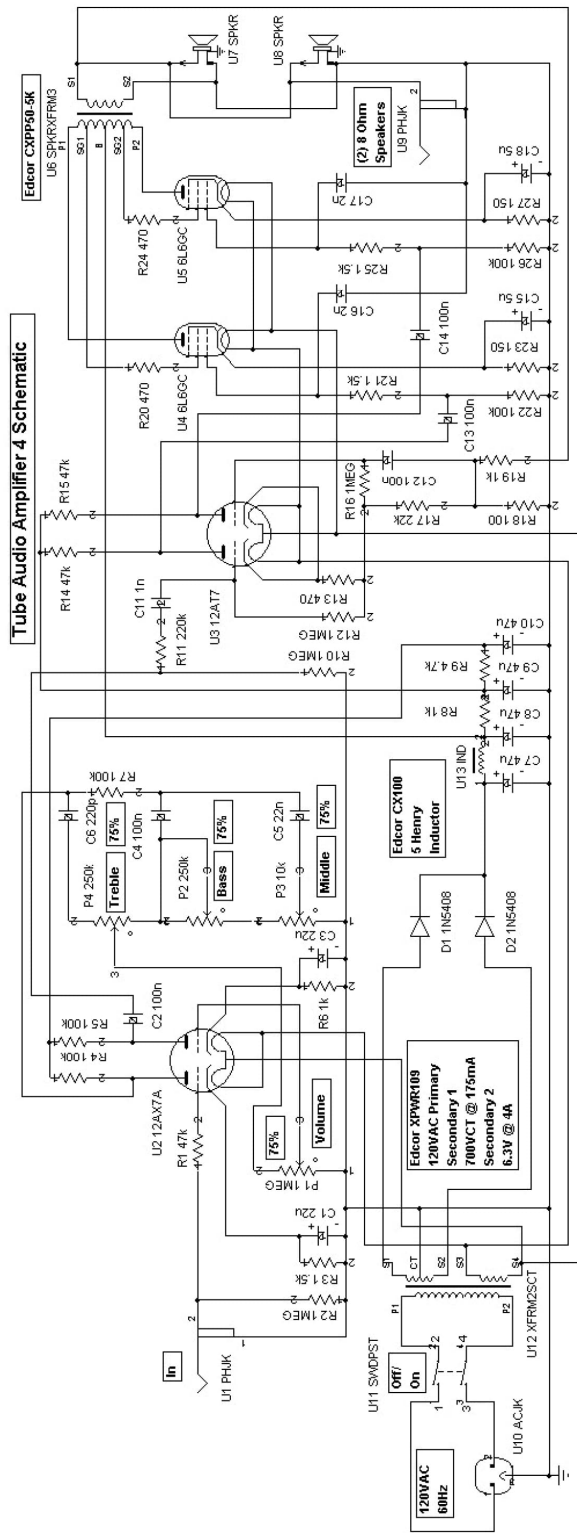

Tube Audio Amplifier 5

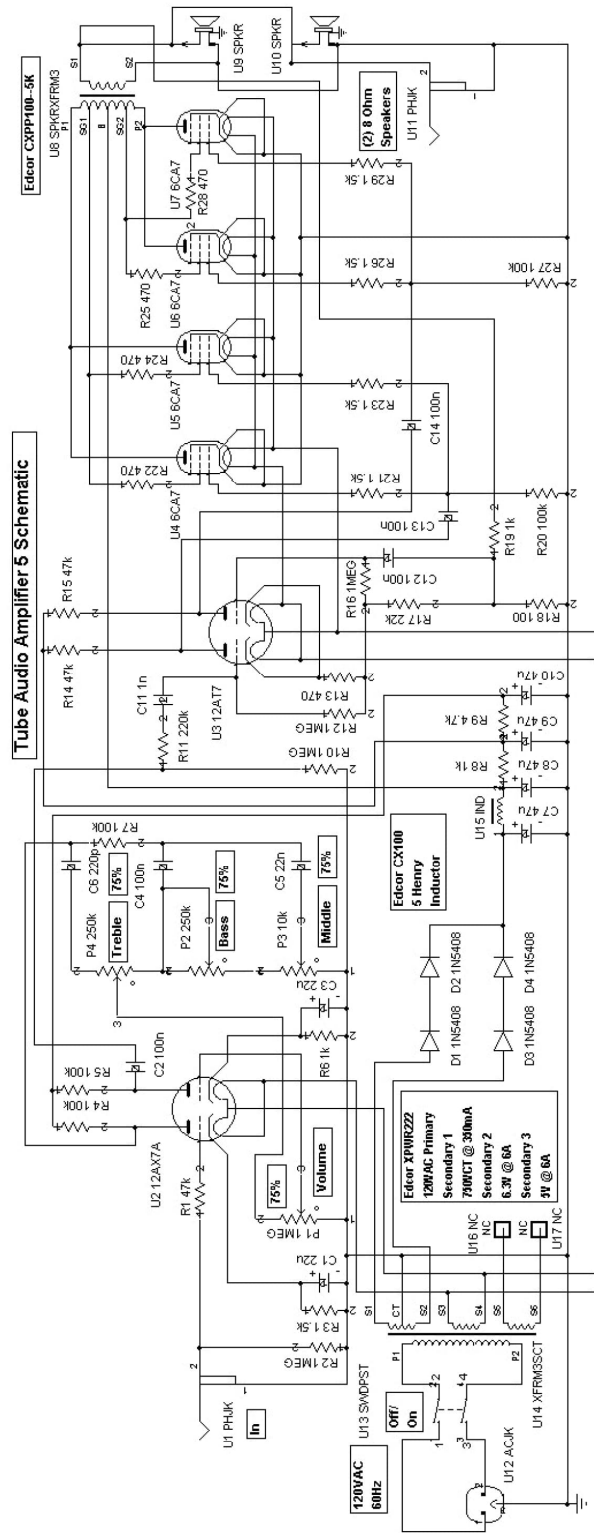

Tube Audio Amplifier 6

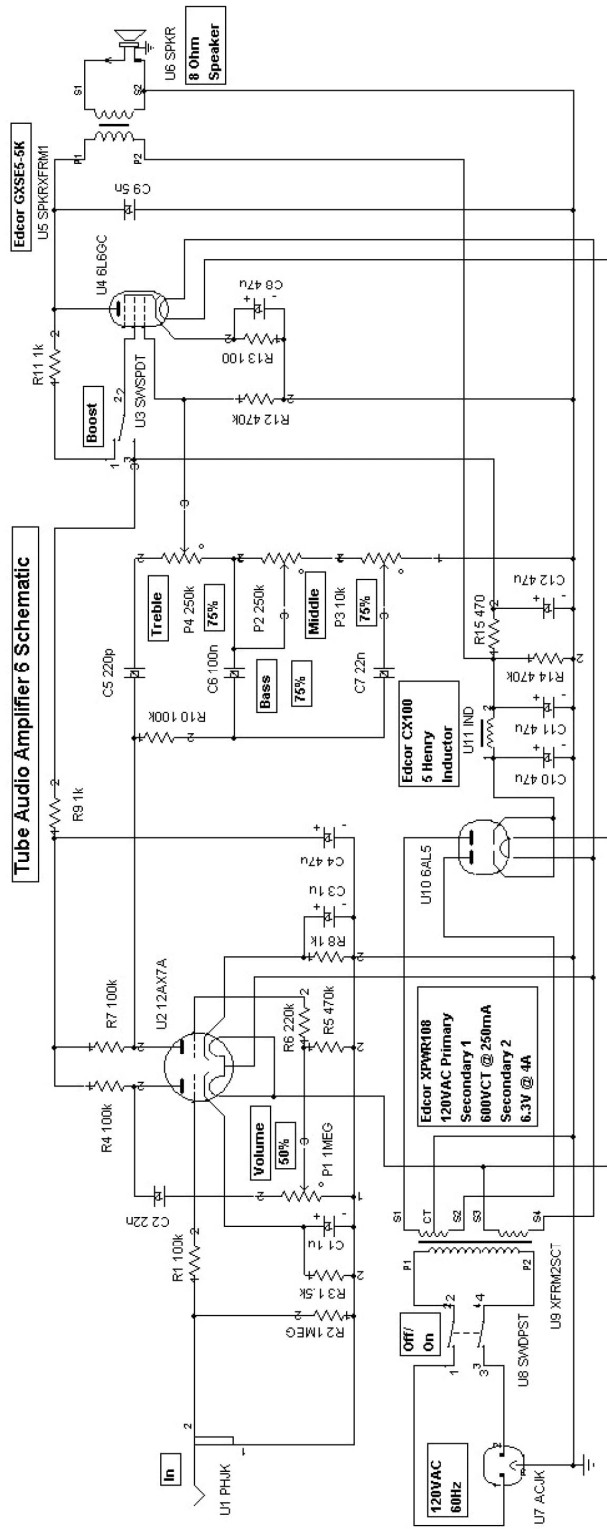

Tube Audio Amplifier 7

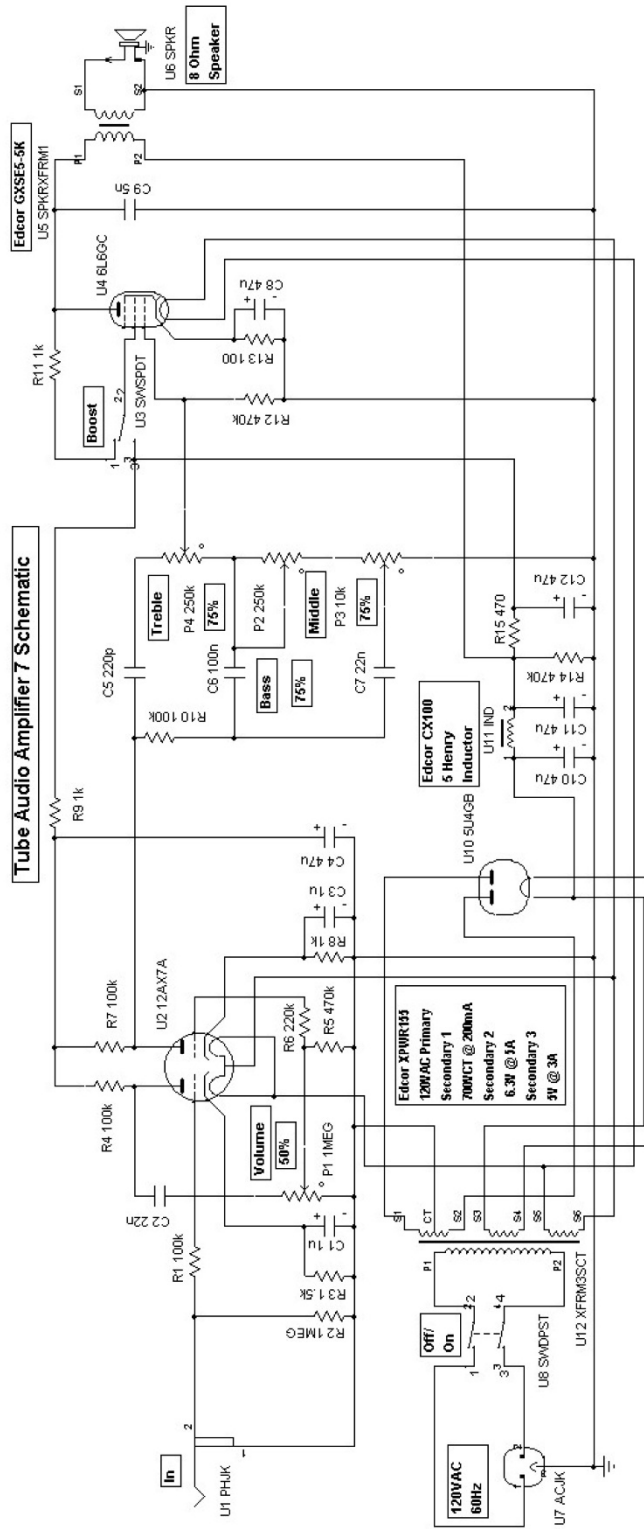

Tube Audio Amplifier 8

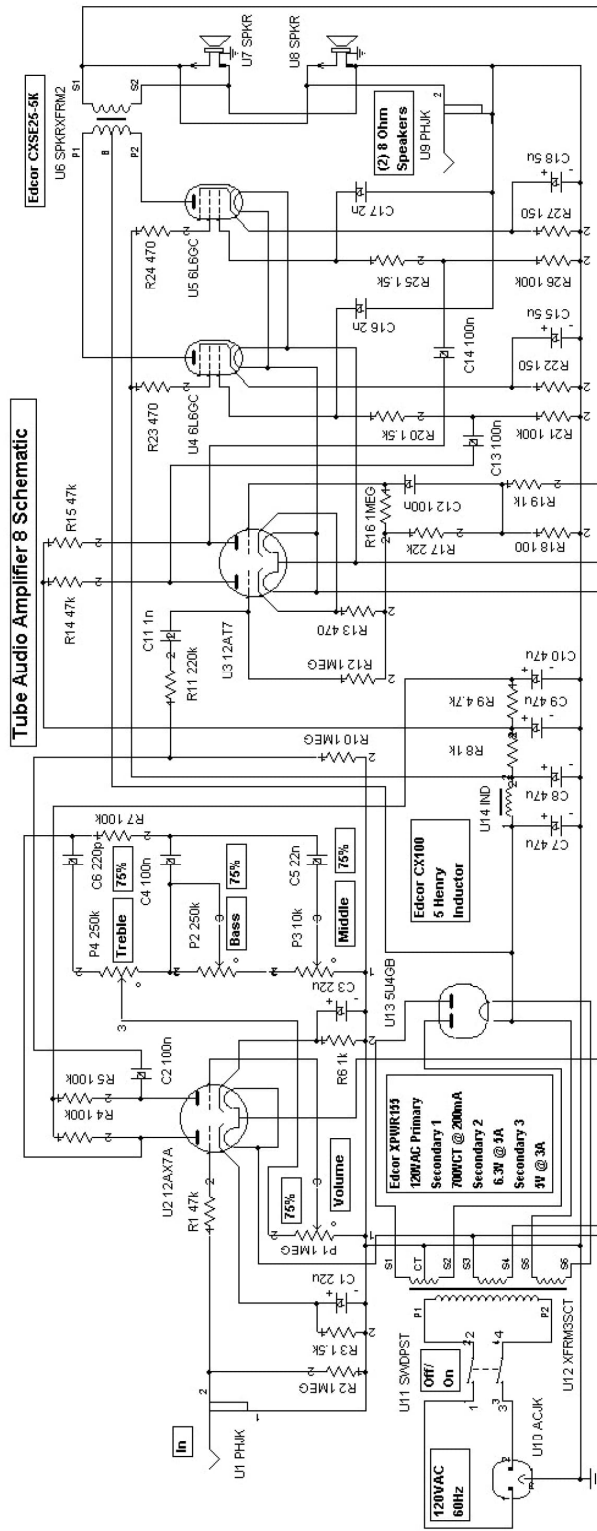

Experimental Projects:

ADSR Effect

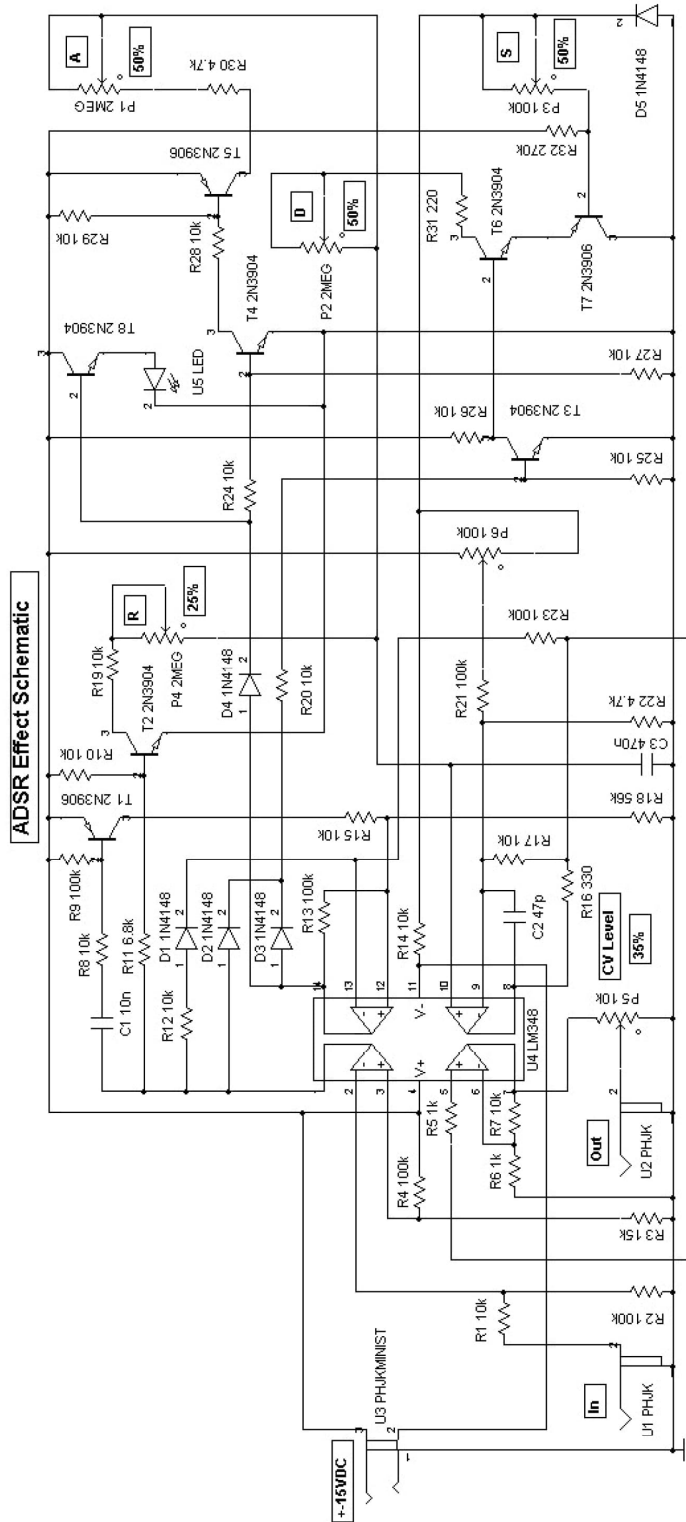

CA3080 Voltage Controlled Amplifier

CA3080 Voltage Controlled Amplifier Schematic

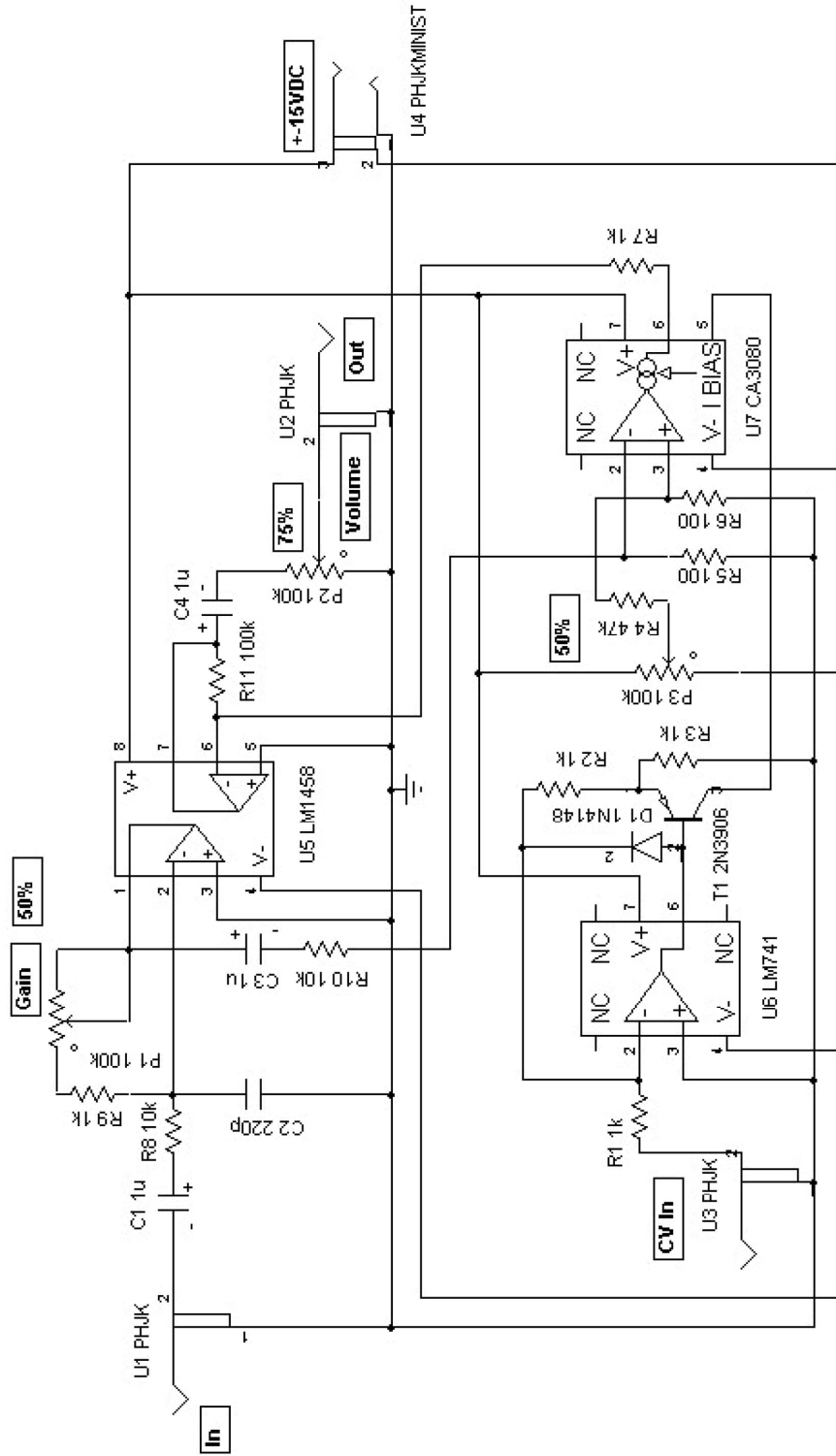

Envelope Follower 1

Envelope Follower 1 Schematic

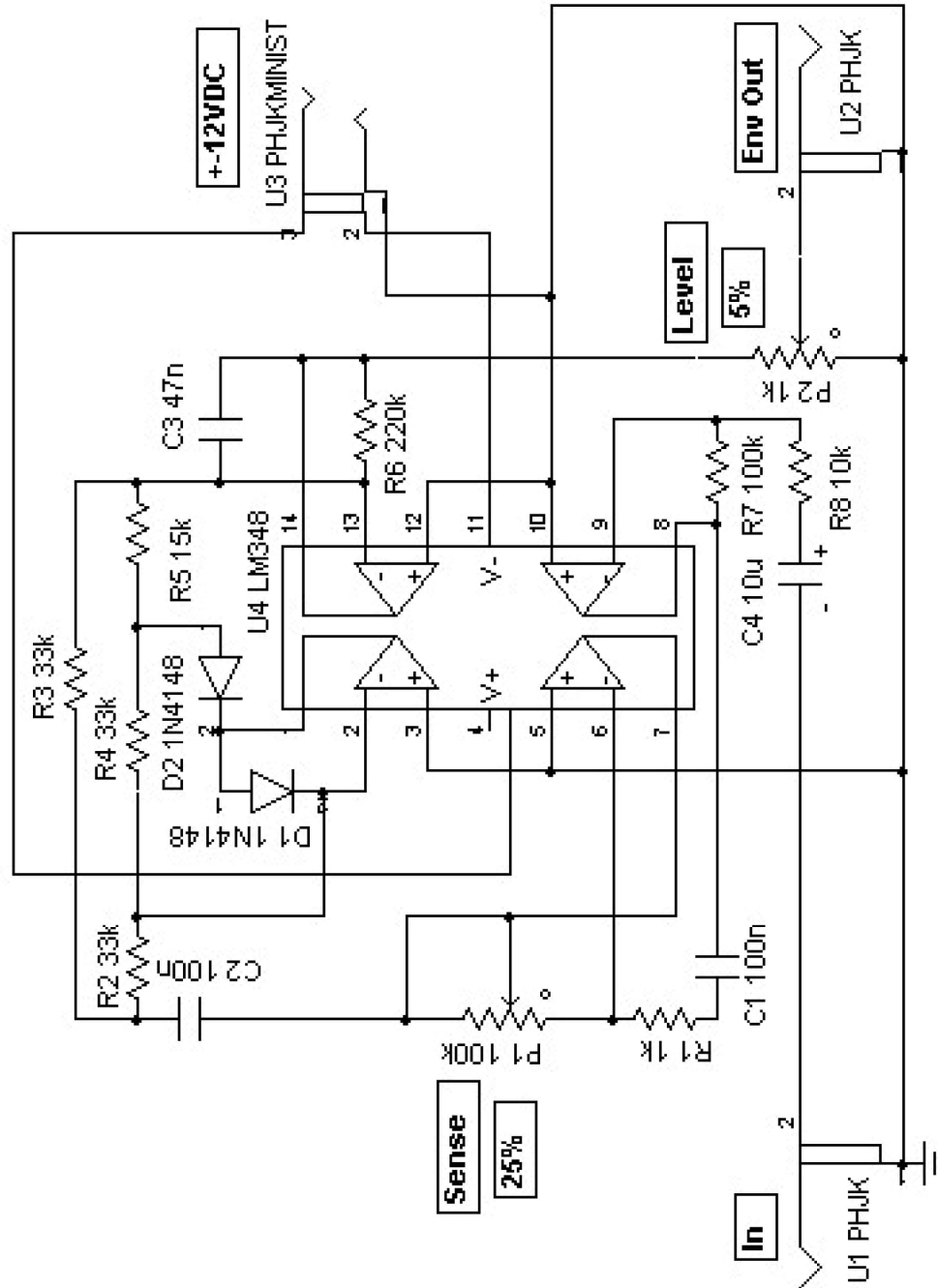

Envelope Follower 2

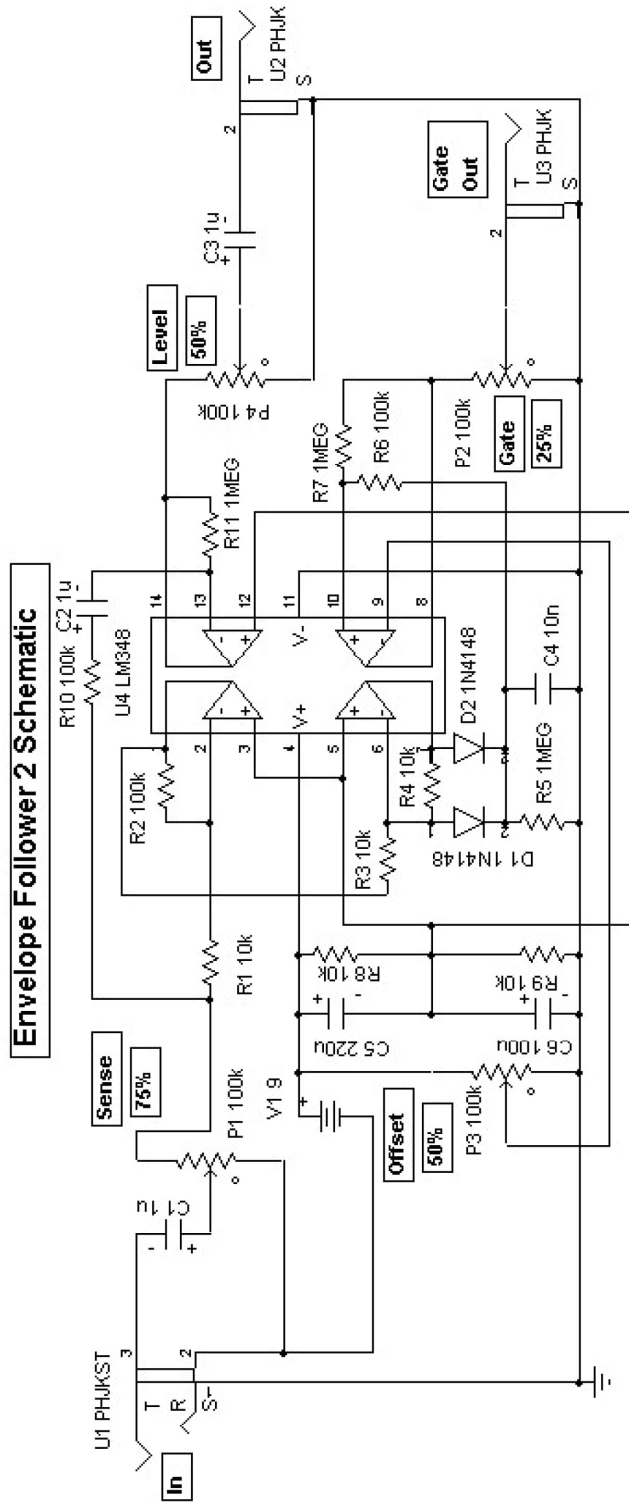

LED Audio Clip Detector

LED Audio Clip Detector Schematic

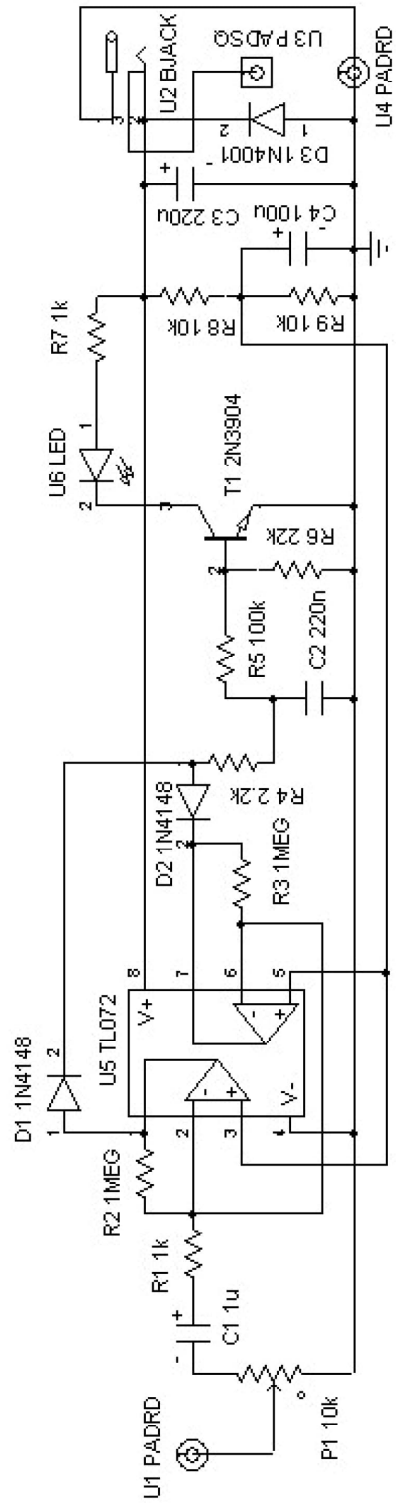

LED Peak Detector 1

LED Audio Peak Detector 1 Schematic

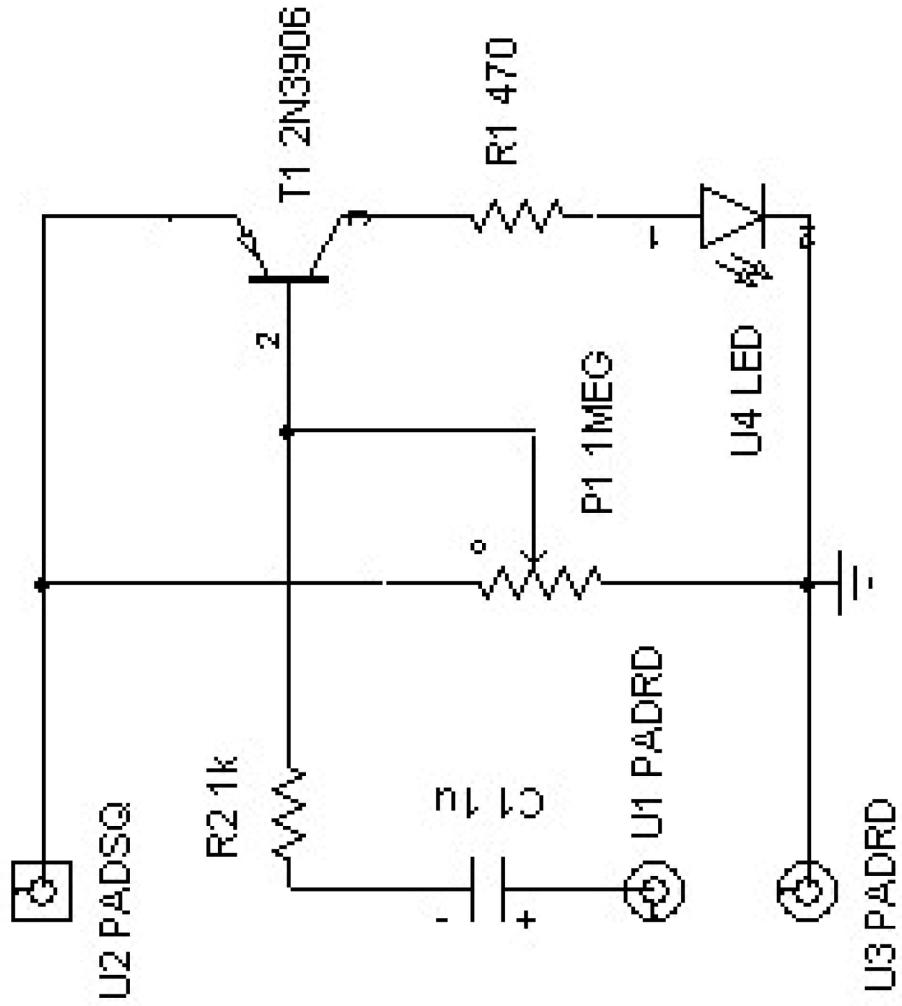

LED Peak Detector 2

LED Audio Peak Detector 2 Schematic

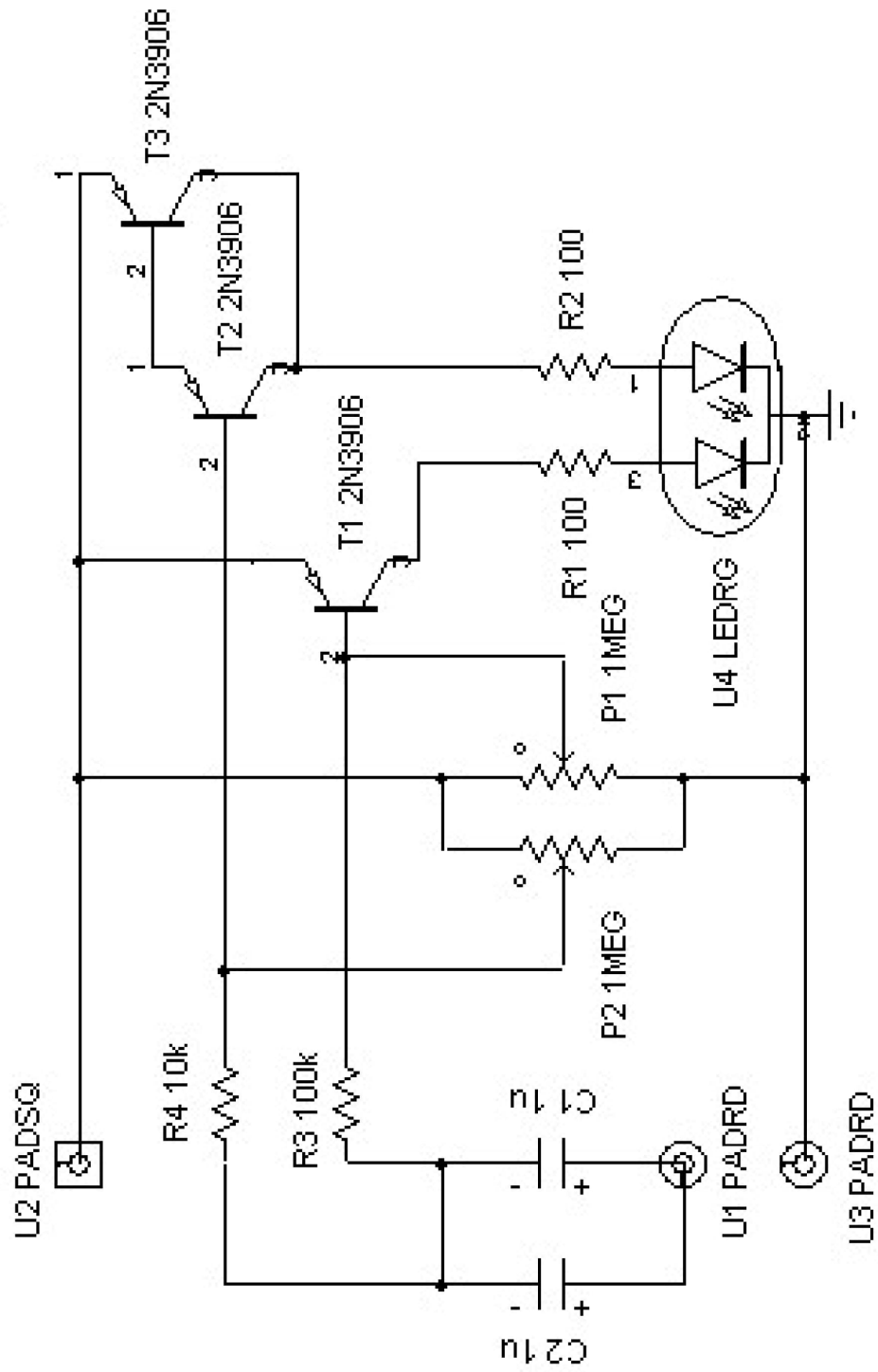

LED Peak Detector 3

LED Audio Peak Detector 3 Schematic

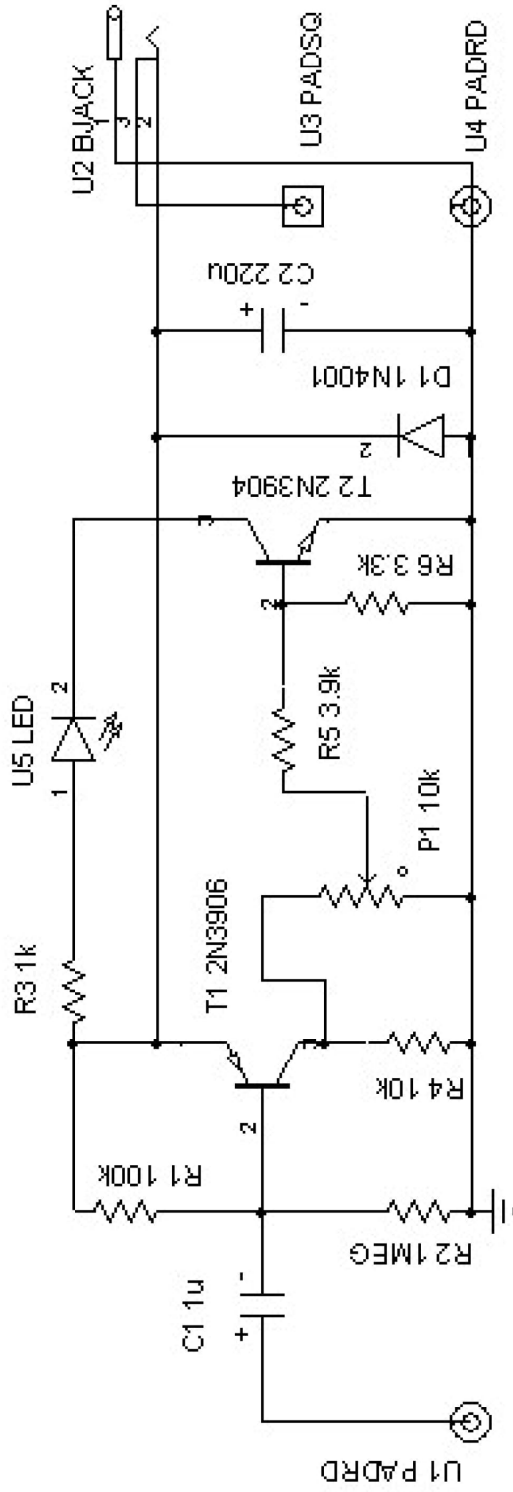

LED Peak Detector 4

LED Audio Peak Detector 4 Schematic

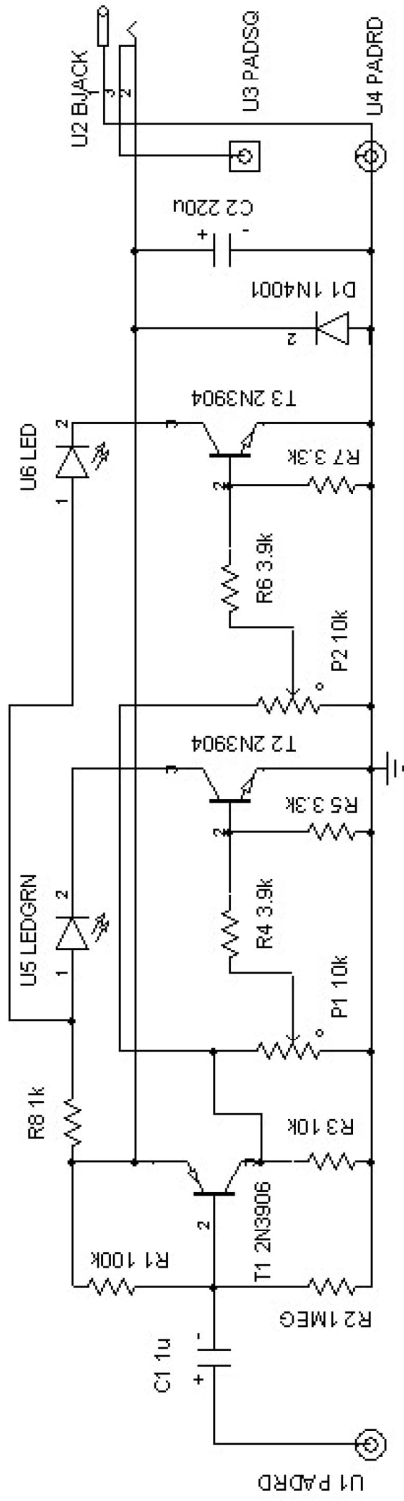

LM1458 1 Band Equalizer

LM1458 1 Band Equalizer Schematic

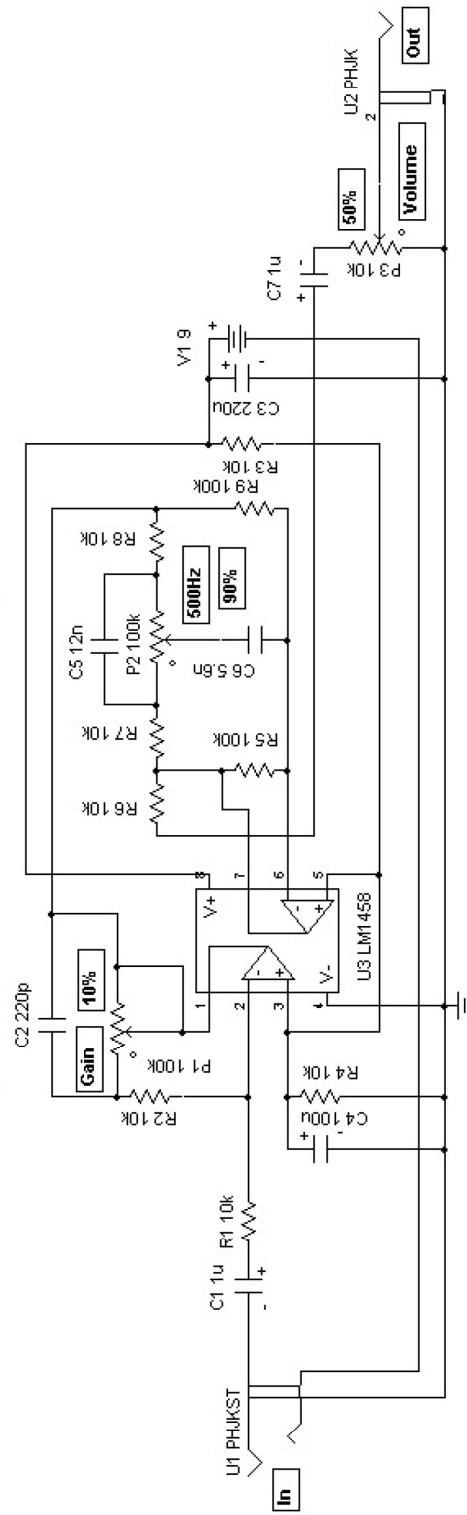

Quad OpAmp Voltage Controlled Amplifier 1

Quad OpAmp Voltage Controlled Amplifier 1 Schematic

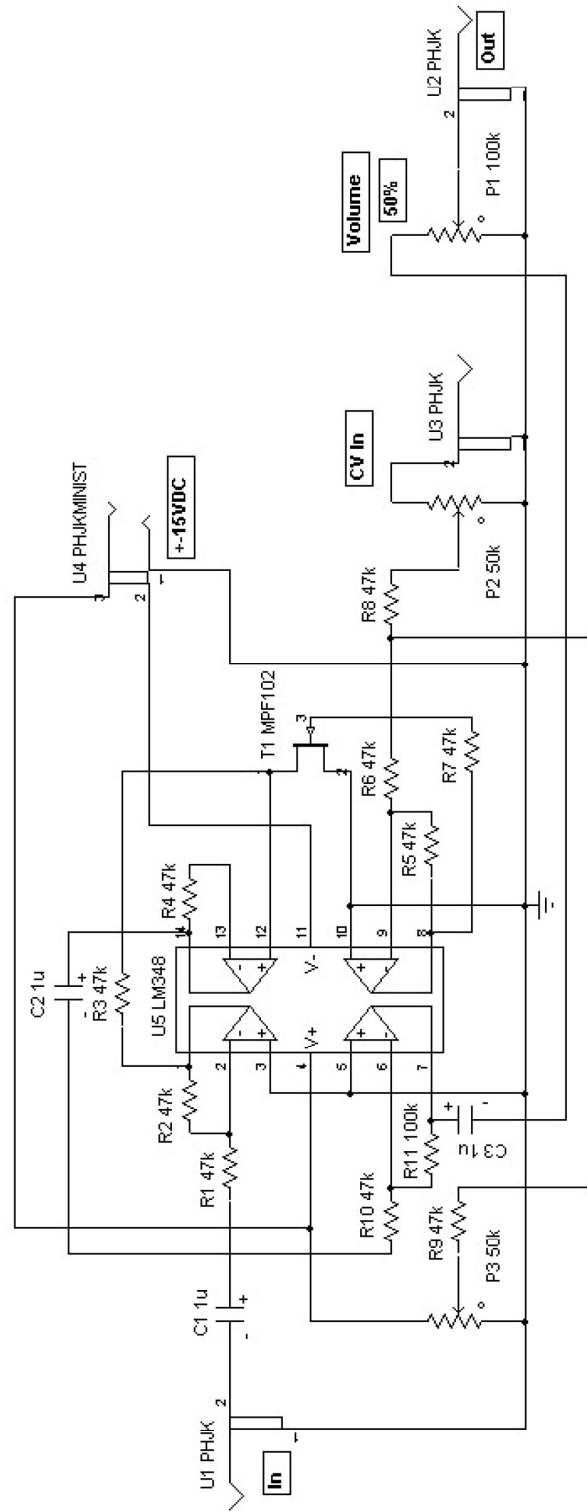

Quad OpAmp Voltage Controlled Amplifier 2

Quad OpAmp Voltage Controlled Amplifier 2 Schematic

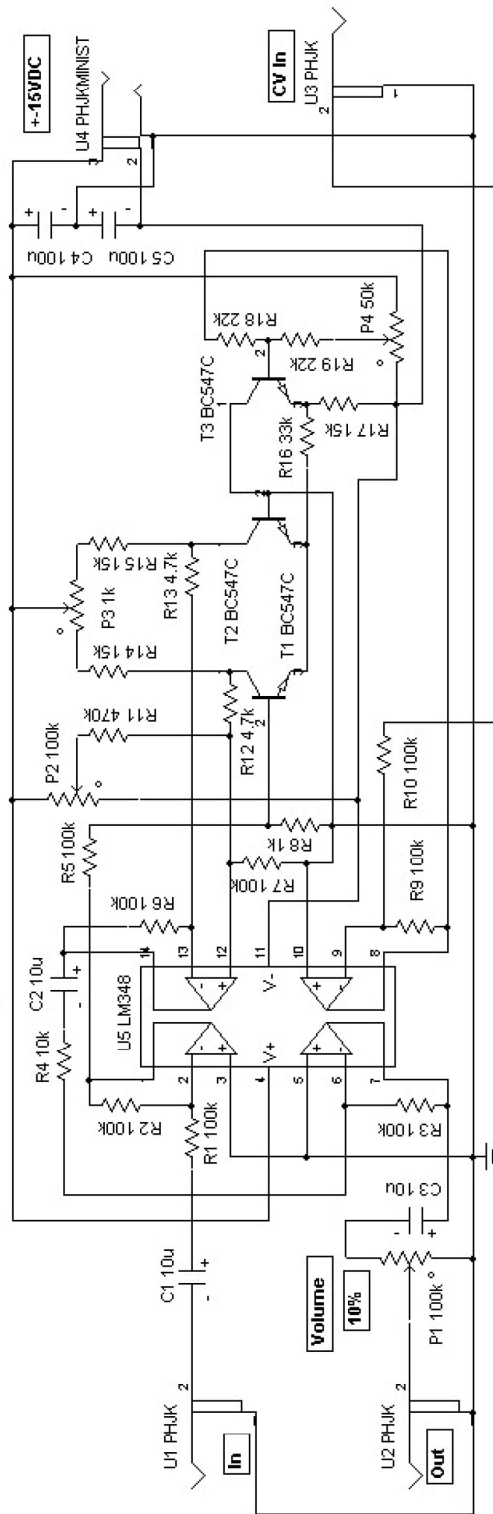

LM741 OpAmp Audio Preamp

LM741 OpAmp Audio Preamp Schematic

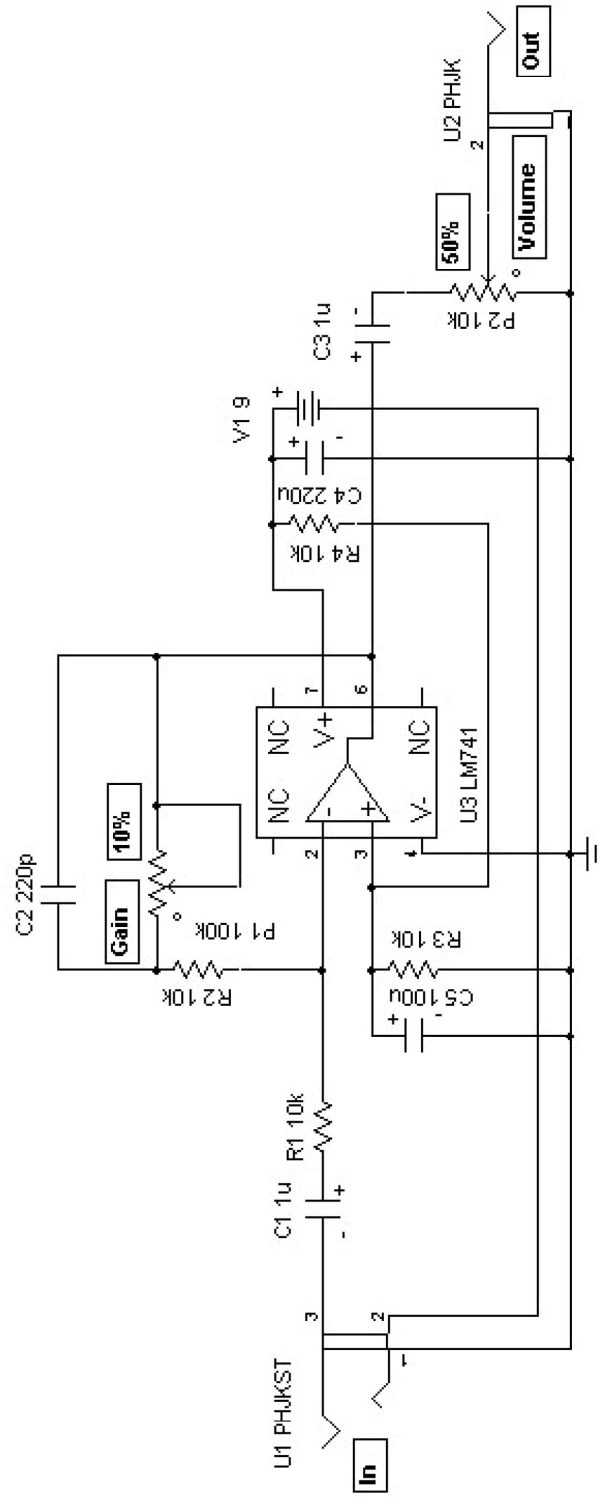

TL071 OpAmp Audio Preamp

TL071 OpAmp Audio Preamp Schematic

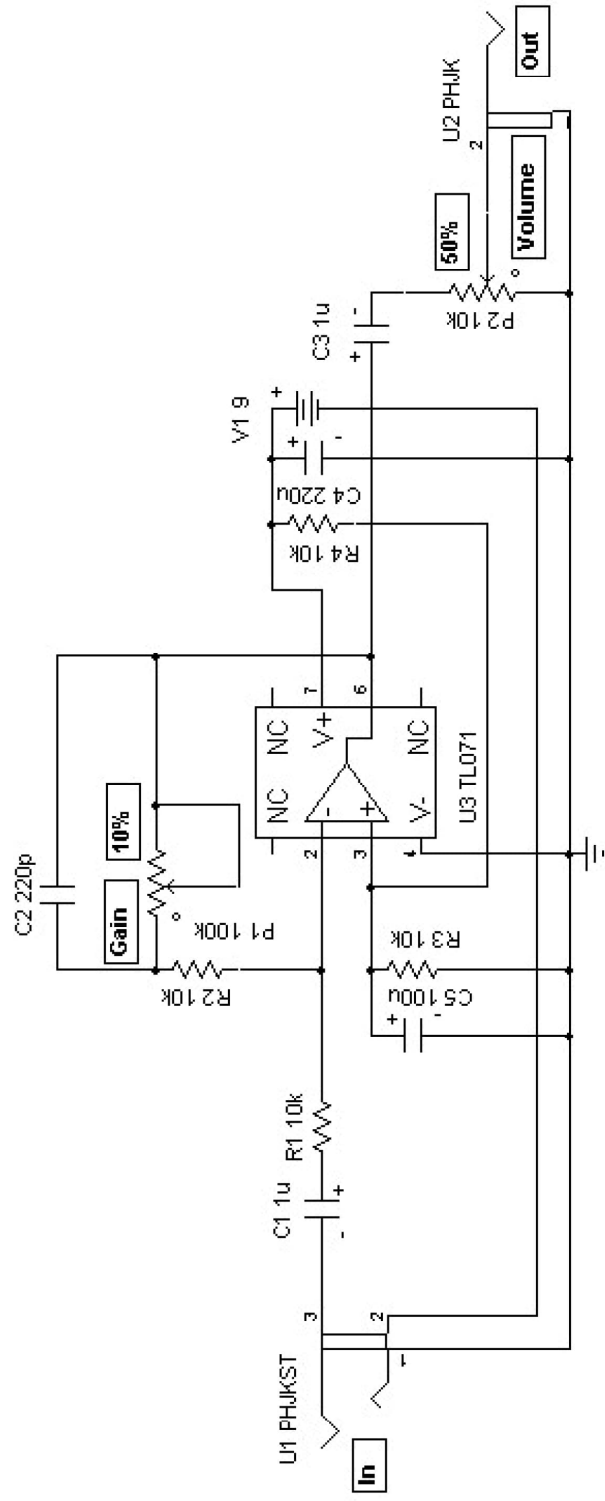

LM1458 Dual OpAmp Audio Preamp

LM1458 Dual OpAmp Audio Preamp Schematic

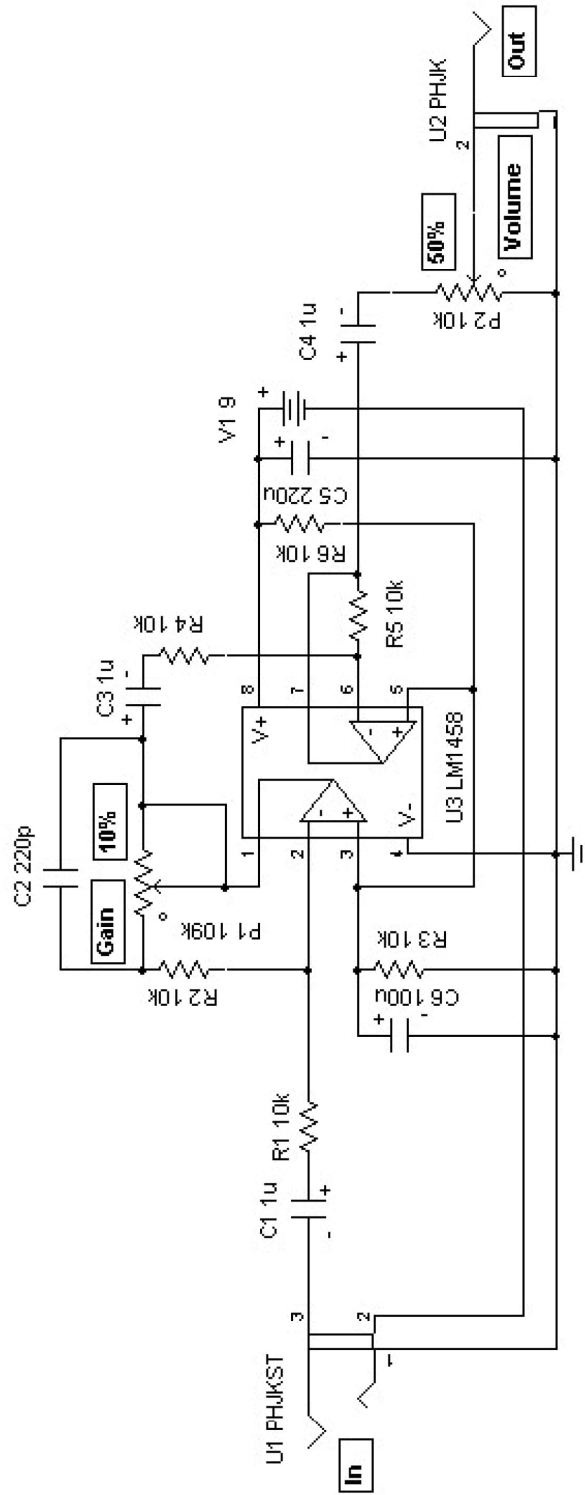

TL072 Dual OpAmp Audio Preamp

TL072 Dual OpAmp Audio Preamp Schematic

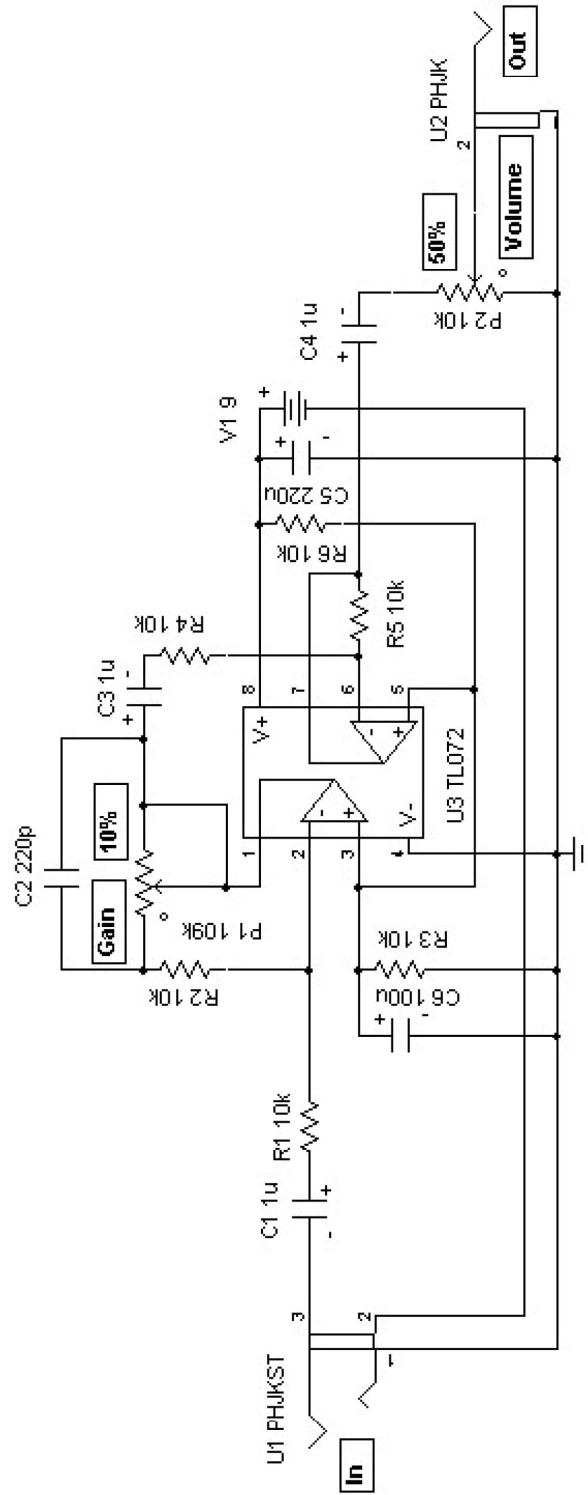

NSL-32 Optocoupler

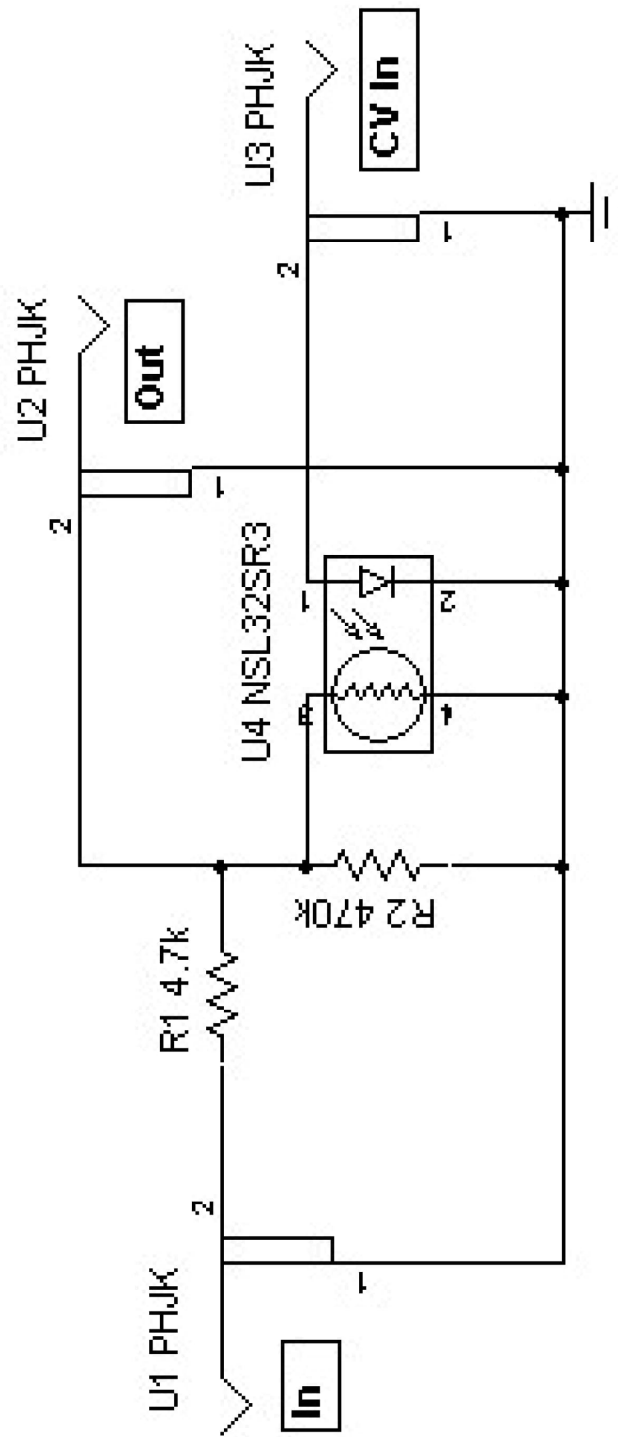

NSL-32 Optocoupler Volume Schematic

Voltage Controlled Amplifier 1

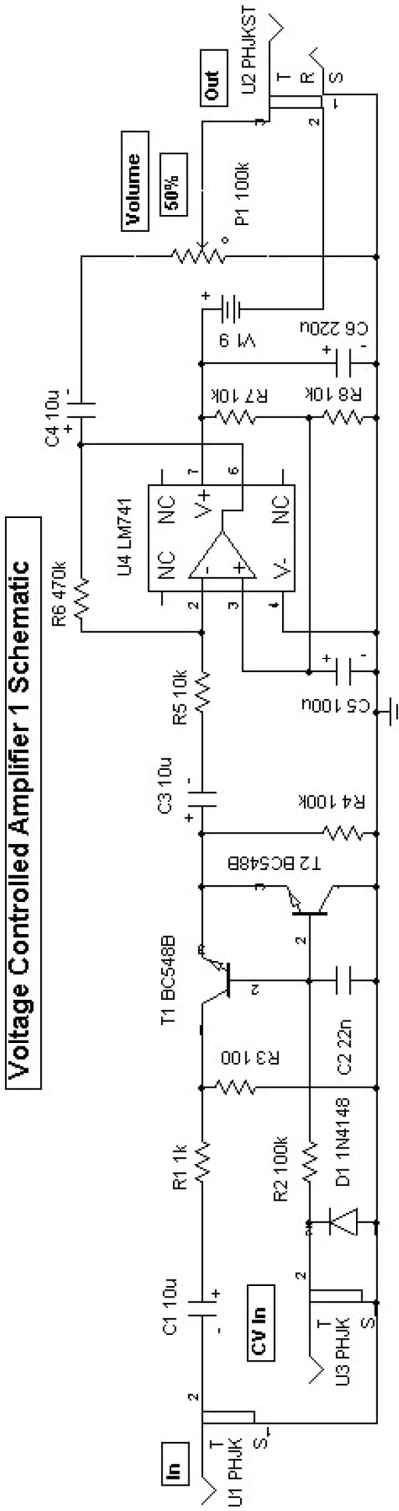

Transistor ADSR

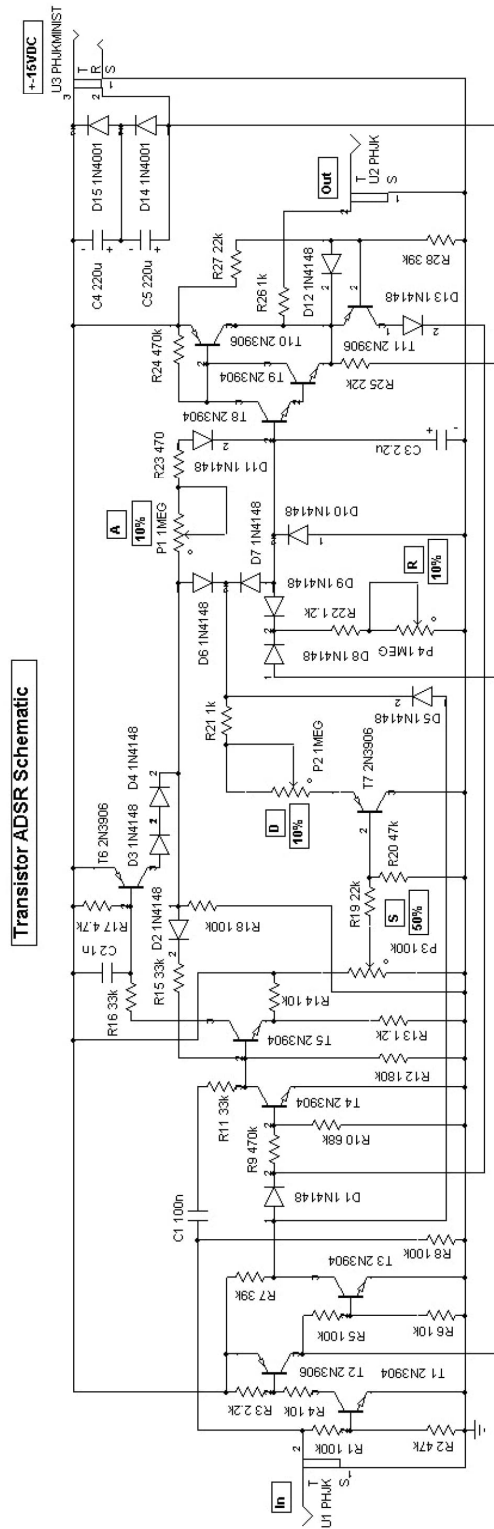

Transistor ADSR Schematic

Inventor eFX VSTs

Inventor eFX *Technology*

LLC

"Dedication to 'DIY'
Multimedia Technology"

All Exclusive Rights Respectively Reserved



The Invent eFXKit VSTi is Compatible as both a Recording Sound Effects VST or MIDI Input to Audio Output VSTi Playback Plugin Utilizing the MIDI SF2 Oscillator. It is a 'Virtual Effects' Processor with Multiple Sound Effects Plugins:

VCA & VCF ADSR Envelope Generator

'Virtual' Overdrive/Distortion/Fuzz

Phaser

Flanger/Chorus

Phaser/Oscillating Wah

Vibrato/Tremolo

Ring Modulator

Step Sequencer Frequency Filter

Reverb/Echo/Loop

AutoPan Stereo Rotating Speaker Simulator

8-Band Graphic Equalizer

It Includes the Following Features:

One of a Kind 'True Audio Input'

VCA (Voltage Controlled Amp) & VCF (Voltage Controlled Filter)

ADSR (Attack - Decay - Sustain - Release) Envelope Generator.

Virtual Overdrive/Distortion/Fuzz Effect with

3 Separately Adjustable Drives.

Frequency Modulation Effects for Varying Sound Tonality:

Flanger/Chorus

Phaser/Oscillating Wah

Tremolo/Vibrato.

Ring Modulator for Altering the Voicing of

Musical Instruments by Mixing 2 Frequencies (Note Pitches) Together.

Step Sequencer Frequency Filter Effect with Variable Pitch and Tempo.

Reverb/Echo/Loop Effect Capable of Producing

Subtle Reverb to Multiple Long Delay Echoes with 'Punch In/Out' Feature.

AutoPan Stereo Rotating Speaker Simulator with

Variable Rate and Mix Control.

8-Band Graphic Equalizer with Full Range Tone Control.

Each Effect has Its Own 'Digital True-Bypass' Switch.

Effects have 0-100% Mix or

Depth Control and Separate Output Volume Control.

Additional Signal Boost Switches for

Extremely Low-Level Input Signal Instruments.

A Multi-Function Effects Selector Button Column for

Ease of Choice of Any of the Connected Sound Effects ...

Both Single Effect and Multiple-Cascade-Chain Effects Capable.

A 'Midi-In ... to ... Audio-Out' Compatible SF2 Soundfont Oscillator for

Playing DAW MID Files to Audio Soundcard and Adding the Effects to the Playback.

Invent eFXKit

The screenshot displays the Invent eFXKit interface, which is organized into several functional sections:

- Master:** Includes controls for In Boost, Out, Mix, and Sync, with a Bypass button.
- 8-BandEQ eFX:** Features a frequency spectrum analyzer and sliders for Res, Boost, 50Hz, 100Hz, 250Hz, 500Hz, 1kHz, 2kHz, 4kHz, 8kHz, and Mix.
- EnvGen eFX:** Contains Sense, A, D, S, R, VCA, VCF, Res, Tone, Boost, and Mix controls.
- AutoPan eFX:** Includes Rate, Mix, Vol, Sync, and Bypass controls.
- VODrive eFX:** Features 1 Quad, 2 Dist, 3 Fuzz, Clip, and Vol controls.
- Phaser/OscWah eFX:** Includes Rate, Depth, Mix, Vol, Sync, and Bypass controls.
- ECycle eFX:** Contains Mode, Delay, Feedback, Mix, Vol, Punch, Sync, Echo, Loop, and Bypass controls.
- Flanger/Chorus eFX:** Includes Rate, Feedback, Depth, Mix, Vol, Sync, and Bypass controls.
- SeqFlir32 eFX:** Features Rate, Depth, Pitch, Mix, Vol, Sync, and Bypass controls.
- SFont2 eFX:** Includes Vol, Glide, and VoLO controls.
- Vibrolo eFX:** Contains Rate, Depth, Mix, Vol, Bypass, and Sync controls.
- RingMod eFX:** Includes Pitch, Mix, Vol, Bypass, and Sync controls.
- Wah:** Includes Res, Boost, 50Hz, 100Hz, 250Hz, 500Hz, 1kHz, 2kHz, 4kHz, 8kHz, and Mix controls.
- Filter:** Includes B-Pass, VCF, and VCA controls.
- Flanger/Chorus eFX (Secondary):** Includes Rate, Feedback, Depth, Mix, Vol, Sync, and Bypass controls.
- SeqFlir32 eFX (Secondary):** Includes Rate, Depth, Pitch, Mix, Vol, Sync, and Bypass controls.
- Vibrolo eFX (Secondary):** Includes Rate, Depth, Mix, Vol, Bypass, and Sync controls.
- RingMod eFX (Secondary):** Includes Pitch, Mix, Vol, Bypass, and Sync controls.

8-BandEQ eFX

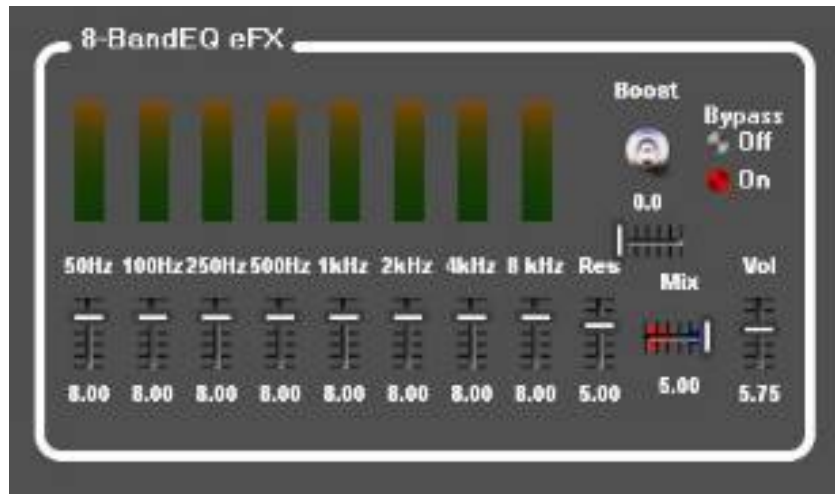

AutoPan eFX

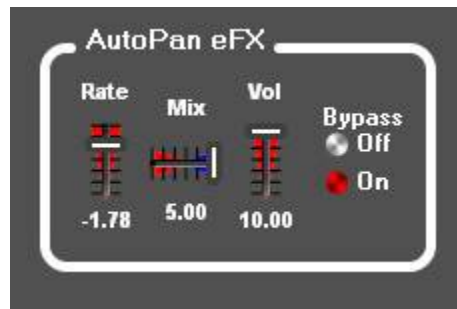

ECycle eFX



EnvGen eFX



Flanger/Chorus eFX

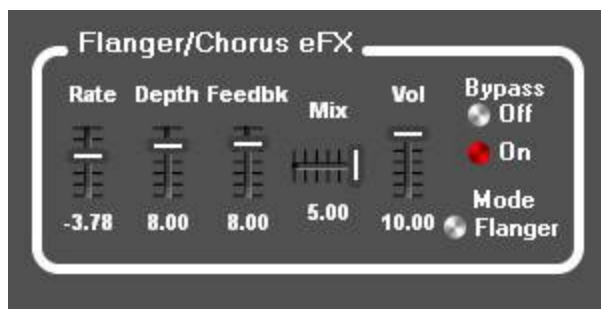

GuiTune eFX

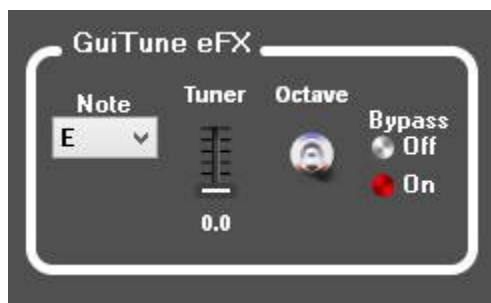

OscWah eFX



Phsr16/OscWah eFX

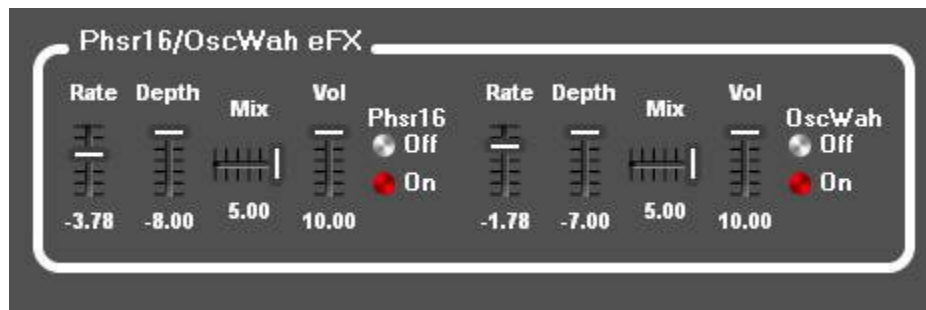

Phsr16 eFX

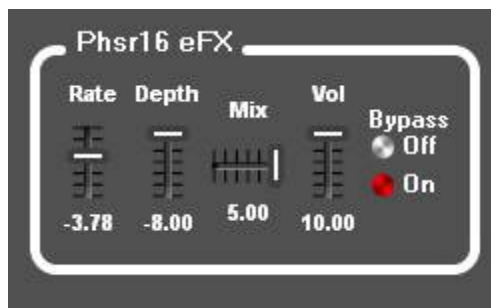

RingMod eFX



SeqFltr32 eFX

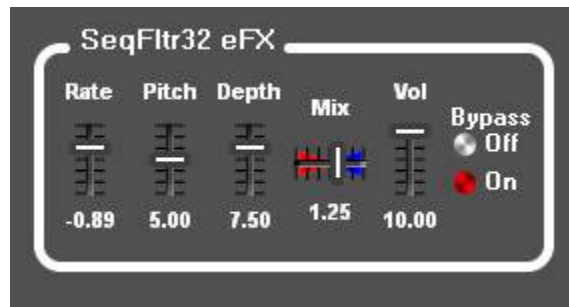

SFont2 eFX



Tremolo eFX



Vibrato eFX



Vibrolo eFX

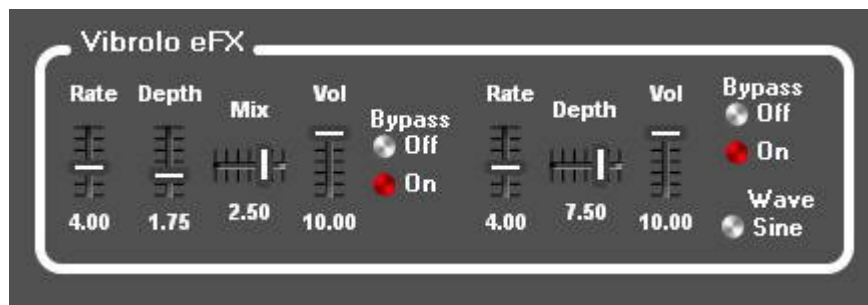

VODrive eFX

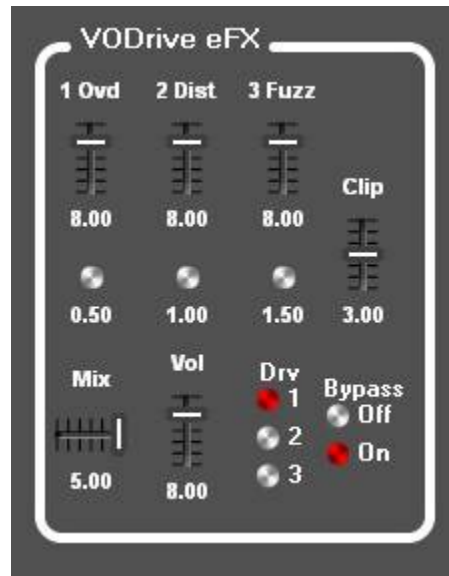

Inventor eFX Technology Digital Audio Effects/Instruments FlowStone VST/VSTi Plugins & Standalone Executables

Genuine Steinberg Authorized Developer of
'Virtual Studio Technology'
(VST2 & VST3) Modular Computer Plugins.



Designed with FlowStone Version 3.0.6 (Pebble)
VST/VSTi Export with FlowStone Version 3.0.9 Beta 3 (x64)



FlowStone Software + Ruby Code = FlowStone Project

VST & VSTi Sound Effects Plugins for Use with
Compatible Microsoft Windows DAWs
(Digital Audio Work Stations)

Tested On:

Bremmers MultitrackStudio Pro

FL Studio 20

Steinberg Cubase LE AI Elements

MAGIX Sound Forge Pro

Ableton Live

Etcetera ...

Compozatron

Compozatron VSTi ID: 51

Compozatron Deluxe

Compozatron Deluxe VSTi ID: lgy-

eFXatron

Audio In: None | Audio Out: None | SmpI Rate: 44100 | ASIO Settings...

Off eFX | MSTR IN x1 | eFXatron | VST ID: zA=Y | MSTR OUT

ST | Clear Audio | BPM 120 | UnLok ReName>Preset 1 | File 32 | 1/32 | Inventor eFX Flow Stone

OctDrive

Octz | Off x1 | Ovd Vol | Oct Mix | Dist Vol | 0.00

Flanger

Ratio Off | x1/2 | 16 | Rate Mix | Pwr On | Fdbk Vol | BPM Sync

Reverb

Off | Width Mix | Room Vol

Echo

Ratio x1 | 1s | Delay Mix | Fdbk Vol

Tremolo

Off | Sine | Ratio x8 | BPM Sync On | Rate Mix Vol

OscWah

Moog Off | Cut Res Vol | Wave Ratio | Sine x1/2 | Rate Mix BPM Sync On

VCF

Auto Trig | Off | A R Amt | Moog | Cut Res Vol

SyncXPan

Off | Ratio x1/2 | Sine | Rate Mix Vol | BPM Sync On

30	60	120	250	500	750	1500	3000	6000	12000	L	R	Res
5.0	5.0	5.0	5.0	5.0	5.0	5.0	5.0	5.0	5.0	6.3	0.50	

VU 5.0

Eq10MPXefx

Audio In: None | Audio Out: None | Smpl Rate: 44100 | ASIO: ASIO Settings...

Off eFX | UnLok Name> Preset 1 | File 32 < 1/32 > | VST ID: q0'' | MSTR

ST

30 60 120 250 500 750 1500 3000 6000 12000 L R Res

5.0 5.0 5.0 5.0 5.0 5.0 5.0 5.0 5.0 5.0 6.3 0.50

0.1 Fine | Off

Off | Gain 1.00 | Time x2

MPeFXatron

The interface features a top section for audio routing with 'Audio In' and 'Audio Out' set to 'None', 'Smpl Rate' at 44100, and 'ASIO Settings...' button. Below this, 'MSTR IN' and 'MSTR OUT' are connected. The main title 'MPeFXatron' is centered, with 'VST ID: A^rJ' to its right. A 'Clear Audio' button and a BPM control (set to 120) are on the left. A central control bar includes 'On/Off', 'ReName>Preset 1', and a 'File' dropdown set to 32.

The interface is divided into several effect modules:

- OctDrive:** Includes 'Octz' control, 'Off' dropdown, and 'x1' multiplier. Parameters include 'Ovd', 'Vol', 'Oct', 'Dist', and 'Mix'.
- Flanger:** Features 'Ratio' (x1/2), '16' dropdown, 'Pwr' knob, and 'On' button. Parameters include 'Rate', 'Mix', 'Fdbk', and 'Vol'.
- Reverb:** Includes 'Off' button, 'Width', 'Mix', and 'Room Vol' controls.
- Echo:** Features '1s' dropdown, 'Ratio' (x1), 'Delay', 'Mix', and 'Fdbk' controls.
- Tremolo:** Includes 'Sine' dropdown, 'On' button, 'Ratio' (x8), and 'BPM Sync' controls.
- OscWah:** Features 'Moog' dropdown, 'Off' button, and 'Cut', 'Res', 'Vol' controls.
- SyncXPan:** Includes 'Off' button, 'Ratio' (x1/2), 'Sine' dropdown, and 'On' button. Parameters include 'Rate', 'Mix', 'Vol', and 'BPM Sync'.
- VCF:** Features 'Auto', 'Trig', 'A', 'R', and 'Amt' controls.
- Moog:** Includes 'Moog' dropdown and 'Cut', 'Res', 'Vol' controls.

A frequency spectrum analyzer is located in the lower right, showing frequency ranges from 30 to 12000 Hz, with 'L', 'R', and 'Res' channels. Below the analyzer, a 'Gain' control is set to 1.00, and a 'Time' control is set to x2. A 'Fine' control is set to 0.1. The bottom section contains a horizontal timeline with several colored markers (yellow, red, green).

Padzatron

The interface is divided into several functional sections:

- Top Bar:** Audio In (None), Audio Out (None), SmpI Rate (44100), and ASIO Settings... button.
- MIDI Section:** MIDI In Ext (None), MIDI In (Int), MIDI Thru (On), MIDI Out (Int), and MIDI Out Ext (None).
- Frequency Response:** A series of sliders for frequencies: 30, 60, 120, 250, 500, 750, 1500, 3000, 6000, and 12000 Hz. Includes a 10 VU meter and Res (0.50) control.
- Effects Section:** Includes Flanger (Ratio: x1/2, 16), Reverb (Off), Echo (Ratio: x1, 1s), and SyncXPan (Ratio: x1/2, Sine). Each effect has its own set of sliders for parameters like Rate, Mix, Delay, and Fdbk.
- Audio Section:** Audio In (Off), eFX (Off), and ST (dropdown).
- MIDI Map Section:** A grid of buttons for MIDI notes: 59 (Play), 67 (Play), 75 (Play), 88 (Run), 27 (Play), 35 (Play), 43 (Play), and 51 (Play). Each button is associated with a GM MIDI Map name like "Ride Cymb1 2", "Hi Agogo", "Claves", "Hi Q", "Acous B Drum", "Hi Fir Tom", and "Ride Cymb1 1".
- Bottom Right:** A "Clear Audio" button, a file loader for "kngmelecst2.sfz" (Load... Clear), and an SFZ section with Octv (0) and Semi (0) controls.

Padzatron Deluxe

Audio In: None | Audio Out: None | SmpI Rate: 44100 | ASIO Settings...

File: 32 < 1/32 > | MIDI In Ext: None | MIDI In: Int | MIDI Thru: On | MIDI Out: Int | MIDI Out Ext: None

Audio In: Off | Vol: [Slider] | eFX: Off | Res: Off | x1

30 60 120 250 500 750 1500 3000 6000 12000 | 10 VU | 6.3 | 0.50

ST | Flanger Ratio: Off | Reverb: Off | Echo Ratio: Off | SyncXPan: Off

Guitar: Note On | Pitch Bend | Rate Mix Pwr | Width Mix | Delay Mix | Sine | Rate Mix Vol

Guitar MIDI In: Off | Fdbk Vol Sync | Room Vol | Fdbk Vol | BPM Sync | BPM Sync

MIDI # 59 Play | GM MIDI Map Ride Cymb1 2 | MIDI # 67 Play | GM MIDI Map Hi Agogo | MIDI # 75 Play | GM MIDI Map Claves | NOTE# 88 Stop | Clear Audio

120 BPM | MIDI # 27 Play | GM MIDI Map Hi Q | MIDI # 35 Play | GM MIDI Map Acous B Drum | MIDI # 43 Play | GM MIDI Map Hi Fir Tom | MIDI # 51 Play | GM MIDI Map Ride Cymb1 1

4000 mSec | kngmelecst2.sfz | Load... | Clear

Octv: 0 | Semi: 0 | SFZ

Inventor cFX Flow Stone

Padzatron DLX

Scopetron

None Primary Sound Driver ASIO Settings... 44100

Oscopse

Gain: 1, 0.8, 0.6, 0.4, 0.2, 0

x32

Time Rate: x32 Samples



Fast Fourier Transform

Auto Flat Top 1024 90dB

Refresh

Ext Input

Sens: 60 Hz, 150 Hz, 350 Hz, 750 Hz, 1500 Hz, 3000 Hz, 6000 Hz, 11000 Hz

Vol: 5.0

Q: 2.0

Sine Freq: 440 Hz

Sens	60 Hz	150 Hz	350 Hz	750 Hz	1500 Hz	3000 Hz	6000 Hz	11000 Hz
dB	9.9	7.2	5.2	4.0	7.9	5.2	7.3	2.7

On

SeqArpeggiator

The interface is divided into several functional sections:

- Audio Section:** Includes 'Audio In' (None), 'Audio Out' (Primary Sound Driver), 'ASIO' settings, 'ASIO Set...', 'Smpl Rate' (44100), 'TimeSig' (1/1, 4/4), 'Clear Audio', and 'Audio' output.
- MIDI Section:** Features 'MIDI In Ext' (None), 'MIDI Out Ext' (None), 'MIDI In' (Int), 'MIDI Thru' (On), and 'MIDI Out' (Int). It also includes 'Ratio' (x1), 'SyncXPan' (Sine, On), and 'Rate', 'Mix', 'Vol' sliders.
- Sequencer Section:** Contains 'Random' (On), 'BPM' (120), 'Span' (4), 'Semi' (12), and 'Octave Semi' (0, 0). It has 'Square' wave type, 'Fine Vol', and 'Sync' (On) controls.
- Grid Section:** A 16x16 grid for sequencing notes. Includes 'On' (green) and 'Time Sync' (grey) buttons, 'Time Sig' (4/4), 'Note' (1/8), 'Semi' (1), 'BPM Sync' (On), 'Steps Gate' (16), and a 'Peak' dropdown.
- Envelope Section:** Controls for 'Saw' wave, 'Octave Semi' (0, 0), 'Fine', 'Vol', and envelope stages 'A', 'D', 'S', 'R', 'Cut', 'Res', 'Trk'.
- Sample Section:** Shows '<no sample loaded>', 'Load...', 'Clear', 'Octv' (0), 'Semi' (0), 'On' (red), and 'SFZ', 'A', 'D', 'S', 'R', 'Vol' controls.

SFZefxatron

Audio In: None | Audio Out: None | SmpL Rate: 44100 | ASIO: ASIO Settings...

MIDI In Ext: None | MIDI In: Int | MIDI Thru: On | MIDI Out: Int | MIDI Out Ext: None

ReName> Preset 1 | File 32 < 1/32 > | VSTi ID: (#m+)

SFZeFXatron

OctDrive **eFX** ST **MSTR IN** x1 **MSTR OUT** **OscWah** Moog

Flanger Ratio: x1/2 | **Reverb** Ratio: 16 | **Echo** 1s | **Tremolo** Ratio: x8

Reverb Width: | **Echo** Delay: | **Tremolo** Sine | **OscWah** Moog

Auto VCF **SyncXPan** Ratio: x1/2

Auto VCF A: | **SyncXPan** Rate: | **Auto VCF** R: | **SyncXPan** Mix: | **Auto VCF** Amt: | **SyncXPan** Vol: | **Auto VCF** Cut: | **SyncXPan** Res: | **Auto VCF** Res: | **SyncXPan** BPM Sync:

Inventor cFX Flow Stone | 1 Grand Piano F4.sf | **Load...** **Clear** | **VCA** BPM: 120

Clear Audio | **Octv** 0 **Semi** 0 | **Vibro** Sine | **Vibro** Rate: | **Vibro** Amt: | **Vibro** Cut: | **Vibro** Res: | **Vibro** Vol: | **Vibro** BPM Sync: x8 | **Vibro** PBnd:



0 OFF CLR

SFZMXeFX

Audio In: None
Audio Out: None
Smpl Rate: 44100
ASIO: ASIO Settings...

MIDI In Ext: None
MIDI In: Int
MIDI Thru: On
MIDI Out: Int
MIDI Out Ext: None

File: 32 < 1/32 >
VSTi ID: KX?

SFZMXeFX

OctDrive: Off
Octz
Ovd Vol
Dist Vol
0.00

eFX: Off
ST
MSTR IN x1
MSTR OUT

Flanger: Off
Ratio: x1/2
16
Rate Mix
Fdbk Vol
Pwr
BPM Sync

Reverb: Off
1s
Ratio: x1
Delay Mix
Fdbk Vol
Room Vol

Echo: Off
Ratio: x1
Delay Mix
Fdbk Vol
BPM Sync

Tremolo: Off
Sine
BPM Sync: On
Rate Mix Vol

OscWah: Off
Moog
Cut Res Vol
Wave Ratio
Sine x1/2
Rate Mix BPM Sync

VCF: Off
Auto Trig
A R Amt
Moog
Cut Res Vol

SyncXPan: Off
Ratio: Sine x1/2
Rate Mix Vol
BPM Sync

Piano Roll:
30 60 120 250 500 750 1500 3000 6000 12000 L R Res
5.0 5.0 5.0 5.0 5.0 5.0 5.0 5.0 5.0 5.0 5.0 6.3 0.50

Inventor eFX Flow Stone
1 Grand Piano F4.sf
Load... Clear

VCA: 0.00
Cut Res Vol
BPM Sync: x8

Other Controls:
Clear Audio
Octv: 0
Semi: 0
Vibro SFZ: Off
Sine
Rate Amt
PBnd: Off

SFZVibefFX

The interface is divided into several functional sections:

- MIDI Routing:** Located at the top, it features dropdown menus for MIDI In Ext (None), MIDI In (None), MIDI Thru (None), MIDI Out (44100), and MIDI Out Ext (None). A central MIDI chain shows 'Int' (Intercept) and 'On' (On) buttons with arrows indicating signal flow.
- Preset Management:** A box on the left contains 'UnLok', 'ReName> Preset 1', and 'File 128 < 1/128 >' with navigation arrows.
- File Information:** Below the preset box, it shows '1 Grand Piano F4.sf' and buttons for 'Load...' and 'Clear'.
- Parameters:** A central area contains various controls: 'Octv' (0) and 'Semi' (0) dropdowns; 'Vibro SFZ' (Off) and 'Sine' (dropdown) buttons; 'Rate' and 'Amt' sliders; 'Pan' (0.00) and 'VCA' (dropdown) controls; 'Cut', 'Res', and 'Vol' sliders; 'BPM Sync' (x8 dropdown) and 'PBnd' (Off) buttons.
- Visual Feedback:** A 'BPM 120' display and a '0' indicator are shown in a box on the right.
- Keyboard:** A piano keyboard graphic is at the bottom, with a 'CLR' (Clear) button highlighted in red.

Tunetron

The interface is divided into several sections:

- Audio In:** A dropdown menu set to "None".
- Audio Out:** A dropdown menu set to "None".
- Smpl Rate:** A dropdown menu set to "44100".
- ASIO:** A button labeled "ASIO Settings...".
- Oscillator Section:** Includes an "In" icon, a black "Osc" button, a "Saw" dropdown, a "Key" dropdown, a MIDI # display showing "60", a red "Inst" button, and an "Osc" icon.
- Instrument Section:** A row of six black buttons labeled "E", "A", "D", "G", "B", and "E". To the right is a black "Guit" button with "40" below it.
- Tuner Section:** Features "Input Pitch" and "Tuner Pitch" displays, both showing "-3" and "0.00 Hz". Between them are "LO" and "HI" buttons and a green "CTR" button with a note icon. A blue "On" button is also present.
- Footer:** The text "Inventor eFX Flow Stone" is displayed in the bottom right corner.

Inventor eFX Technology



VST Plug-In Technology
by Steinberg
Licensing by Steinberg Technology
VST is a trademark of
Steinberg Media Technologies GmbH



Logo by Steinberg Technology

**... Supplemental ...
The Author Paul William Engholm
is a Retired
Composer/Songwriter/Musician
and Audio Electro-Physicist and an Inventor.**



The Author Paul William Engholm
is a Retired
Composer/Songwriter/Musician
and Audio Electro-Physicist and an Inventor.

